



© Skyshots; modified by The First Church of Christ, Scientist

CHRISTIAN SCIENCE PLAZA REVITALIZATION PROJECT

Dalton Site Proposal

CAC 10 11.12.09

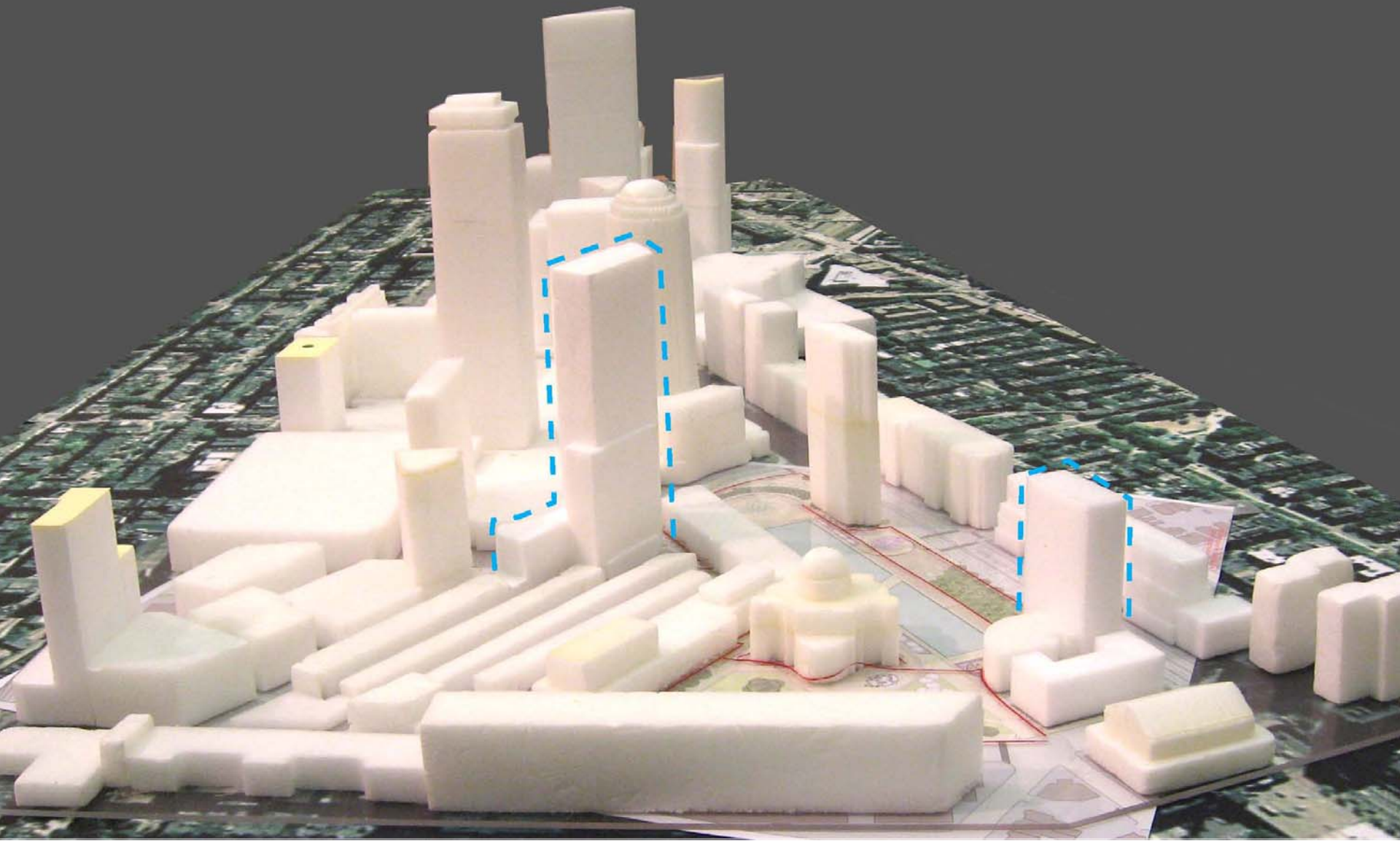

Courtesy of The First Church of Christ, Scientist

PREVIOUS PROPOSAL : Context Model View - - - - -

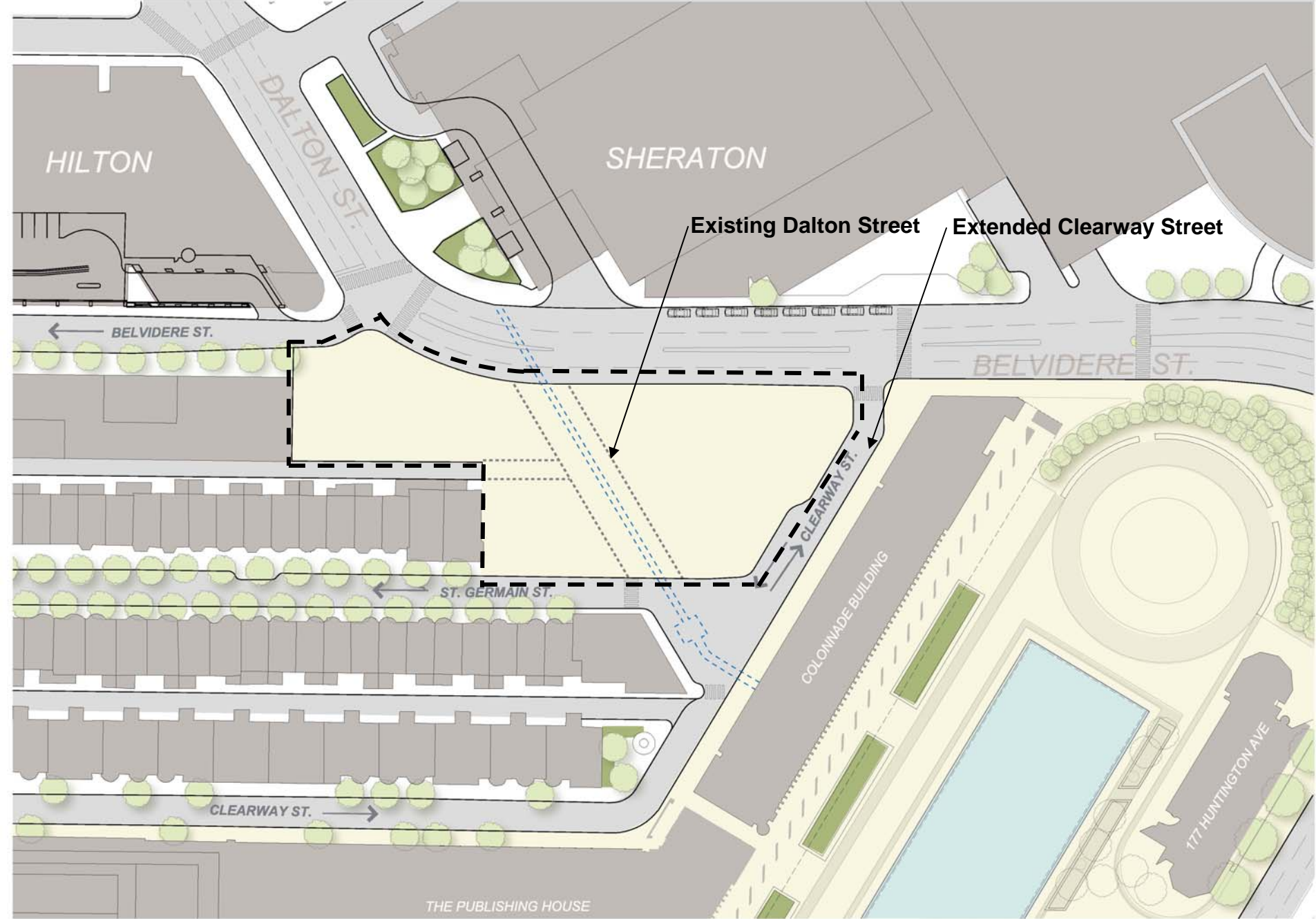

Courtesy of The First Church of Christ, Scientist

PROPOSED RECONFIGURATION OF DALTON SITE

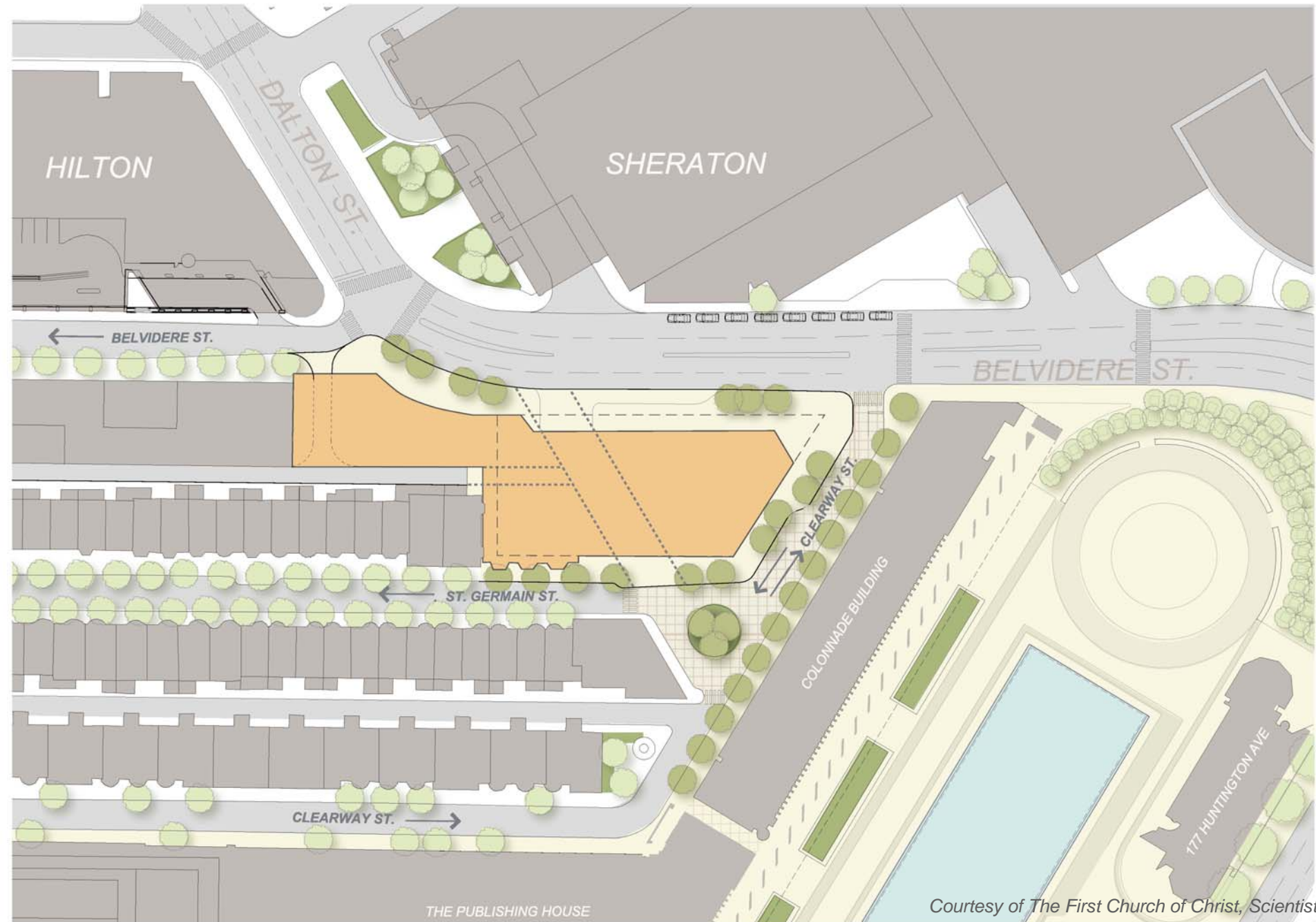

DALTON SITE : Previous Proposal Building Footprint

Courtesy of The First Church of Christ, Scientist

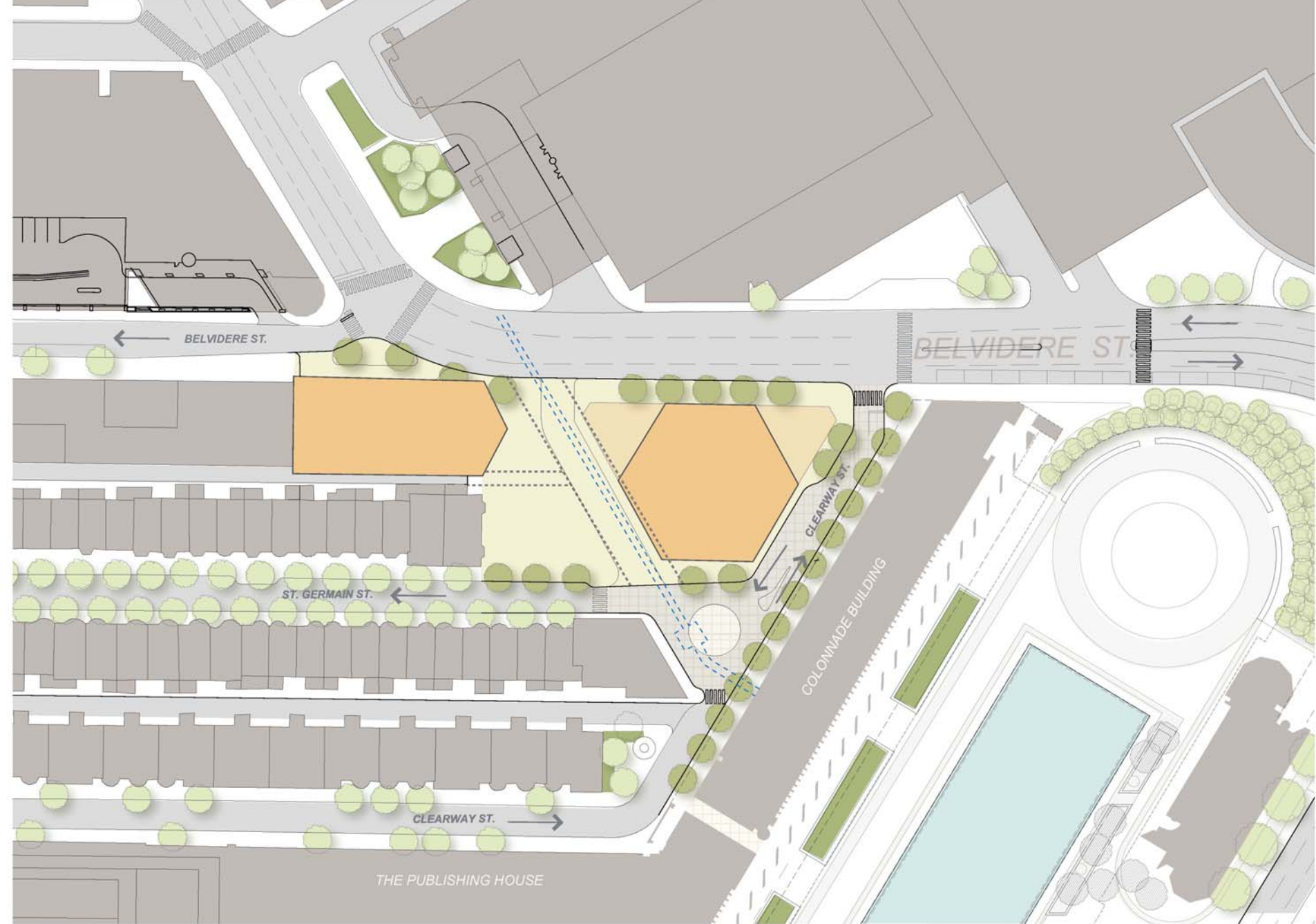

Courtesy of The First Church of Christ, Scientist

DALTON SITE : Current Proposal Building Footprints

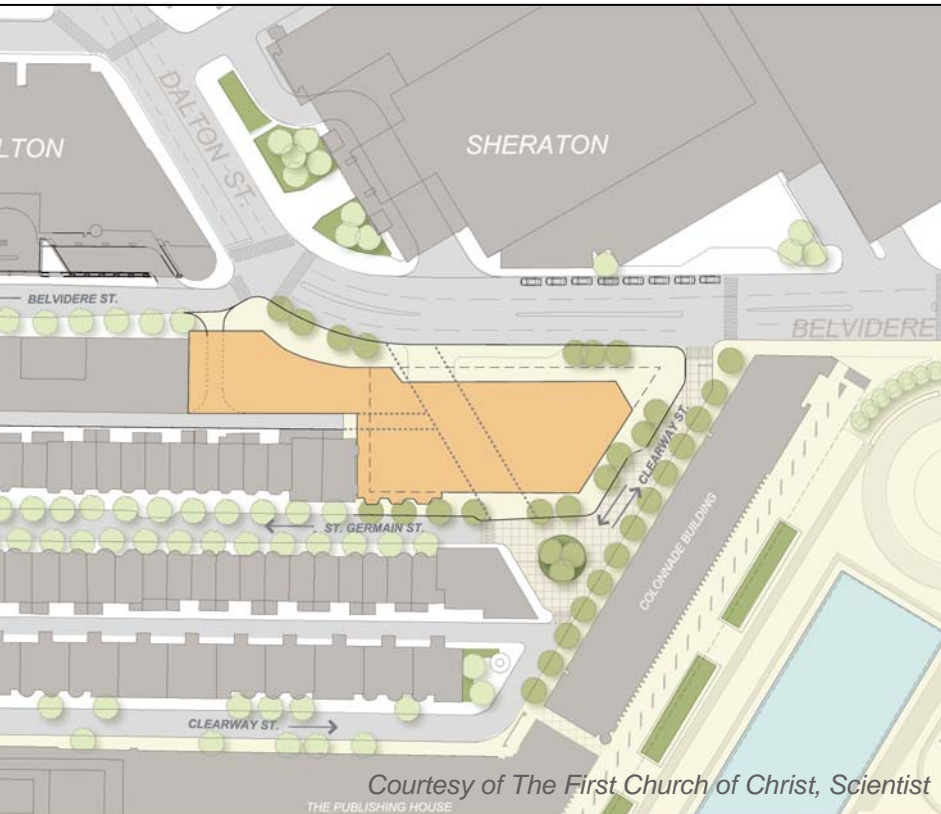

PREVIOUS PROPOSAL

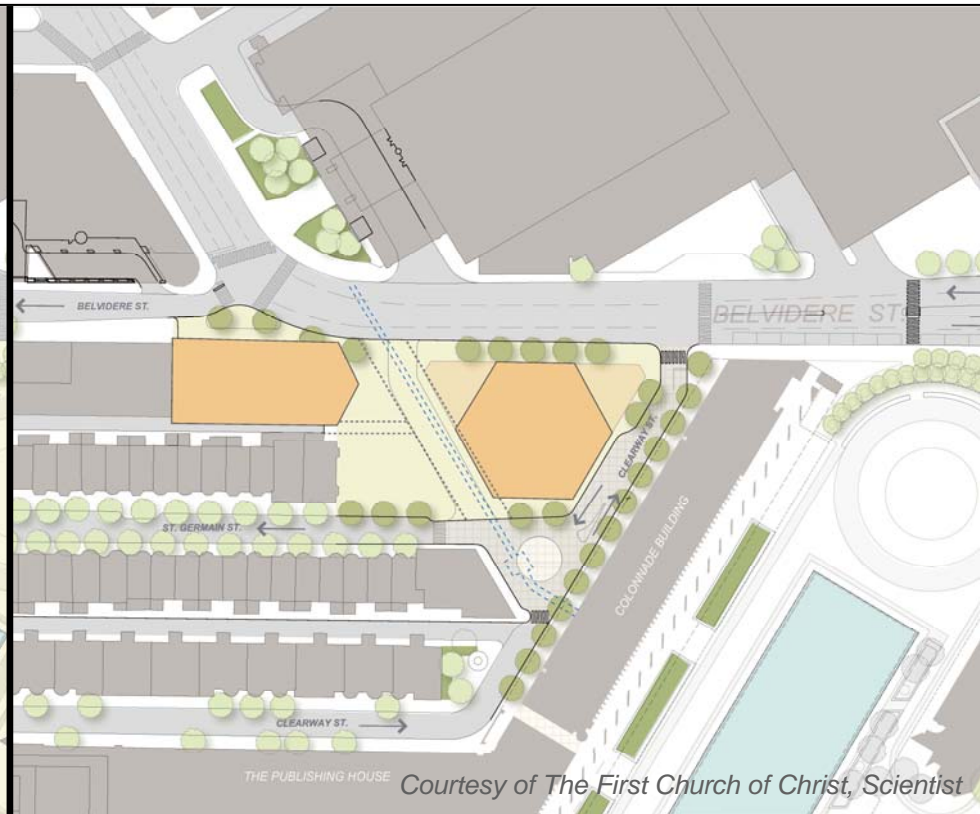

CURRENT PROPOSAL

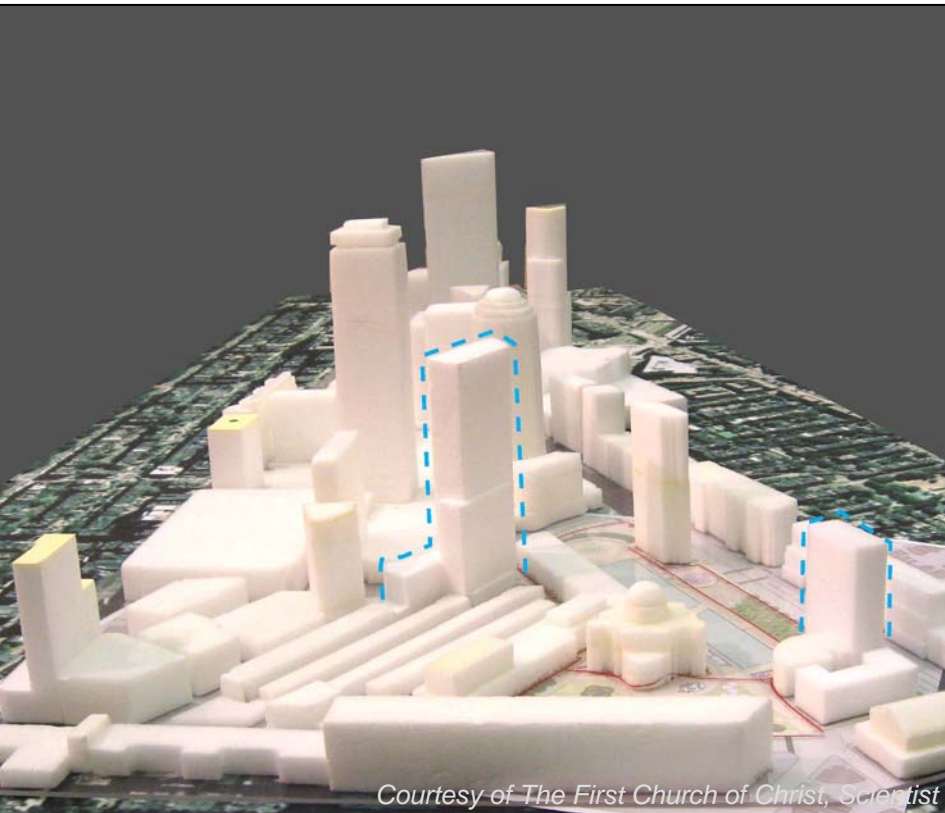

PREVIOUS PROPOSAL

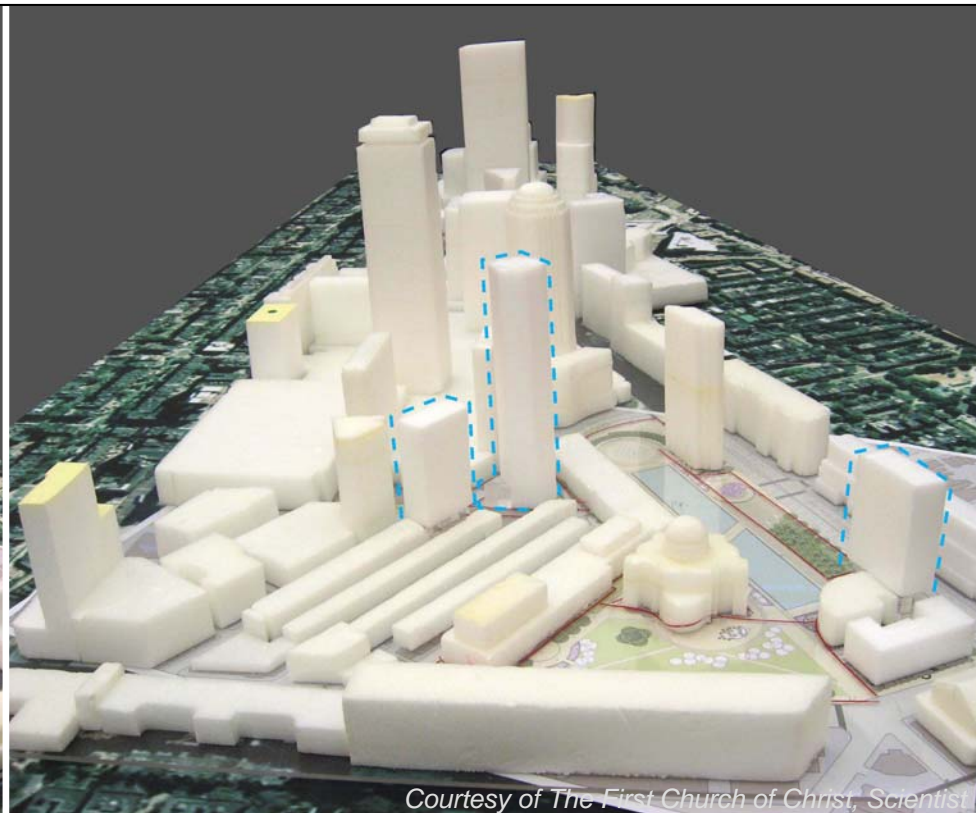

CURRENT PROPOSAL

CONTEXT MODEL : View from West - - - - -

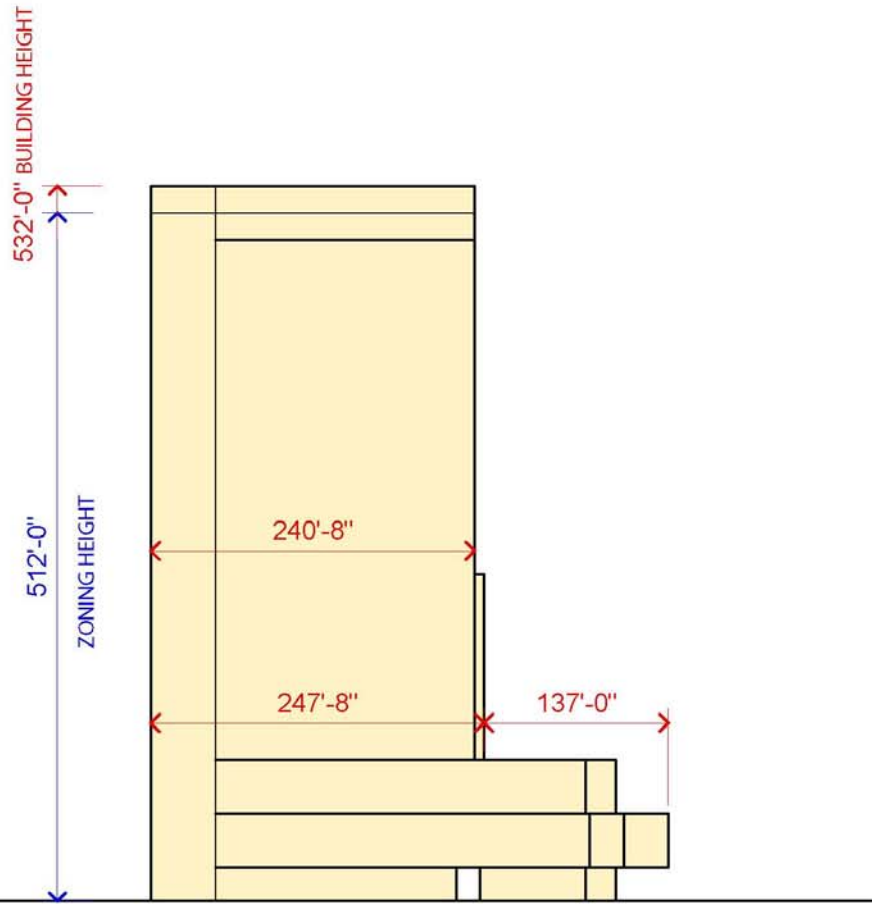

DALTON HIGH-RISE BUILDING

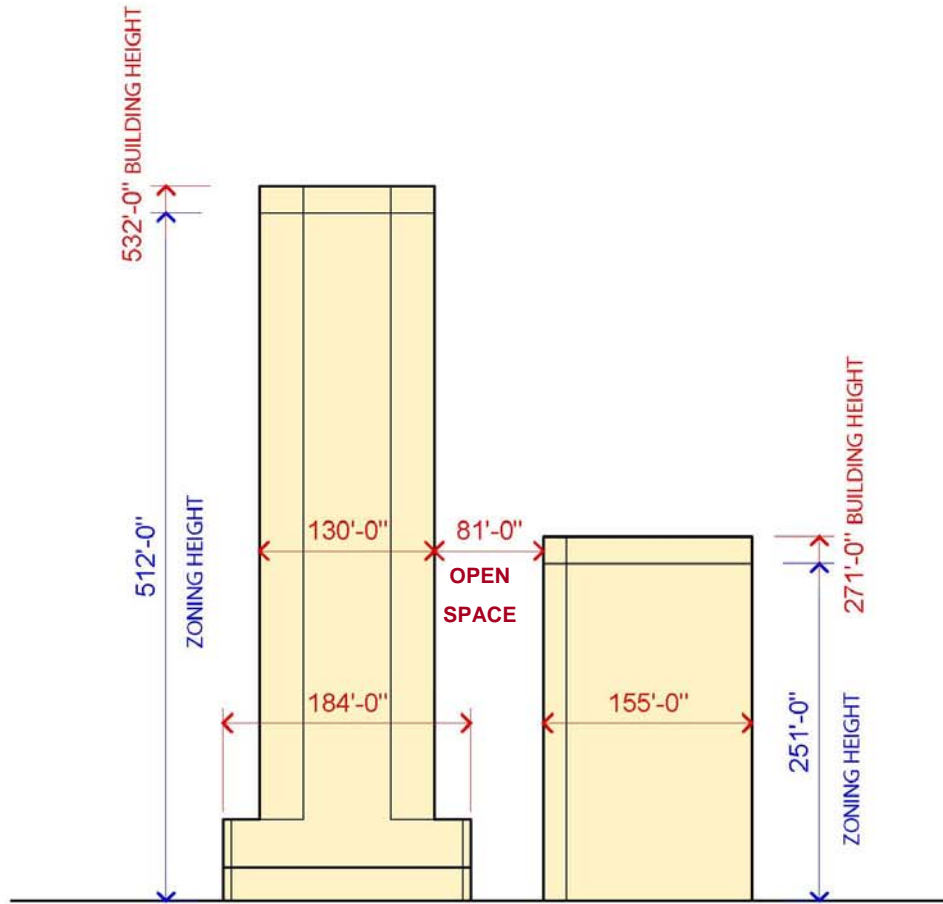

DALTON HIGH-RISE BLDG

DALTON MID-RISE BLDG

PREVIOUS PROPOSAL

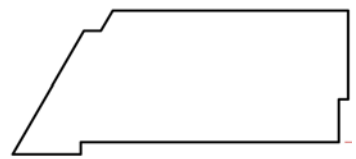

CURRENT PROPOSAL

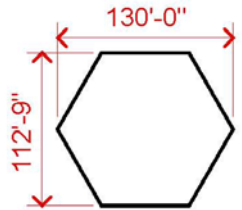

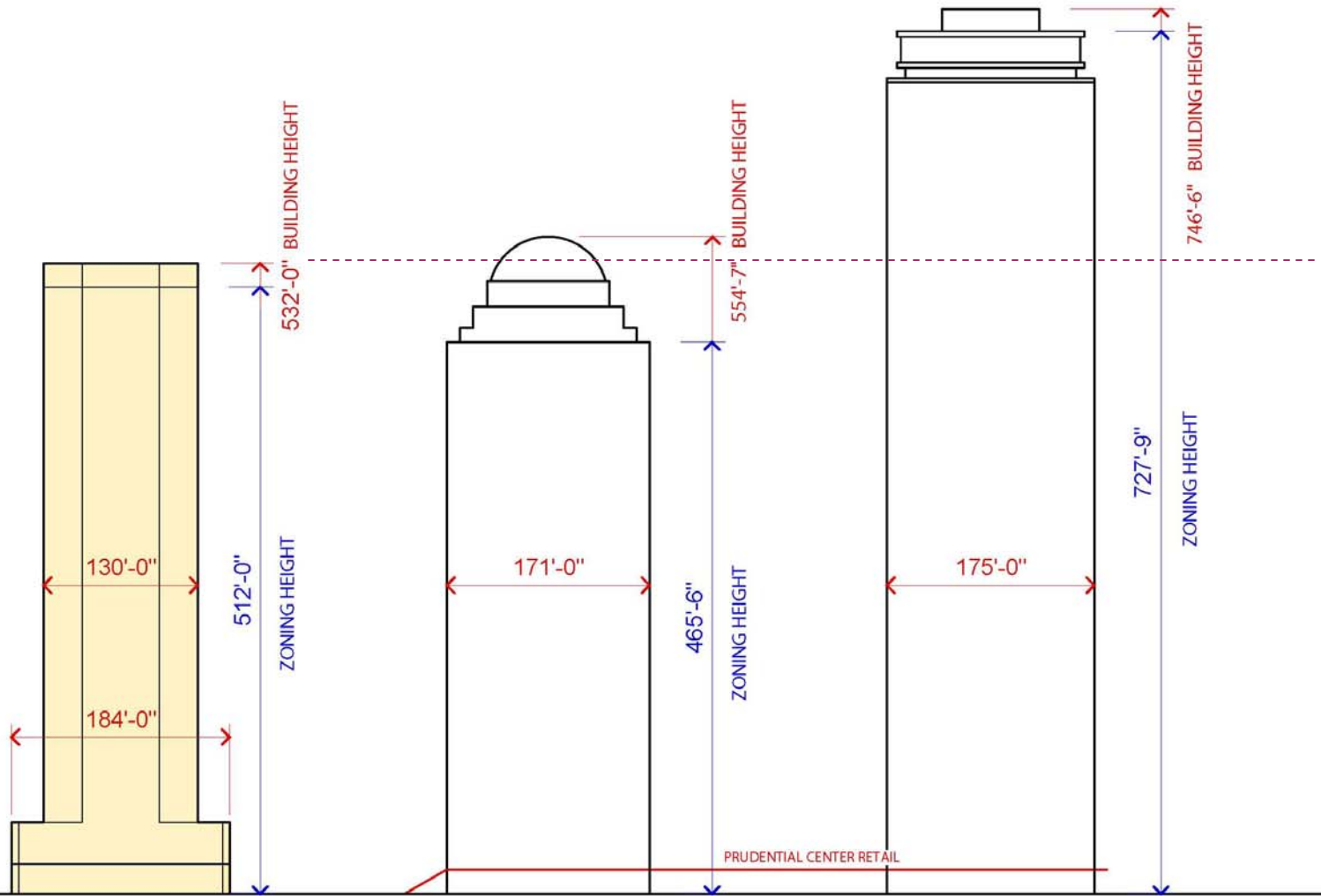

DALTON HIGH-RISE BLDG

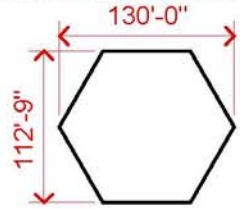

111 HUNTINGTON

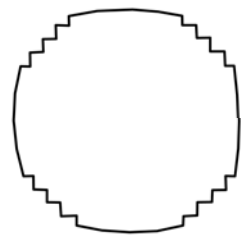

PRUDENTIAL TOWER

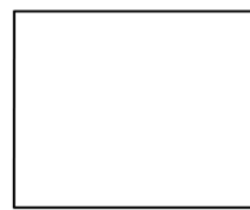

Courtesy of The First Church of Christ, Scientist

CONTEXT ELEVATIONS : Dalton Site - Dalton High-Rise Building

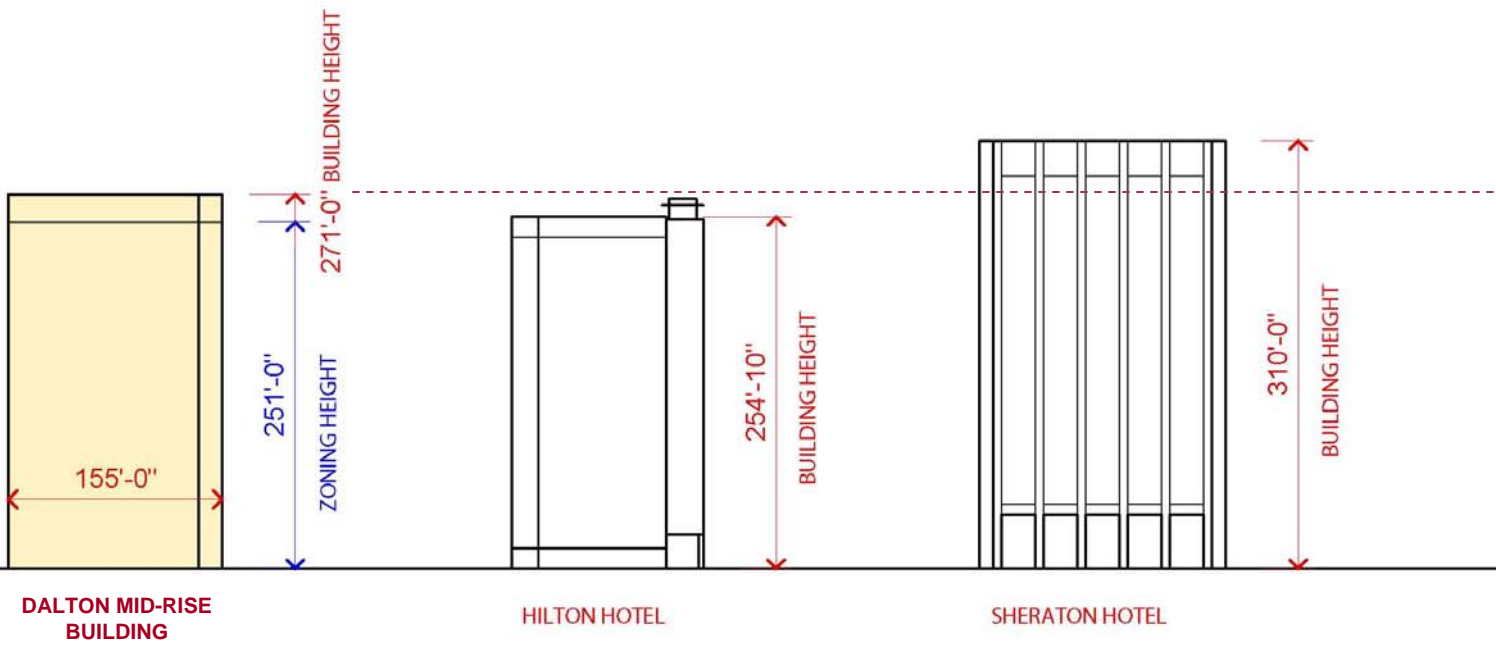

Courtesy of The First Church of Christ, Scientist

CONTEXT ELEVATIONS : Dalton Site - Dalton Mid-Rise Building

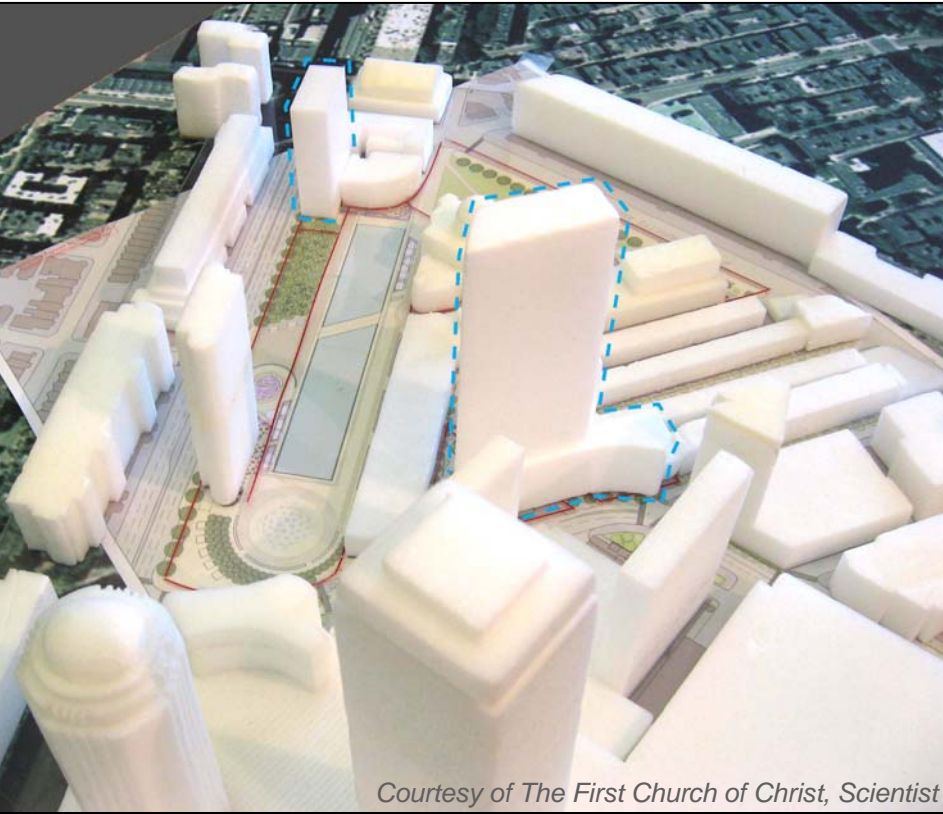

PREVIOUS PROPOSAL

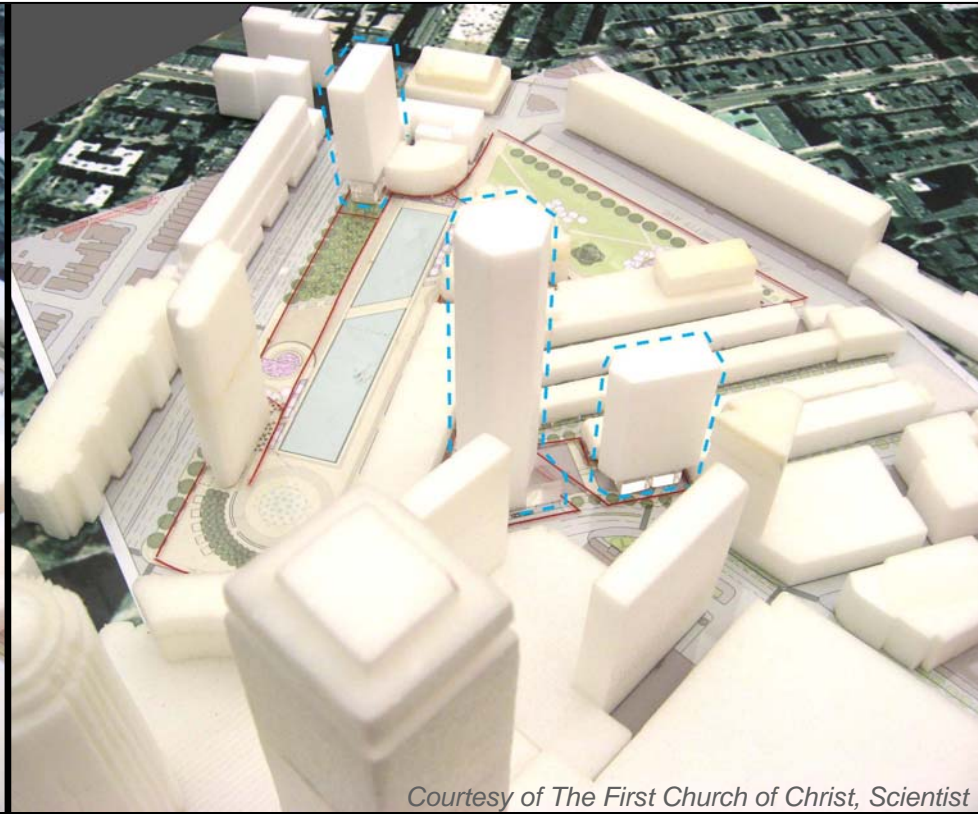

CURRENT PROPOSAL

CONTEXT MODEL : View from Prudential Center - - - - -

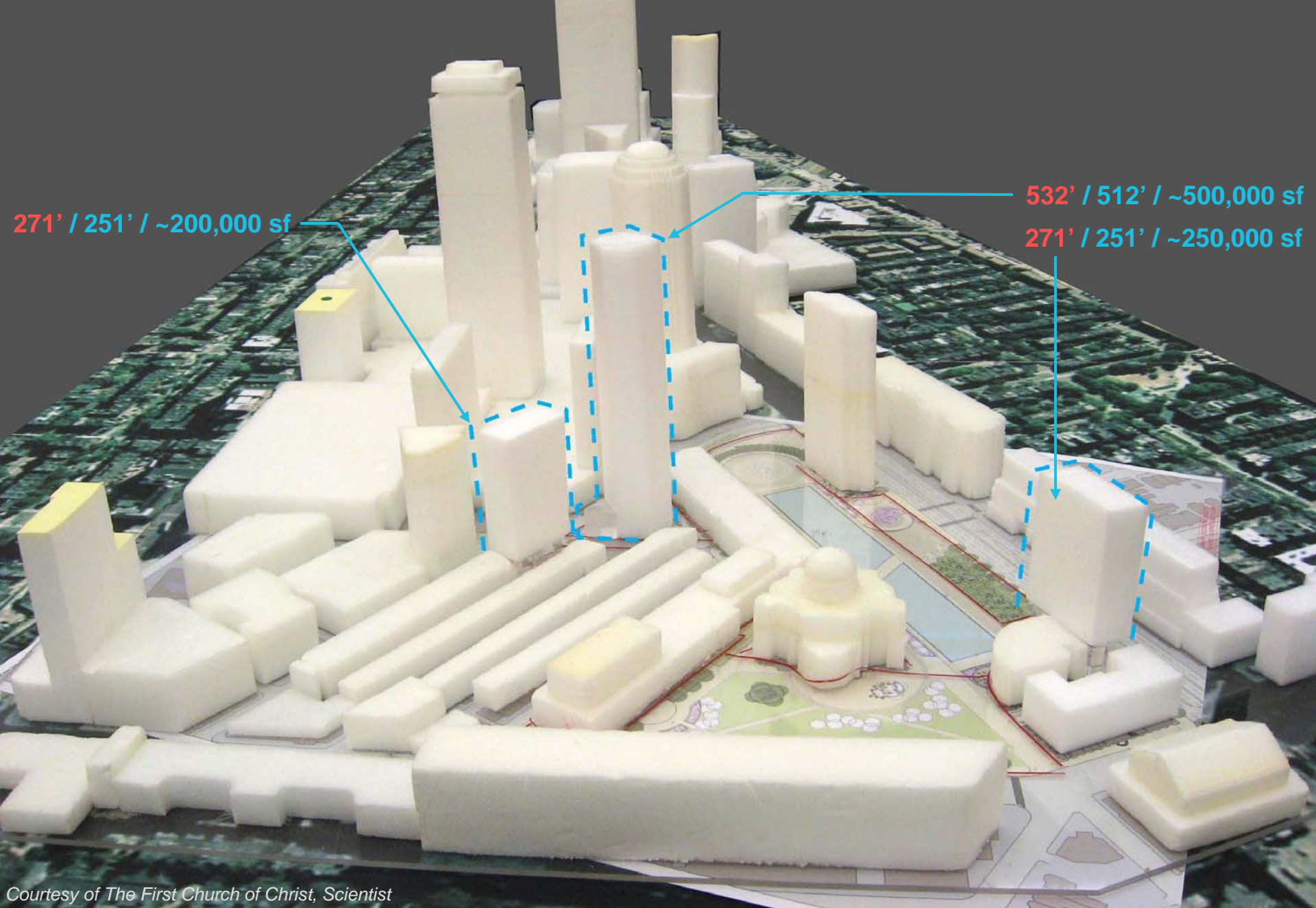

Courtesy of The First Church of Christ, Scientist

MASSING HEIGHT

ZONING HEIGHT & SQUARE FOOTAGE - - - - -

CURRENT PROPOSAL : Context Model View