



BOSTON INSPECTIONAL SERVICES DEPARTMENT

THOMAS M. MENINO
Mayor

December 4, 2013

Silvana Sawaya
1839 Washington St
Newton, MA 02466

RE:

Permit Address: 7 Eliot St
Ward: 19
Permit Application #: ALT296961

Attention Applicant:

The following information shall be provided to ISD to complete Building Permit review process:

- a) BRA design review in accordance with Article 55 Section 55-36 (Design Review and Design Guidelines) and Article 80, Small Project Review, Design Component, Section 80E-2.1(b)(iii)

Other information may be required

This information can be dropped off at our office with the above referenced application number. Thank you for your assistance.

Luis Santana
Plans Examiner
617 961-3286





AI

Silvana Sawaya Architect
1839 Washington Street
Newton, MA 02466 tel: 617.243.0698

Perspective
Scale: N.T.S.
Date: 10/17/13
First Street plan drawing

7 ELIOT STREET
JAMAICA PLAIN, MA

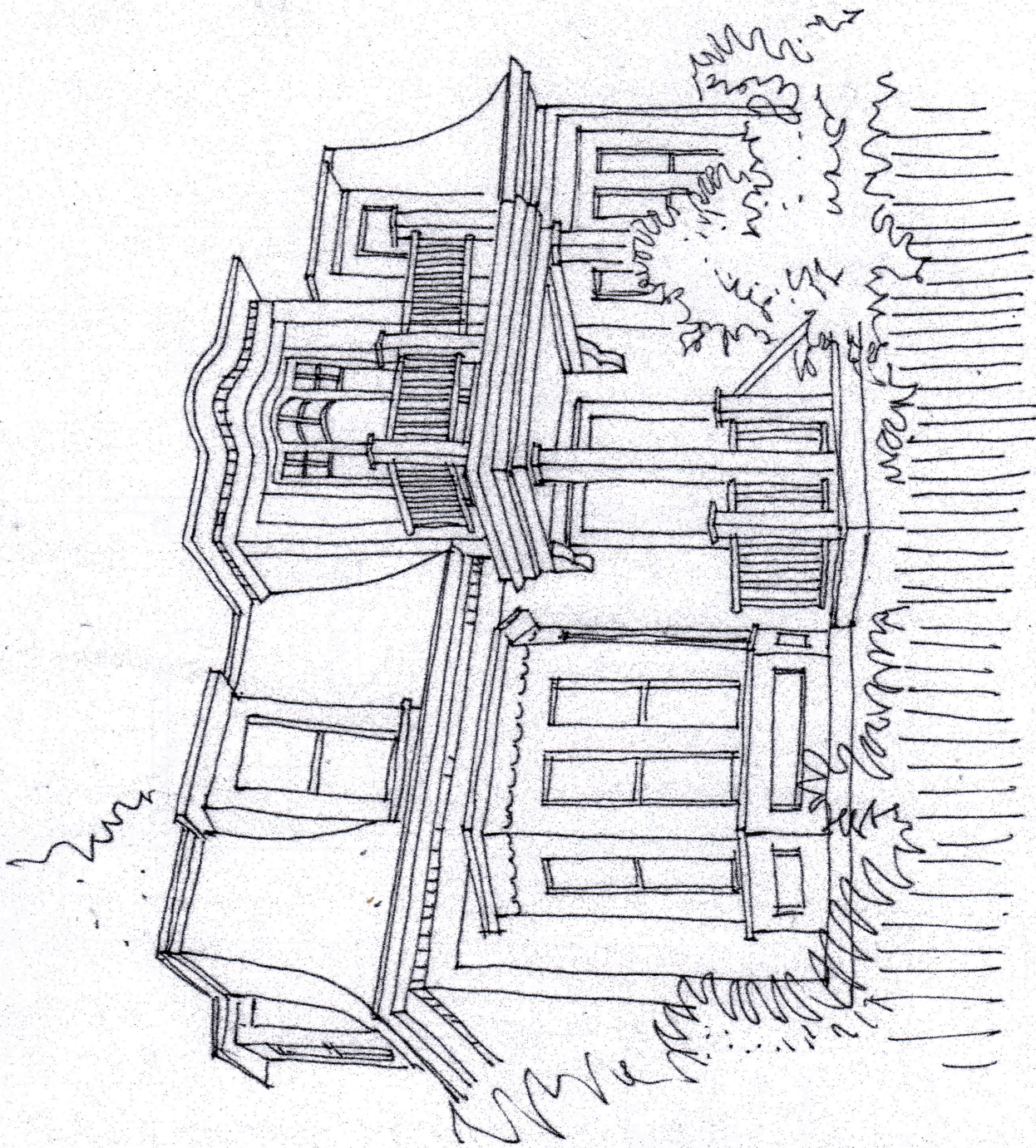
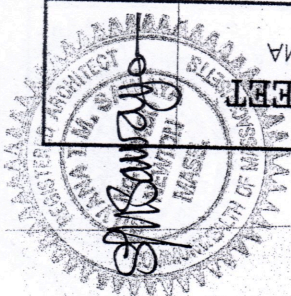

① Perspective Sketch
Scale: Not to Scale

WALLS & FLOOR
DEMOLITION:
1. STRIP FLOOR
FINISHES DOWN
TO PLYWOOD.
2. REMOVE WALLS
DOWN TO
PLYWOOD DECKING
WHICH WILL
REMAIN.
3. REMOVE
WINDOWS IN
LOCATION SHOWN

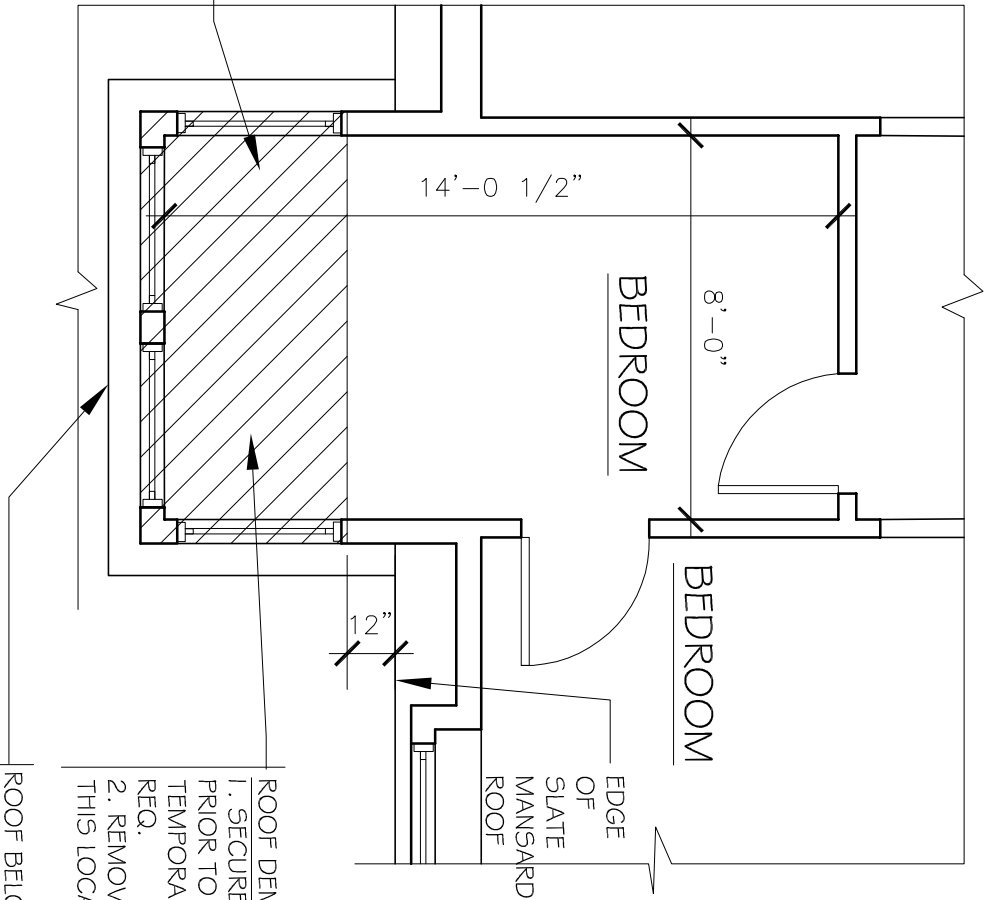

EDGE
OF
SLATE
MANSARD
ROOF

ROOF DEMOLITION:
1. SECURE EXISTING RAFTERS
PRIOR TO DEMOLITION USING
TEMPORARY SUPPORTS AS
REQ.
2. REMOVE EXISTING ROOF
THIS LOCATION ONLY.

ROOF BELOW:
REMOVE SHINGLES
ONLY; ROOF DECKING,
FRAMING & FASCIA TO
REMAIN.

① Plan of Existing & Demolition
Scale: 1/4" = 1'-0"

Existing Plan	
Scale: 1/4" = 1'-0"	Revisions:
Date: 10/17/13	
Eliot Street plans.dwg	

7 ELIOT STREET
JAMAICA PLAIN, MA

A2

Silvana Sawaya Architect
1839 Washington Street
Newton, MA 02466 tel:617.243.0698

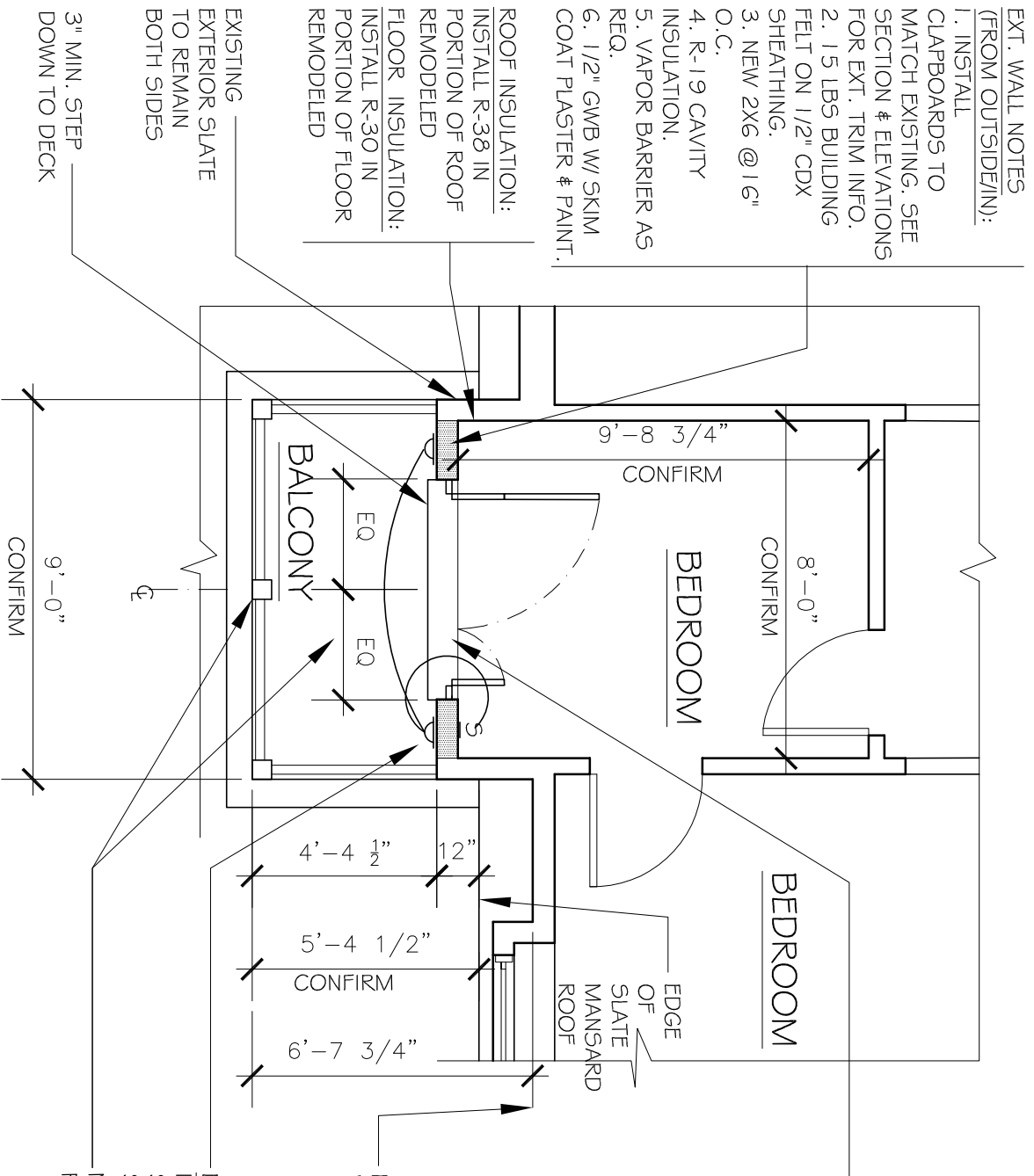

EXT. WALL NOTES
(FROM OUTSIDE/IN):

1. INSTALL CLAPBOARDS TO MATCH EXISTING. SEE SECTION & ELEVATIONS FOR EXT. TRIM INFO.
2. 1.5 LBS BUILDING FELT ON 1/2" CDX SHEATHING.
3. NEW 2X6 @ 16" O.C.
4. R-19 CAVITY INSULATION.
5. VAPOR BARRIER AS REQ.
6. 1/2" GWB W/ SKIM COAT PLASTER & PAINT.

ROOF INSULATION:
INSTALL R-38 IN PORTION OF ROOF REMODELED

FLOOR INSULATION:
INSTALL R-30 IN PORTION OF FLOOR REMODELED

EXISTING EXTERIOR SLATE TO REMAIN BOTH SIDES

3" MIN. STEP DOWN TO DECK

INSTALL NEW TRIPLE FRENCH DOOR:

1. PROTECT EXISTING HARDWOOD FLOOR TO REMAIN.
2. FRAME OUT NEW OPENING W/ 2-2X6 POSTS @ SIDES & 2-2X8 W/ PLYWD HEADER.
3. CONFIRM DOOR ROUGH DIMENSIONS BEFORE FRAMING OPENING. SUPPLIER DIMENSIONS ARE: R.O.: 5'-2 1/2" W. x 7'-11 3/4" H. DOOR INCLUDES EXTERIOR TRIM, HARDWARE & THRESHOLD.
4. INSULATE ALL AROUND DOOR W/ NON EXPANSION FOAM INSULATION.
5. PROVIDE FLASHING @ DOOR HEAD & @ THRESHOLD AS PER DETAILS.

LINE OF EXTERIOR WALL BELOW

ELECTRICAL:
INSTALL WALL SCONCES W/ INSIDE SWITCH

NEW DECKING, POSTS & RAILING. SEE DETAILS.

1 Proposed Plan
Scale: 1/4" = 1'-0"

Proposed Plan	
Scale: 1/4" = 1'-0"	Revisions:
Date: 10/17/13	
Eliot Street plans.dwg	

7 ELIOT STREET
JAMAICA PLAIN, MA

A3

Silvana Sawaya Architect
1839 Washington Street
Newton, MA 02466 tel:617.243.0698

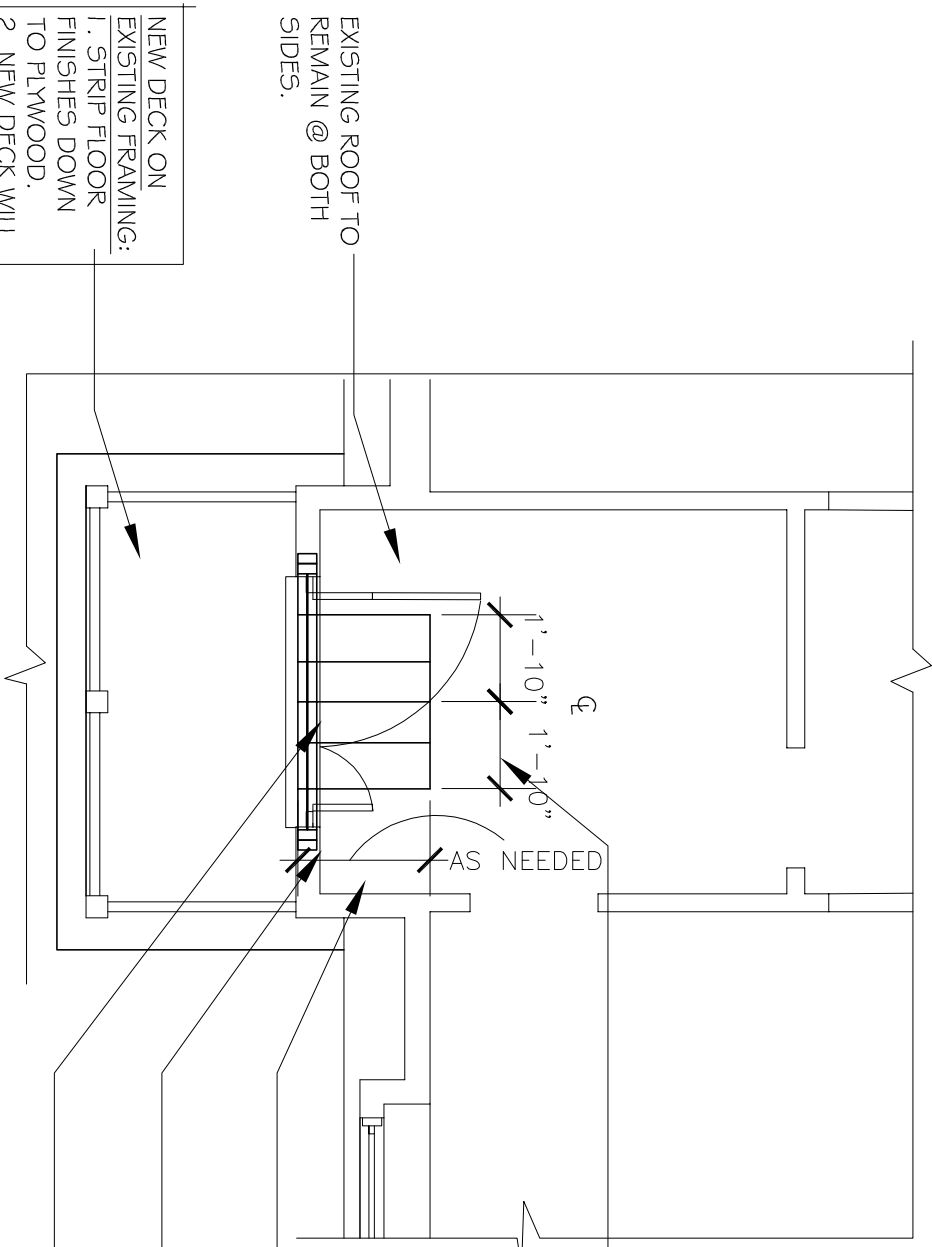

NEW DECK ON EXISTING FRAMING:
 1. STRIP FLOOR FINISHES DOWN TO PLYWOOD.
 2. NEW DECK WILL BE INSTALLED OVER EXISTING FRAMING, SEE SECTION DETAILS.

EXISTING ROOF TO REMAIN @ BOTH SIDES.

ARCHED ROOF:
 1. OVERFRAME 2X4 RAFTERS TO CREATE ARCHED ROOF @ LOCATION SHOWN IN PLAN.

EXISTING ROOF TO REMAIN @ BOTH SIDES.

NEW 2-2X6 POST @ EACH SIDE OF DOOR OPENING, TYP.

NEW 2-2X6 HEADER W/ 2- $\frac{1}{2}$ " PLYWOOD IN BETWEEN OVER DOOR OPENING, TYP.

CONFIRM

① Framing Plan
 Scale: 1/4" = 1'-0"

Framing Plan	
Scale: 1/4" = 1'-0"	Revisions:
Date: 10/17/13	
Eliot Street plans.dwg	

7 ELIOT STREET
 JAMAICA PLAIN, MA

A4

Silvana Sawaya Architect
 1839 Washington Street
 Newton, MA 02466 tel:617.243.0698

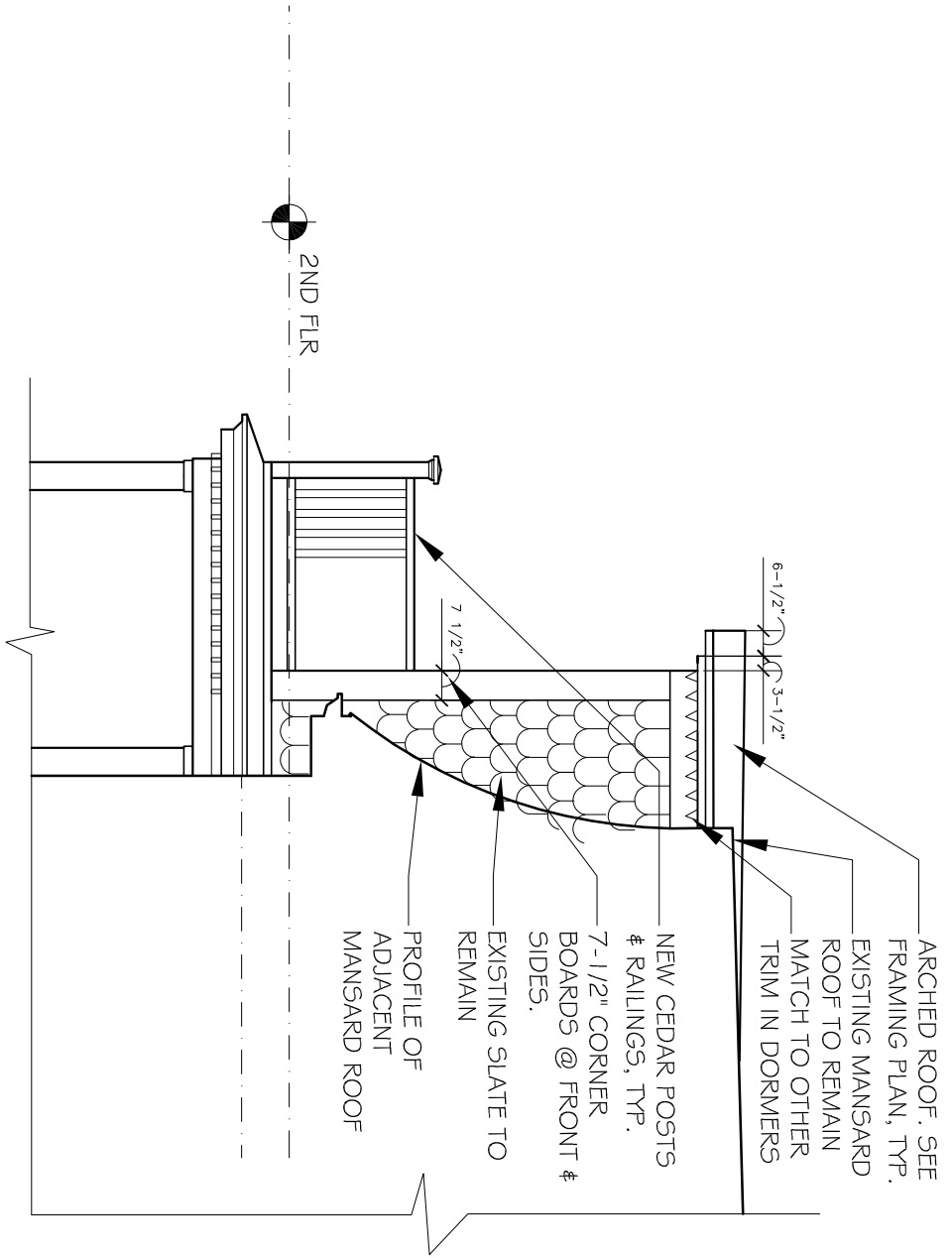

2ND FLR

① Side Elevation
Scale: 1/4" = 1'-0"

A5	Silvana Sawaya Architect	Elevations		7 ELIOT STREET JAMAICA PLAIN, MA
	1839 Washington Street Newton, MA 02466 tel:617.243.0698	Scale: 1/4" = 1'-0"	Revisions:	
		Date: 10/17/13		
		Eliot Street plans.dwg		

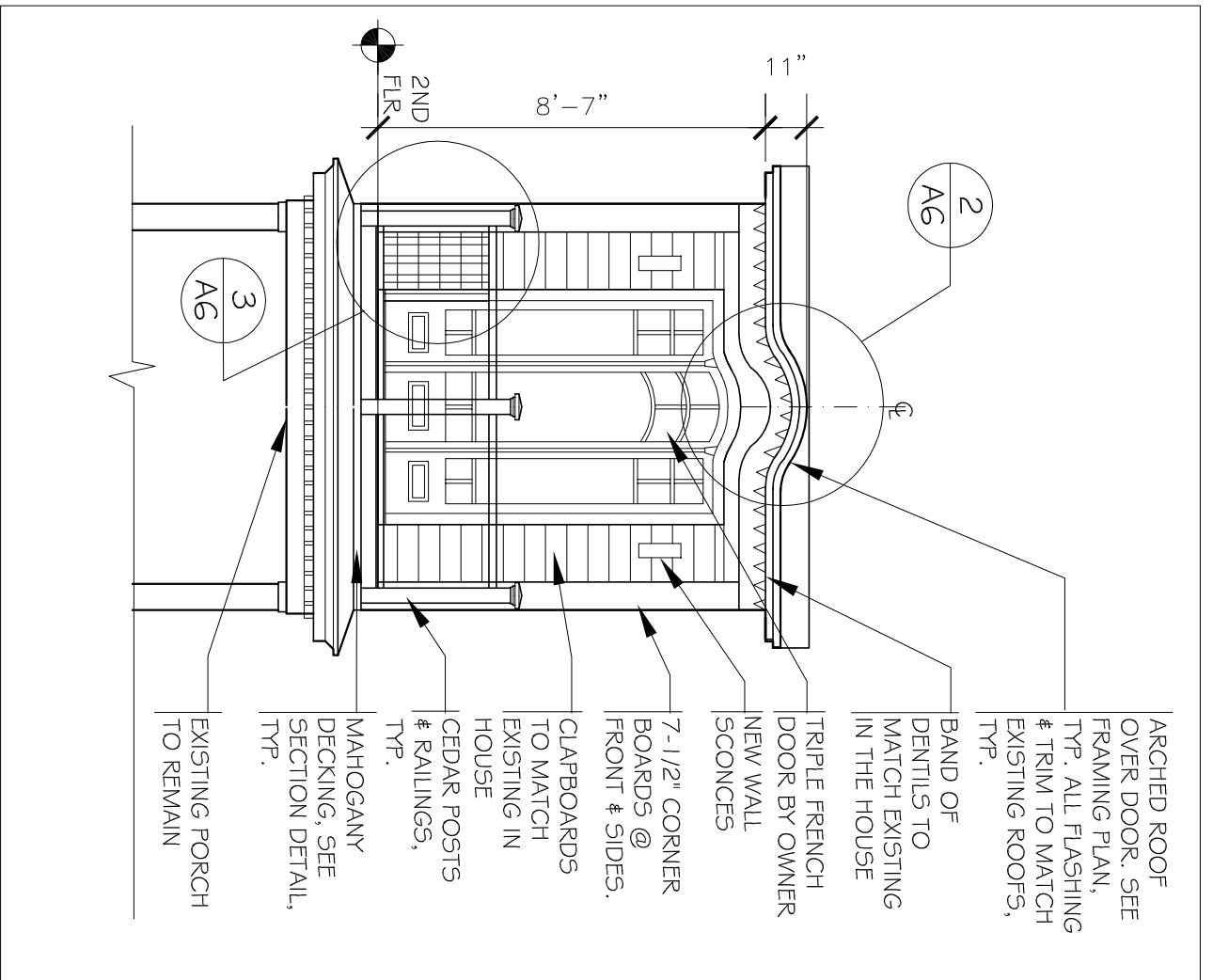

1 Front Elevation
Scale: 1/4" = 1'-0"

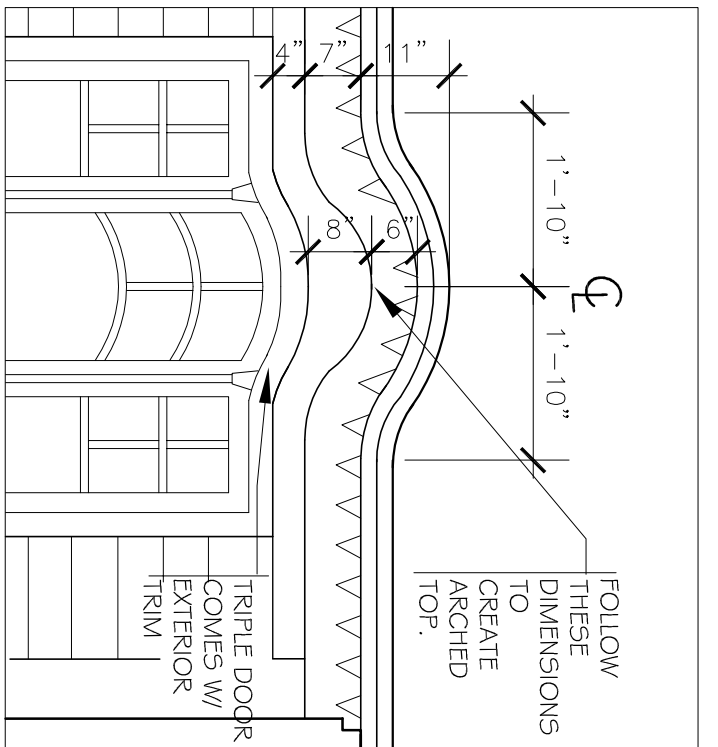

2 Arched Top Detail
Scale: 1/2" = 1'-0"

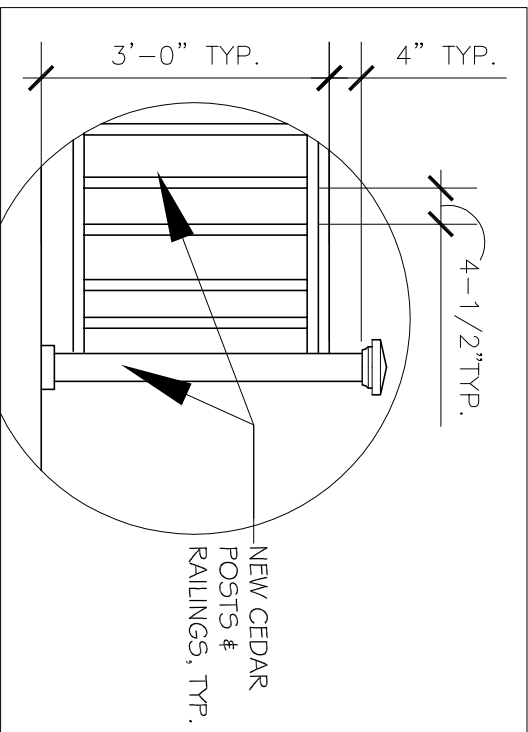

3 Post & Railing Detail
Scale: 1/2" = 1'-0"

Elevations	
Scale: Varies	Revisions:
Date: 10/17/13	
Eliot Street plans.dwg	

7 ELIOT STREET
JAMAICA PLAIN, MA

A6

Silvana Sawaya Architect
1839 Washington Street
Newton, MA 02466 tel:617.243.0698

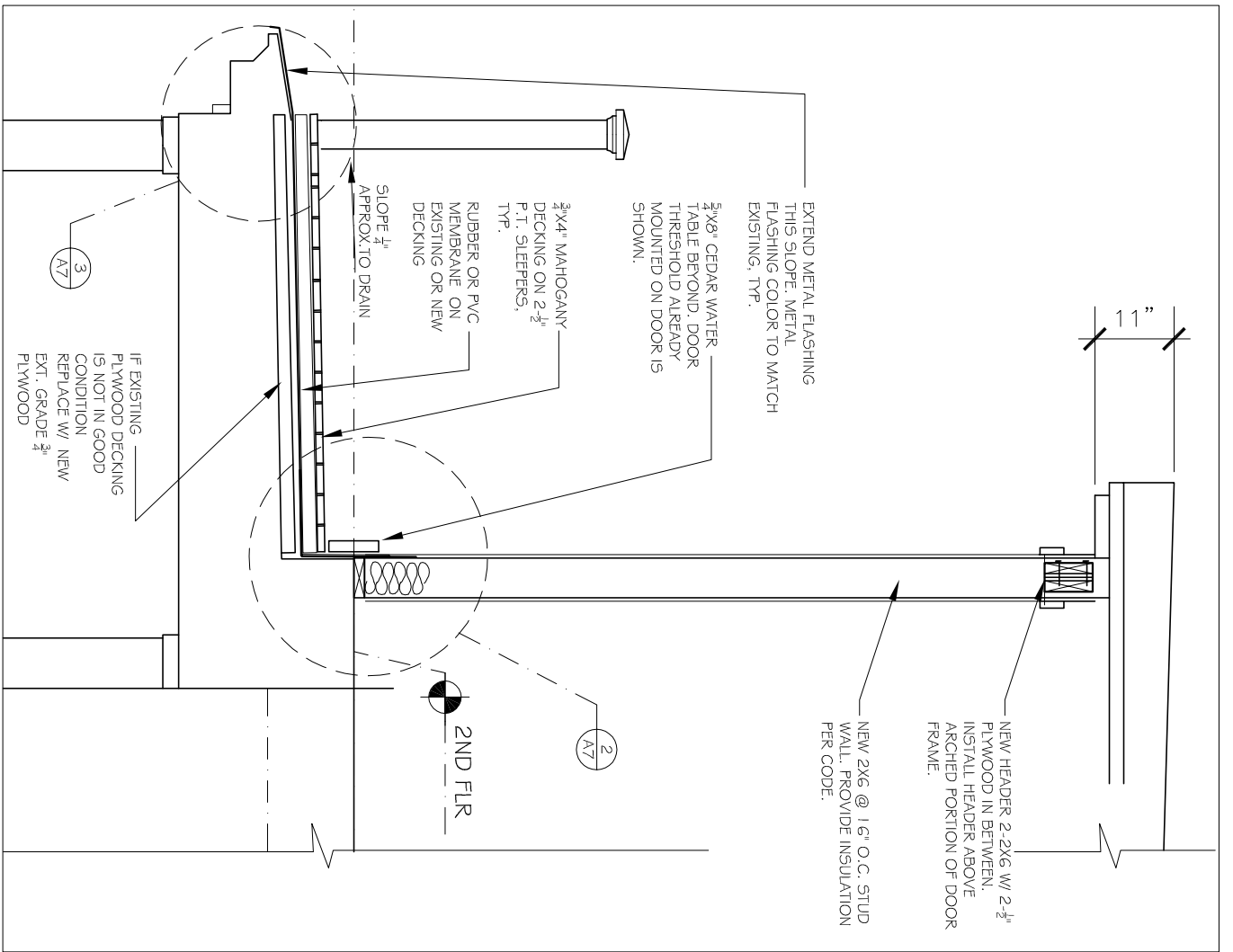

1 Front Elevation
Scale: 1/4" = 1'-0"

