

# 115 WINTHROP SQUARE

BCDC MEETING  
PNF FILING PRESENTATION

FEBRUARY 07, 2017

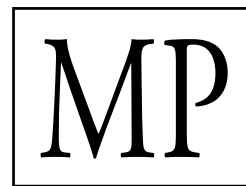

MILLENNIUM PARTNERS

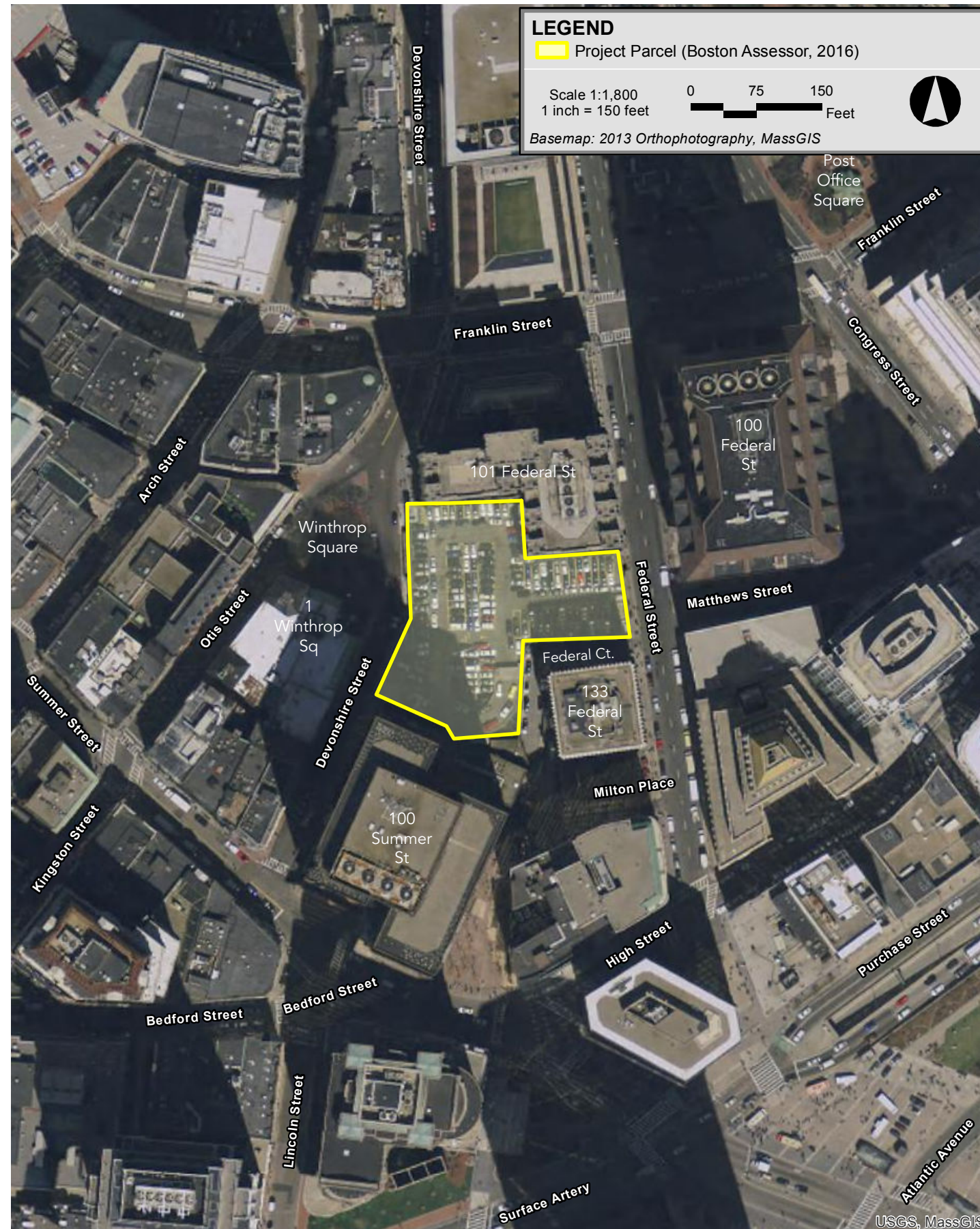





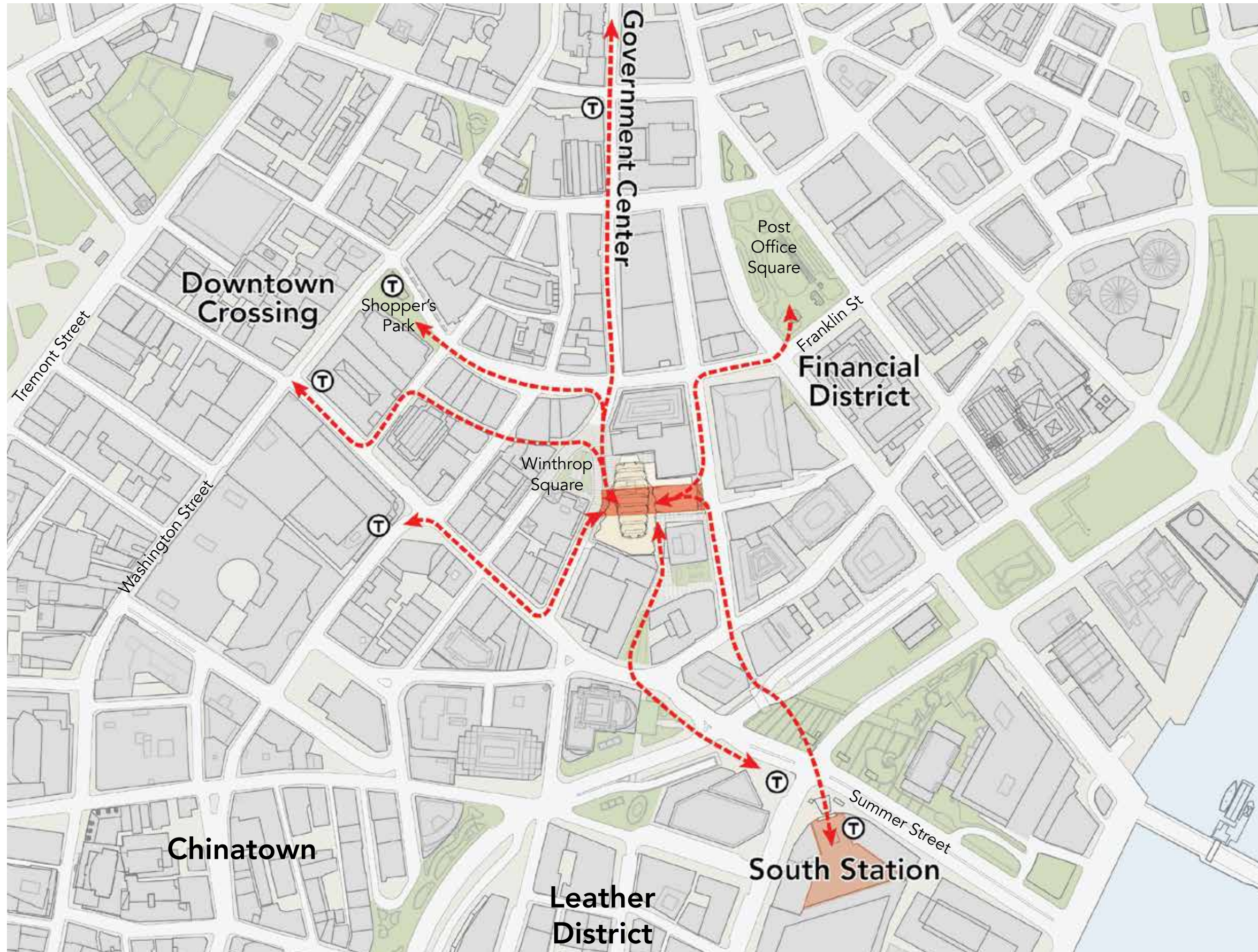

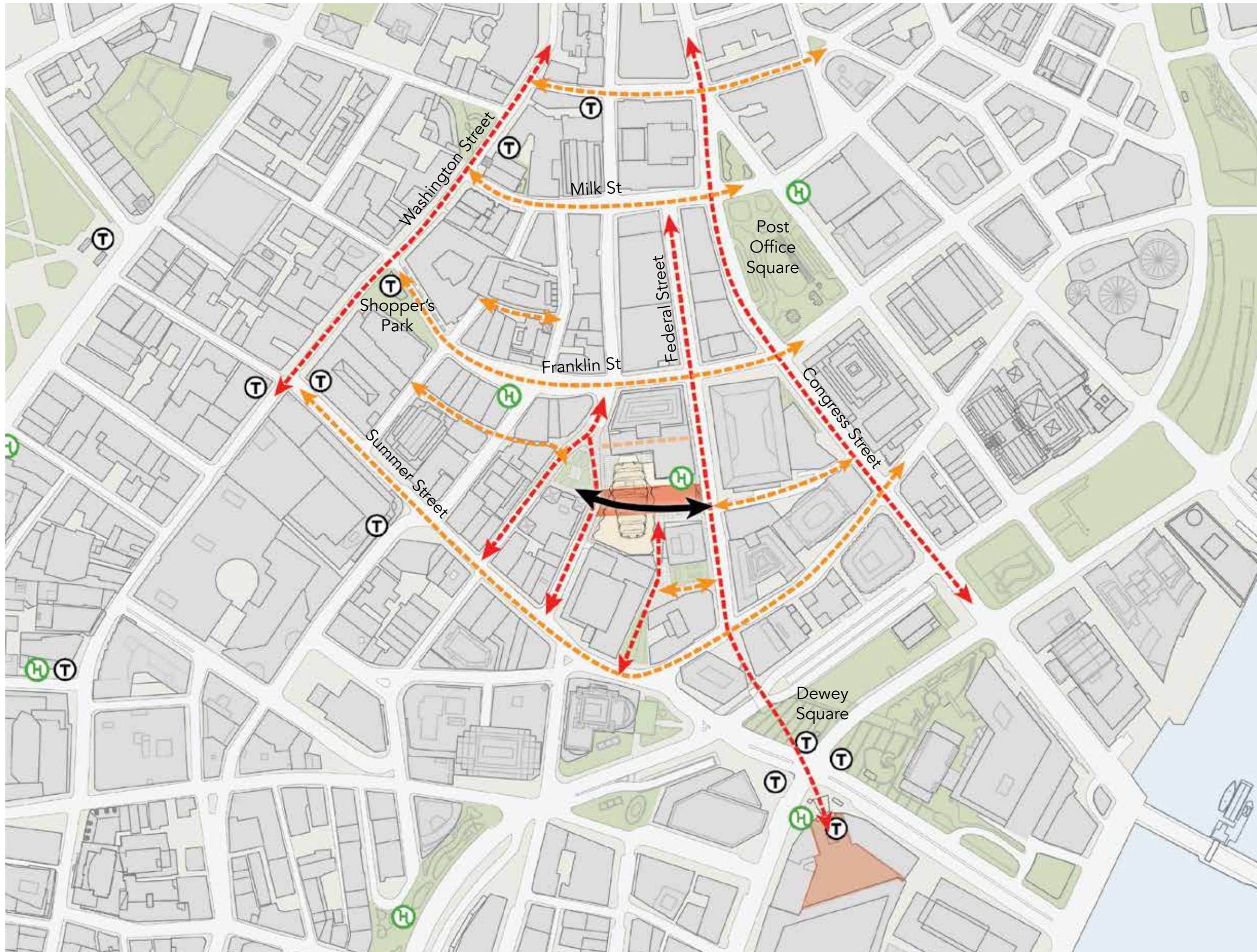

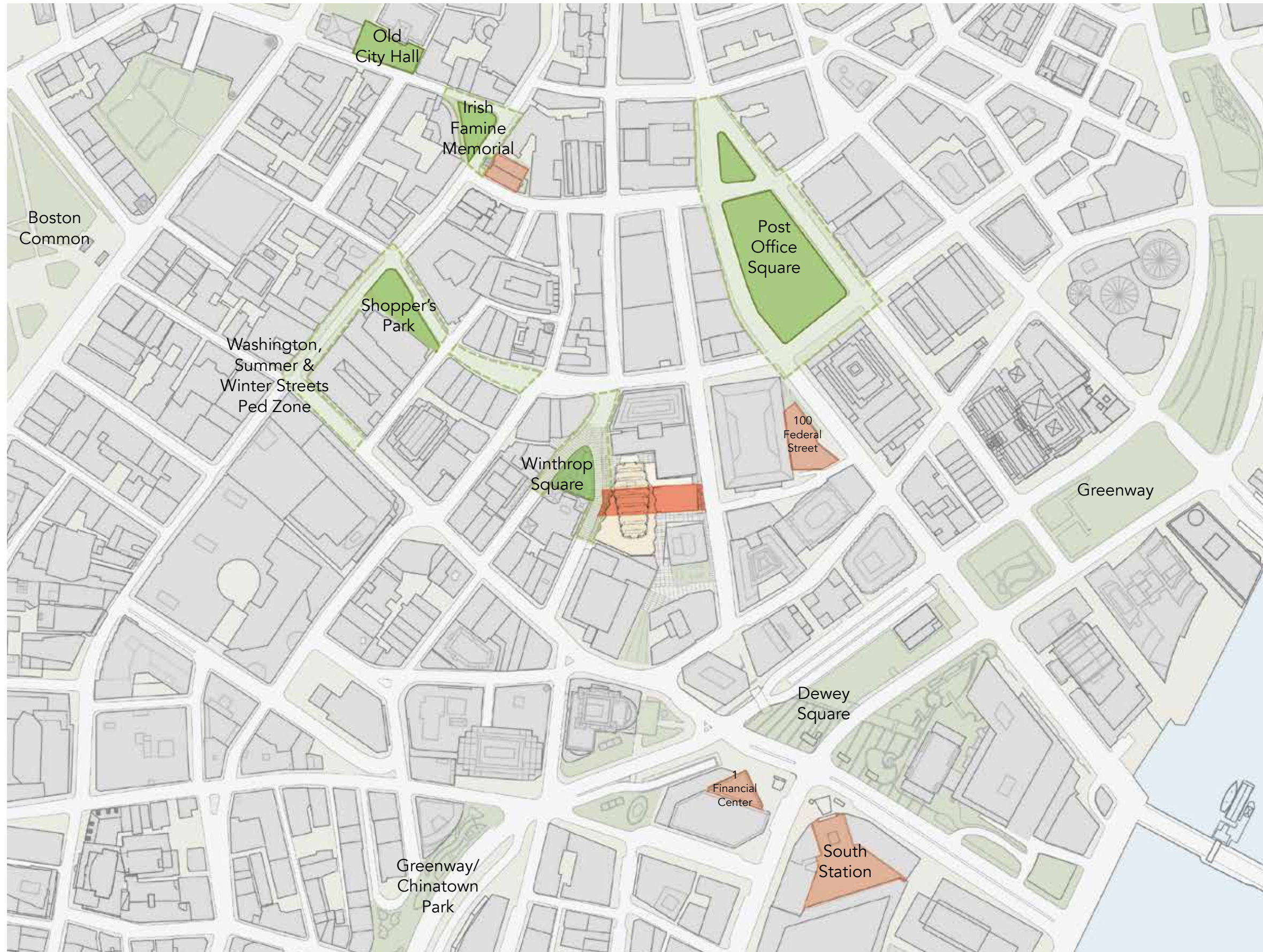



## WINTHROP SQUARE EXISTING CONDITIONS





Boston Public Garden



Christian Science Center



Boston City Hall Plaza



Shopper's Park



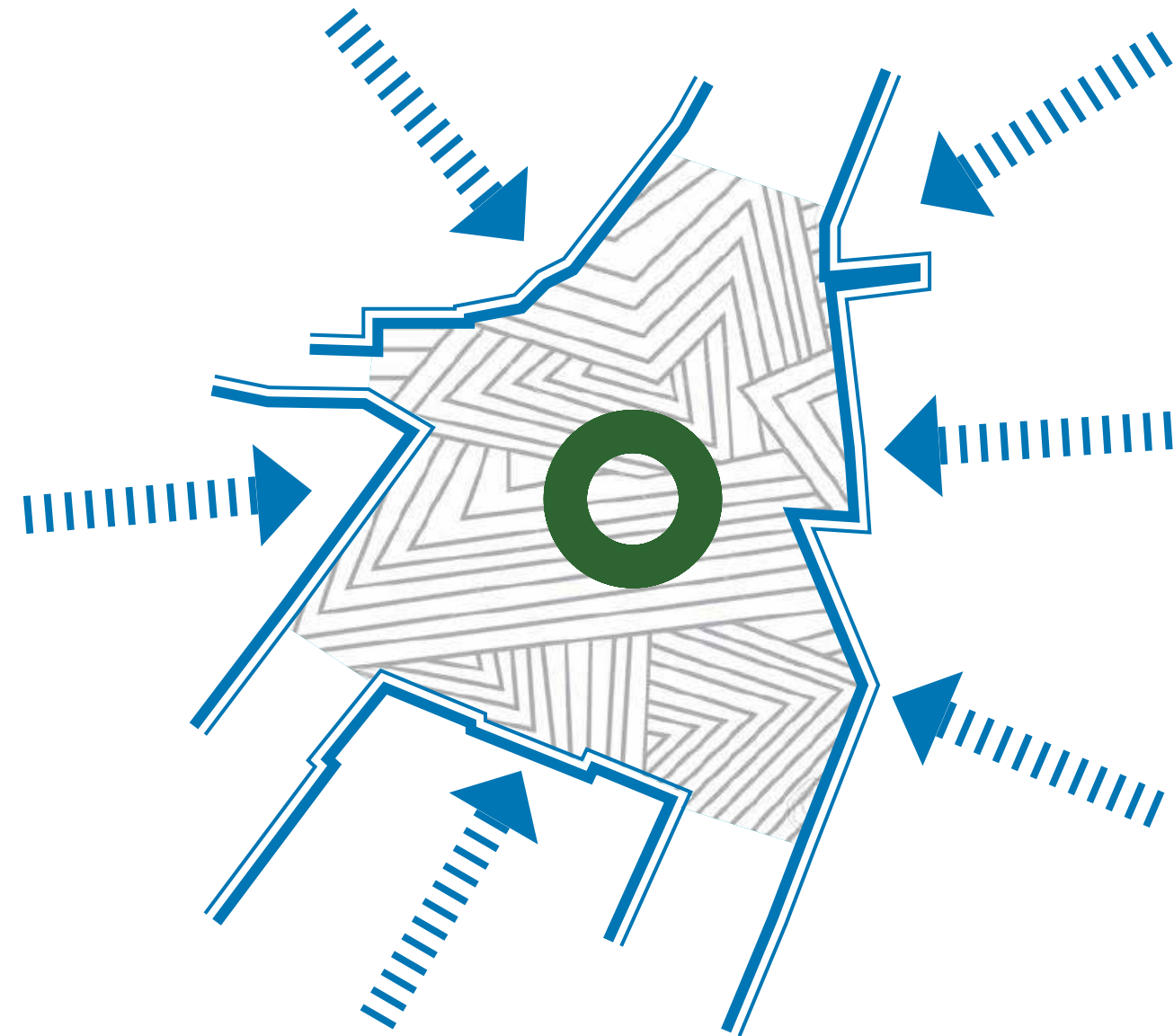



Eating



Sitting



Activities



Art

- LEISURE SPACE  
- SPECIAL EVENT PLACE  
- CONTINUATION OF THE GREAT HALL



Eating



Skating



Performance



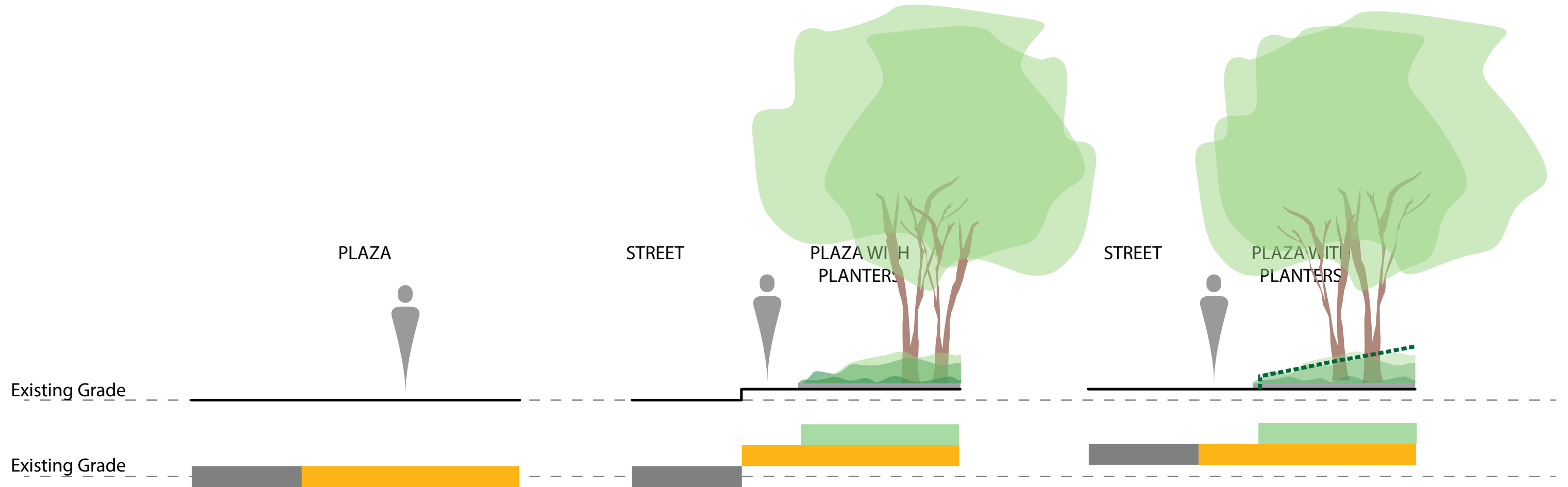

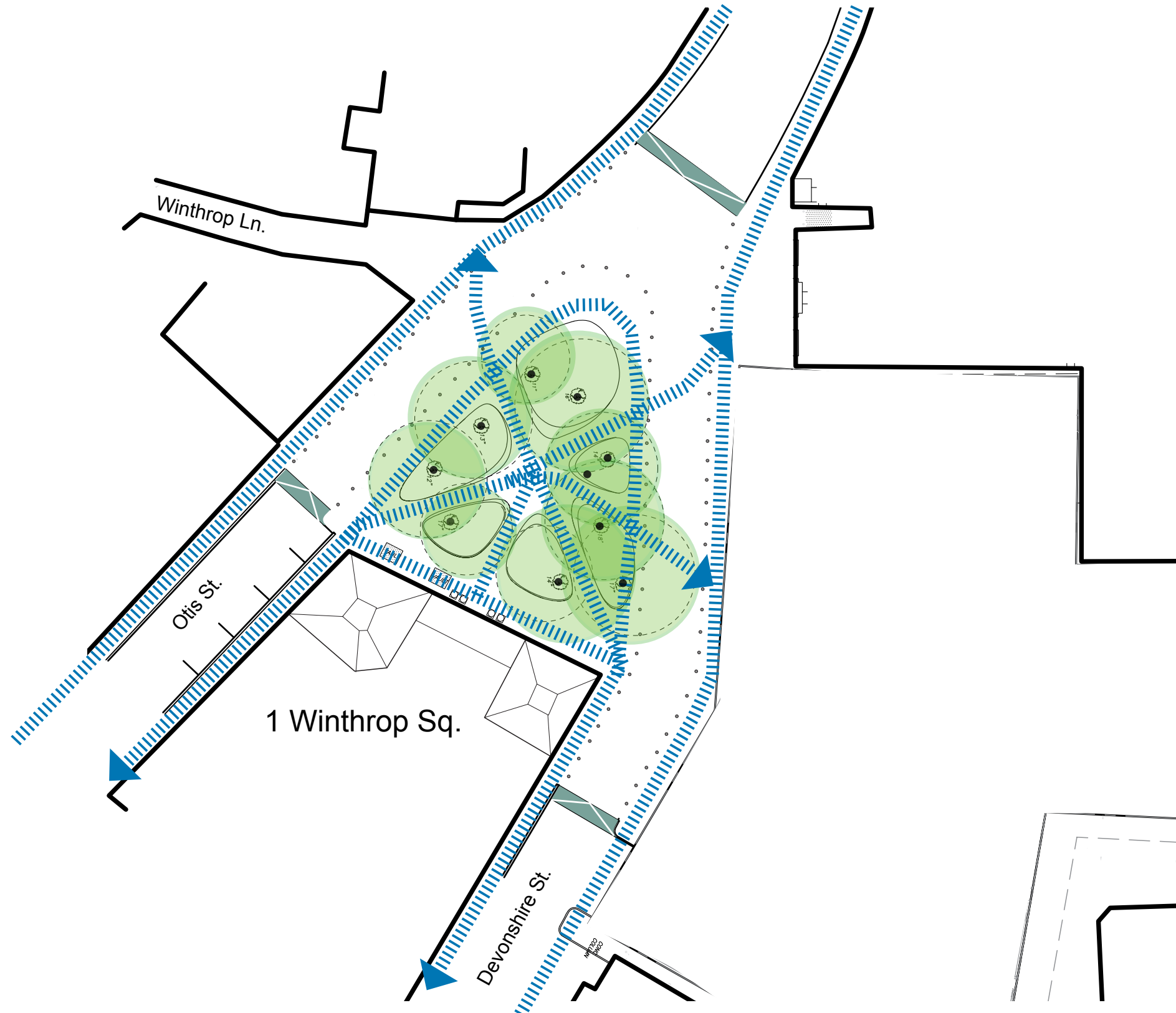

## PEDESTRIAN ACCESS DIAGRAM

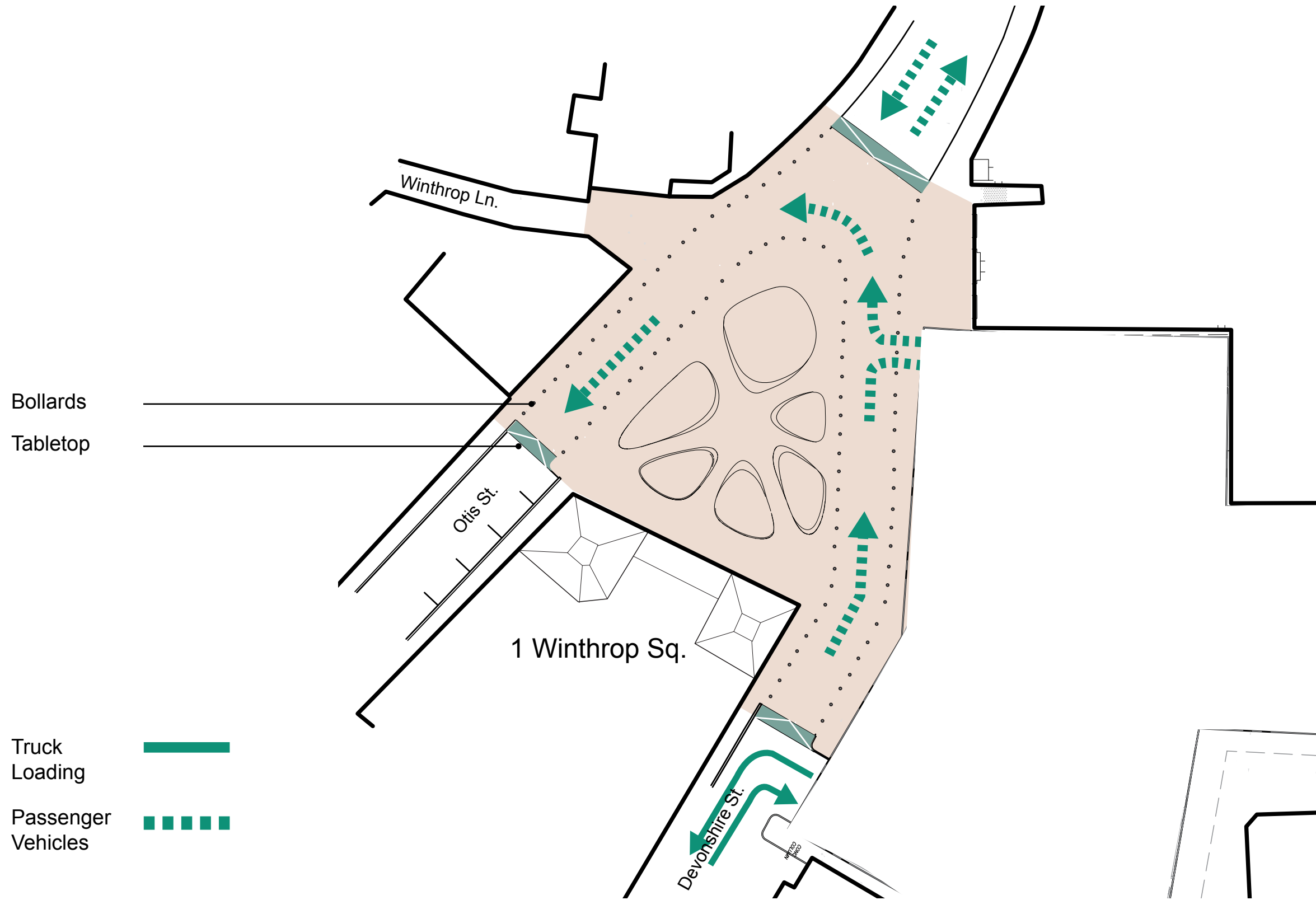





ALL FIGURES & ILLUSTRATIONS APPROXIMATE AND SUBJECT TO CHANGE  
HANDEL ARCHITECTS, D/R/E/A/M COLLABORATIVE & GROUND FOR MILLENNIUM PARTNERS | 07 FEBRUARY 2017

**VIEW FROM GREAT HALL**  
115 WINTHROP SQUARE BCDC PNF FILING PRESENTATION



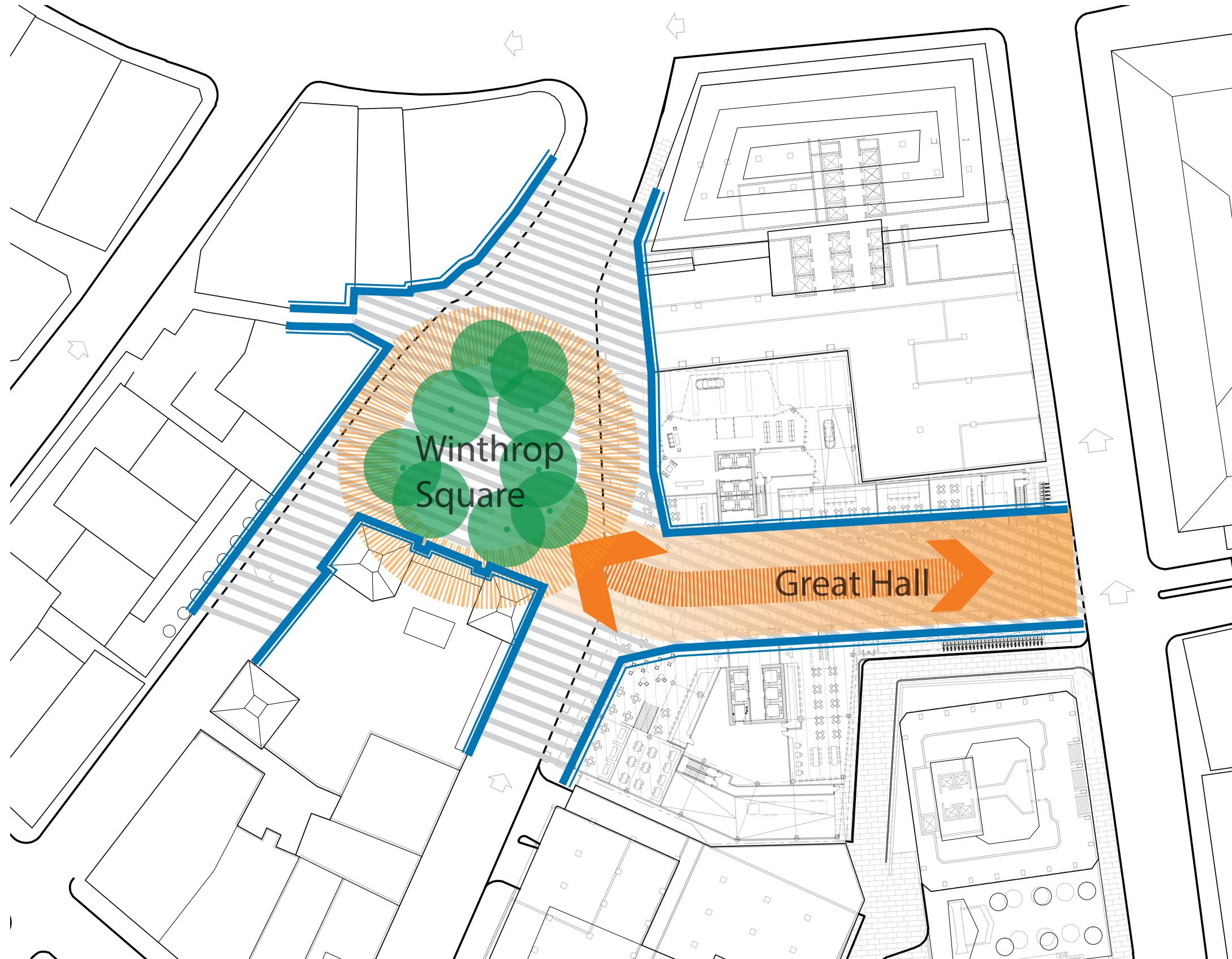

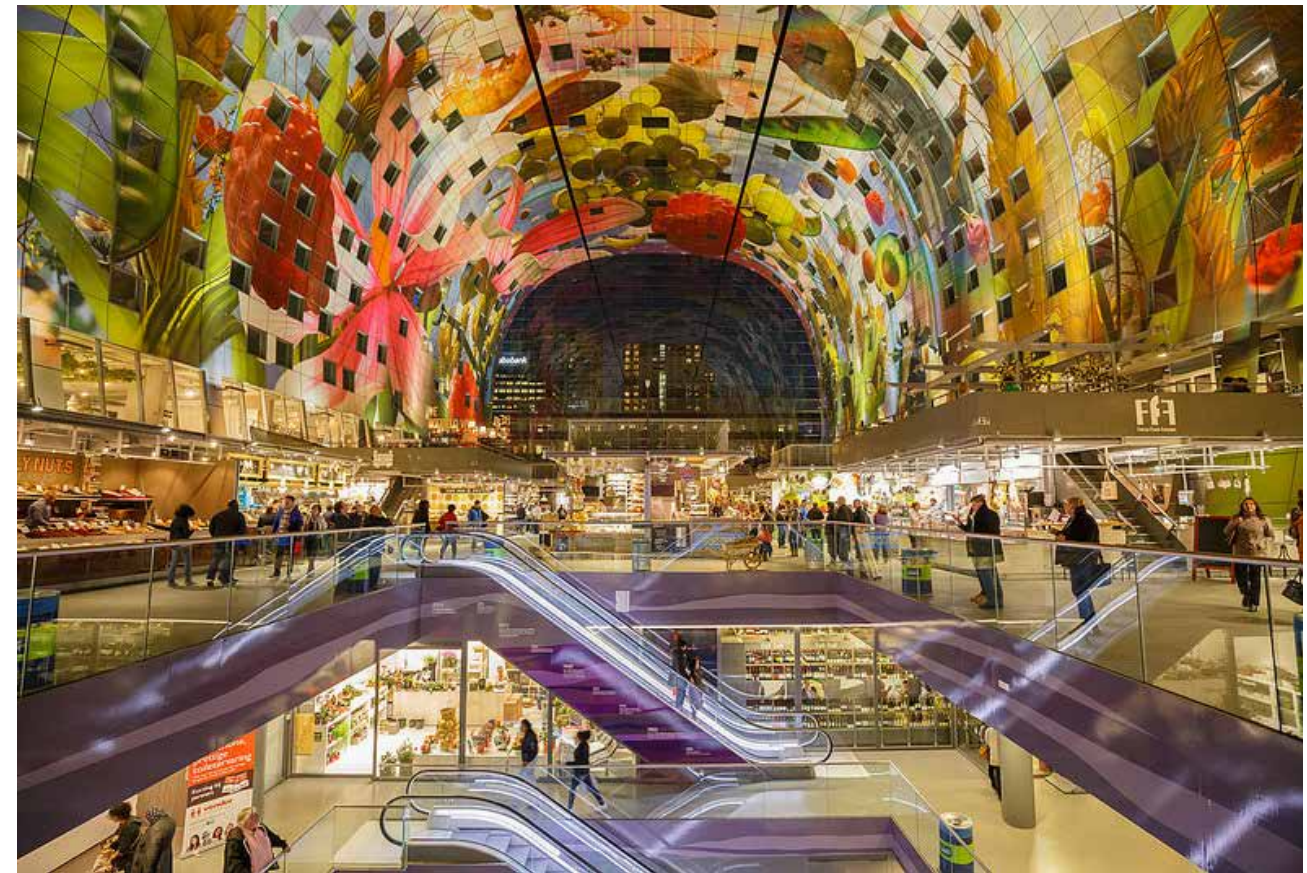





Morning

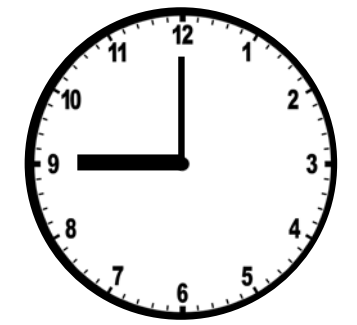

9AM



Lunchtime



1PM



# After Work



6PM



# Evening



8PM





ALL FIGURES & ILLUSTRATIONS APPROXIMATE AND SUBJECT TO CHANGE  
HANDEL ARCHITECTS, D/R/E/A/M COLLABORATIVE & GROUND FOR MILLENNIUM PARTNERS | 07 FEBRUARY 2017

**BOSTON'S LIVING ROOM**  
115 WINTHROP SQUARE BCDC PNF FILING PRESENTATION

# State of the City

**JANUARY**

FEBRUARY

MARCH

APRIL

MAY

JUNE

JULY

AUGUST

SEPTEMBER

OCTOBER

NOVEMBER

DECEMBER

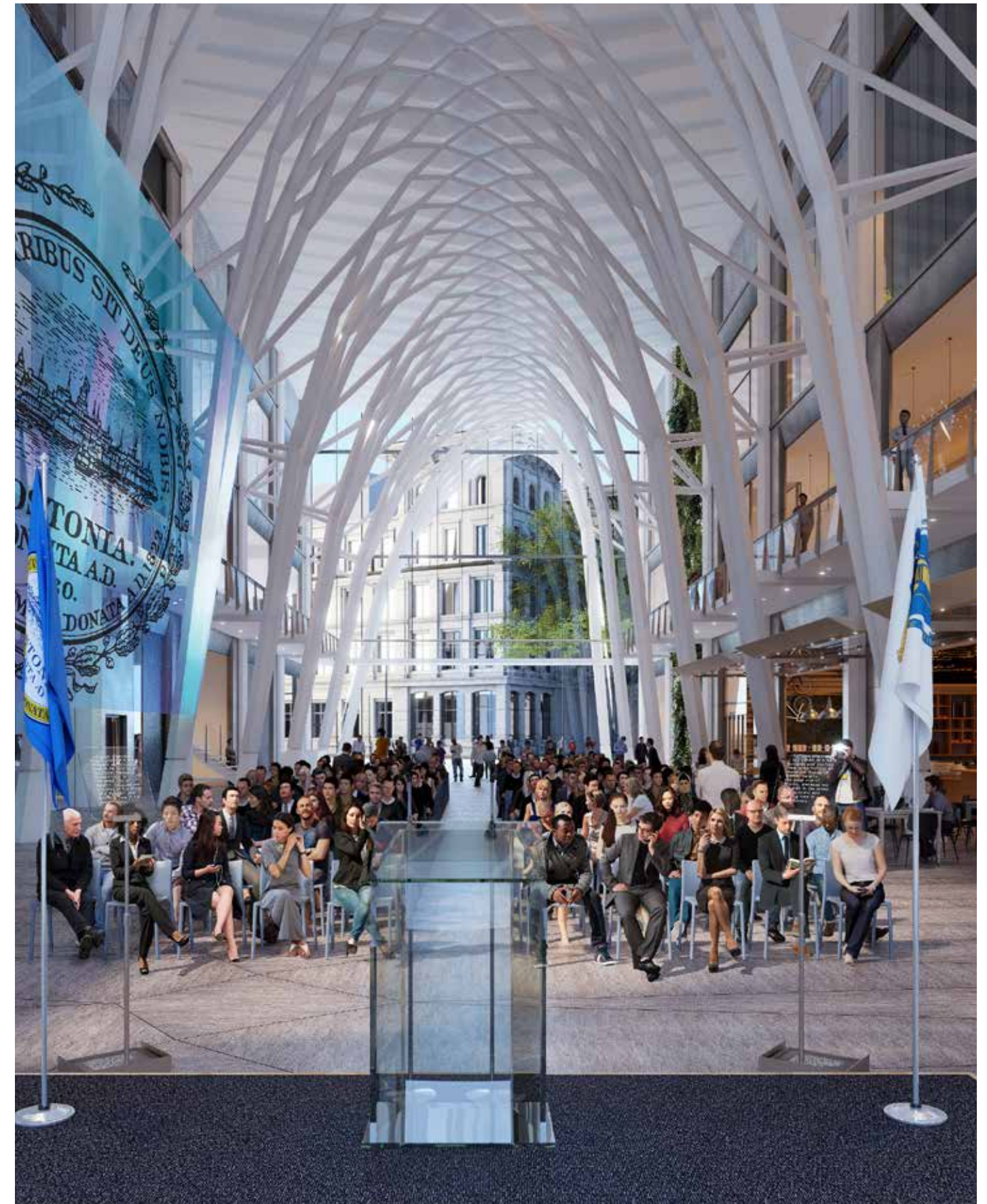

# Boston Fashion Week

JANUARY  
FEBRUARY  
**MARCH**  
APRIL  
MAY  
JUNE  
JULY  
AUGUST  
SEPTEMBER  
OCTOBER  
NOVEMBER  
DECEMBER

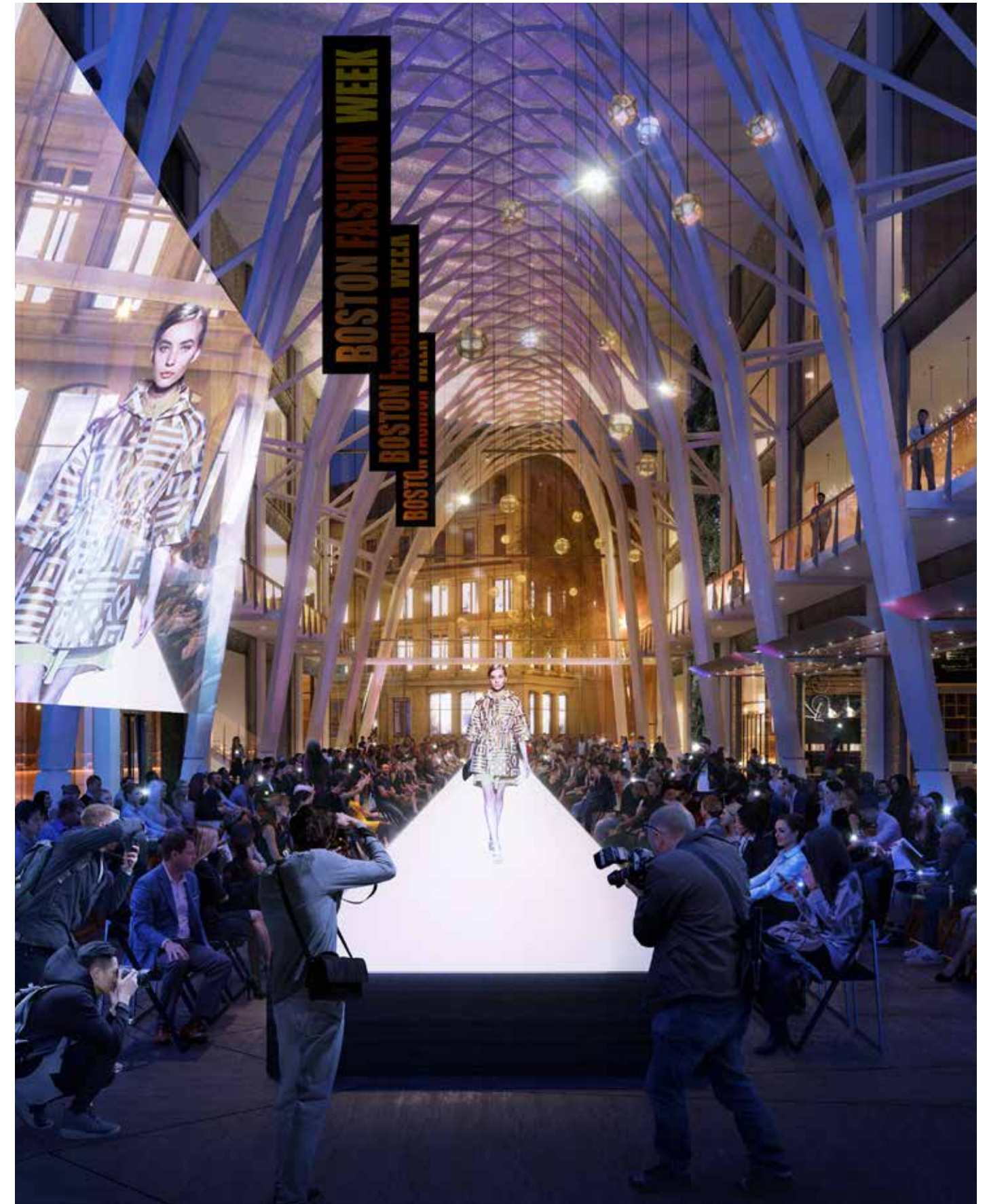



# City Market

JANUARY

FEBRUARY

MARCH

**APRIL**

**MAY**

**JUNE**

**JULY**

**AUGUST**

**SEPTEMBER**

**OCTOBER**

NOVEMBER

DECEMBER

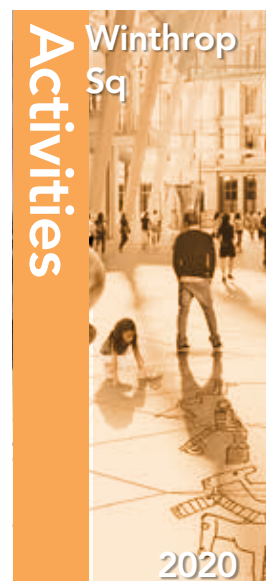

# Boston Art Fair

JANUARY  
FEBRUARY  
MARCH  
APRIL  
MAY  
**JUNE**  
JULY  
AUGUST  
SEPTEMBER  
OCTOBER  
NOVEMBER  
DECEMBER



## PROGRAMMING & ACTIVITY

115 WINTHROP SQUARE BCDC PNF FILING PRESENTATION

# City Music

JANUARY  
FEBRUARY  
MARCH  
APRIL  
MAY  
JUNE  
JULY  
AUGUST  
SEPTEMBER  
OCTOBER  
**NOVEMBER**  
DECEMBER

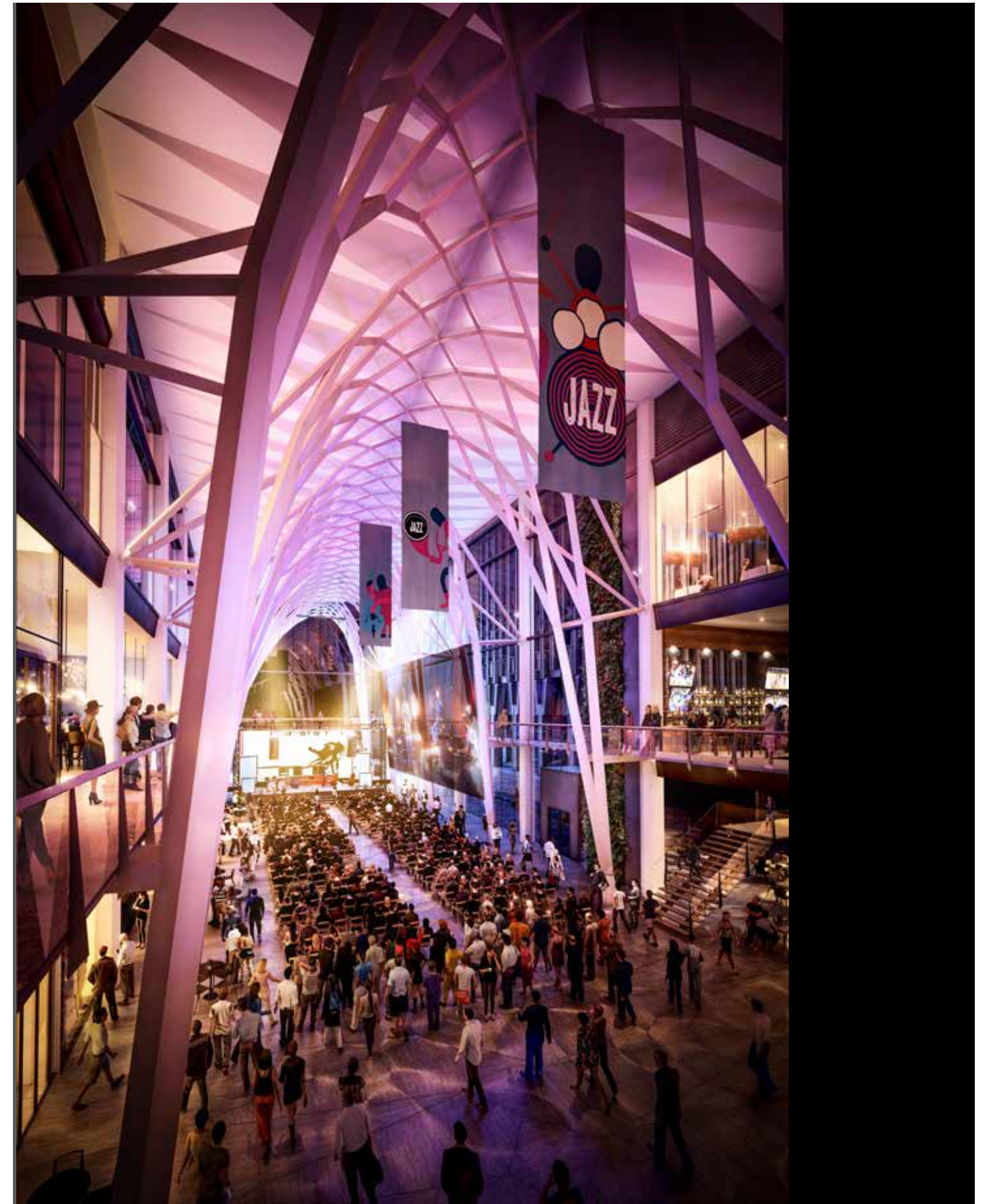

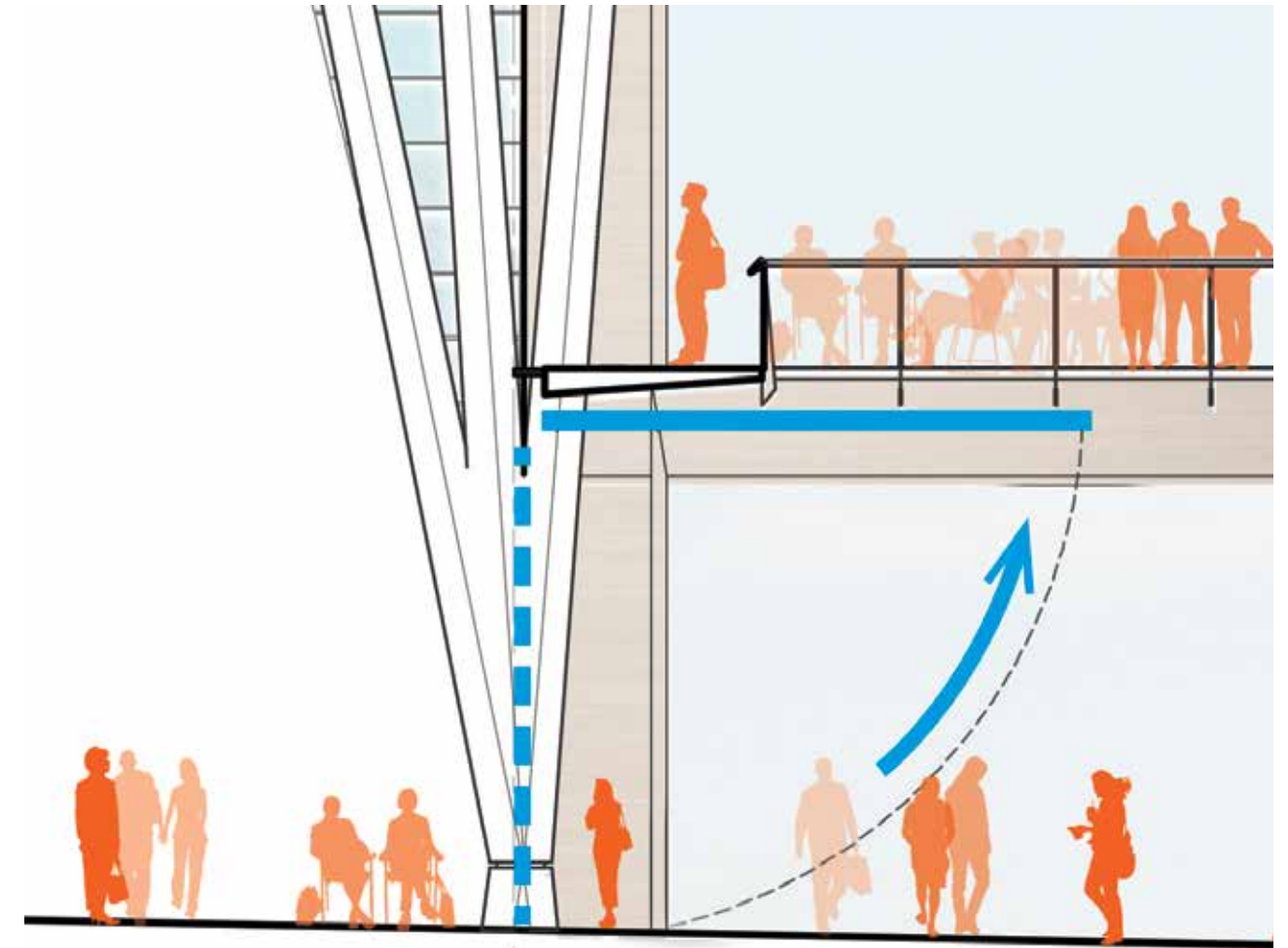

**OPEN FOR THE PUBLIC  
EVERYDAY**



ALL FIGURES & ILLUSTRATIONS APPROXIMATE AND SUBJECT TO CHANGE  
HANDEL ARCHITECTS, D/R/E/A/M COLLABORATIVE & GROUND FOR MILLENNIUM PARTNERS | 07 FEBRUARY 2017

VIEW FROM FEDERAL STREET  
115 WINTHROP SQUARE BCDC PNF FILING PRESENTATION



ALL FIGURES & ILLUSTRATIONS APPROXIMATE AND SUBJECT TO CHANGE

HANDEL ARCHITECTS, D/R/E/A/M COLLABORATIVE & GROUND FOR MILLENNIUM PARTNERS | 07 FEBRUARY 2017

## VIEW FROM WINTHROP SQUARE

115 WINTHROP SQUARE BCDC PNF FILING PRESENTATION

## Rebuilding the Outdoor Room



## Reconstituting Federal Street



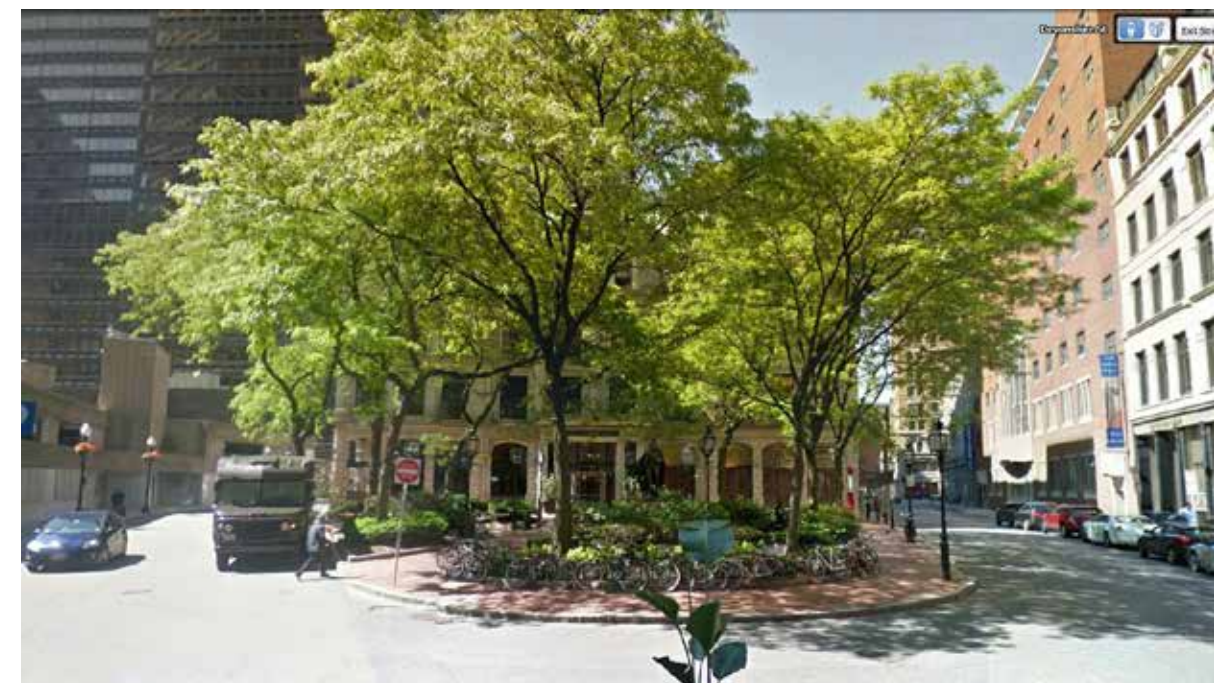
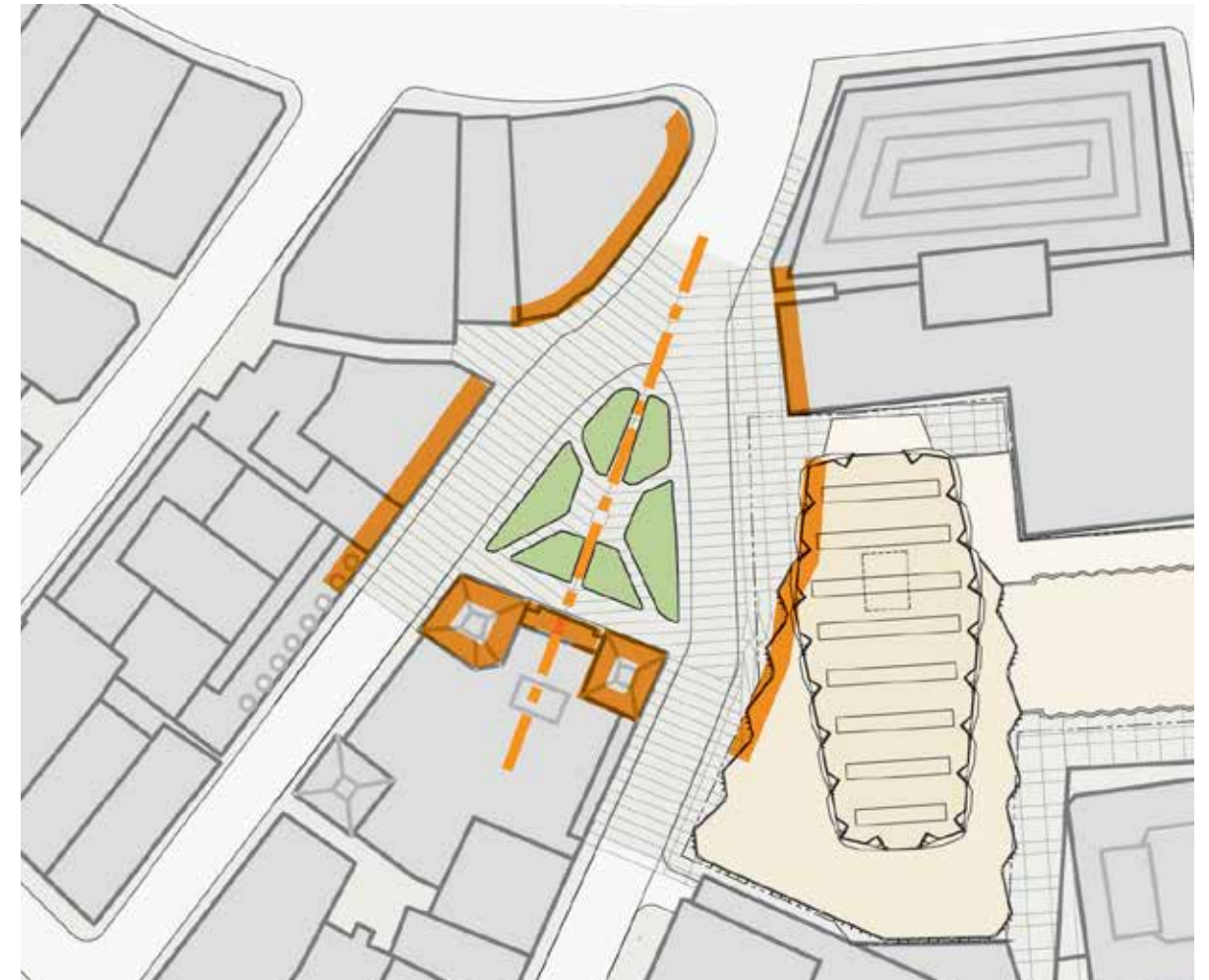
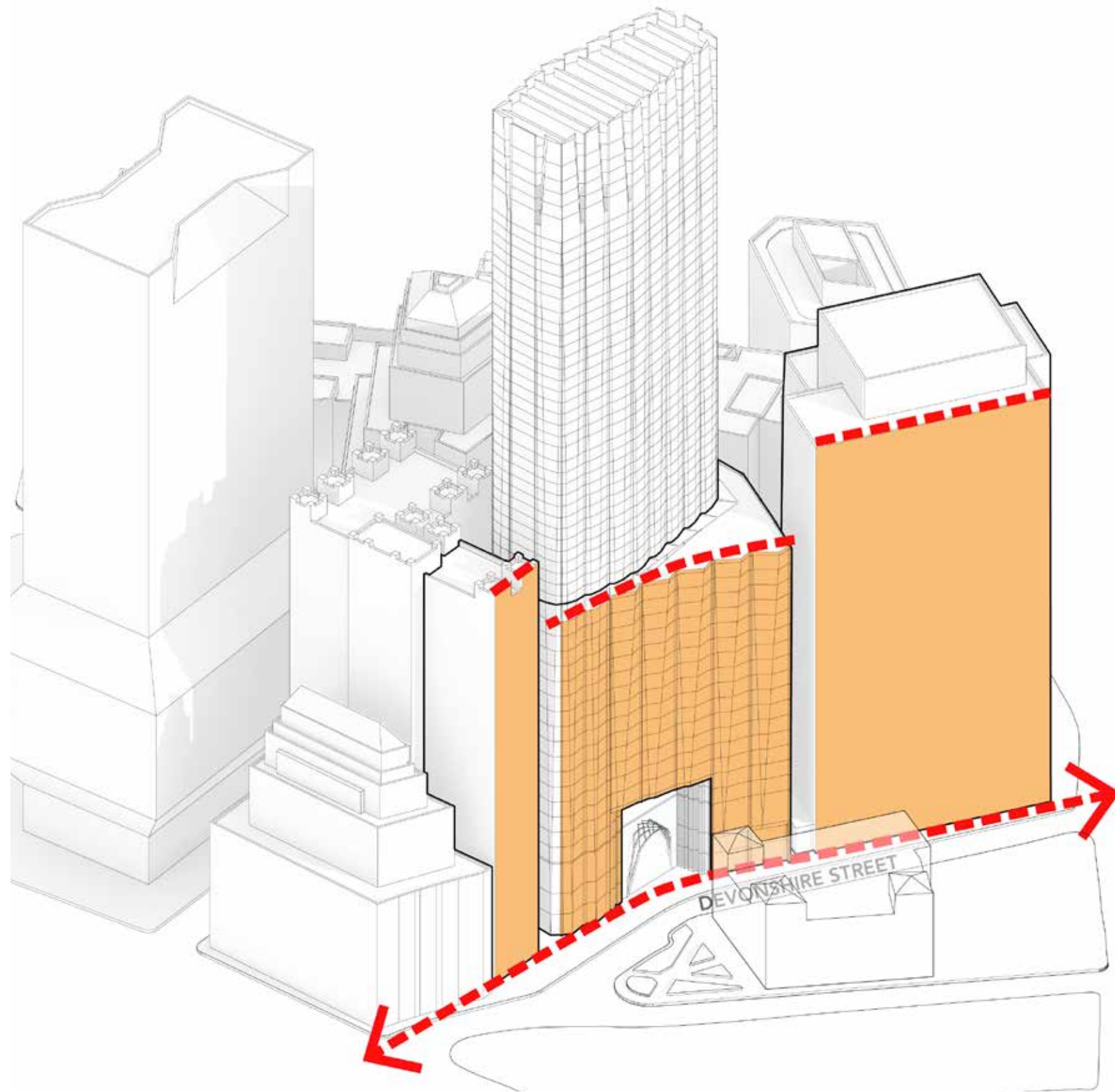



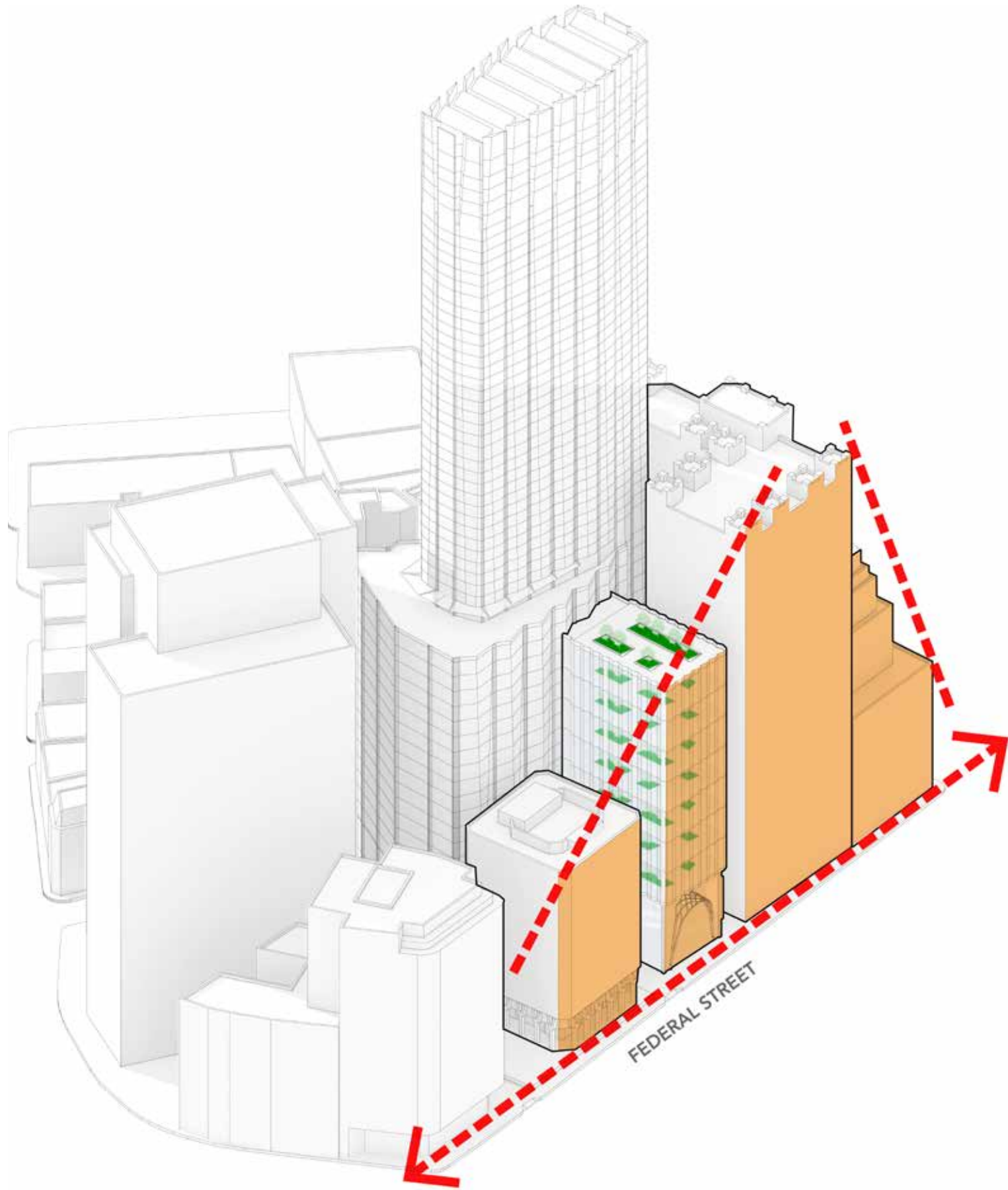

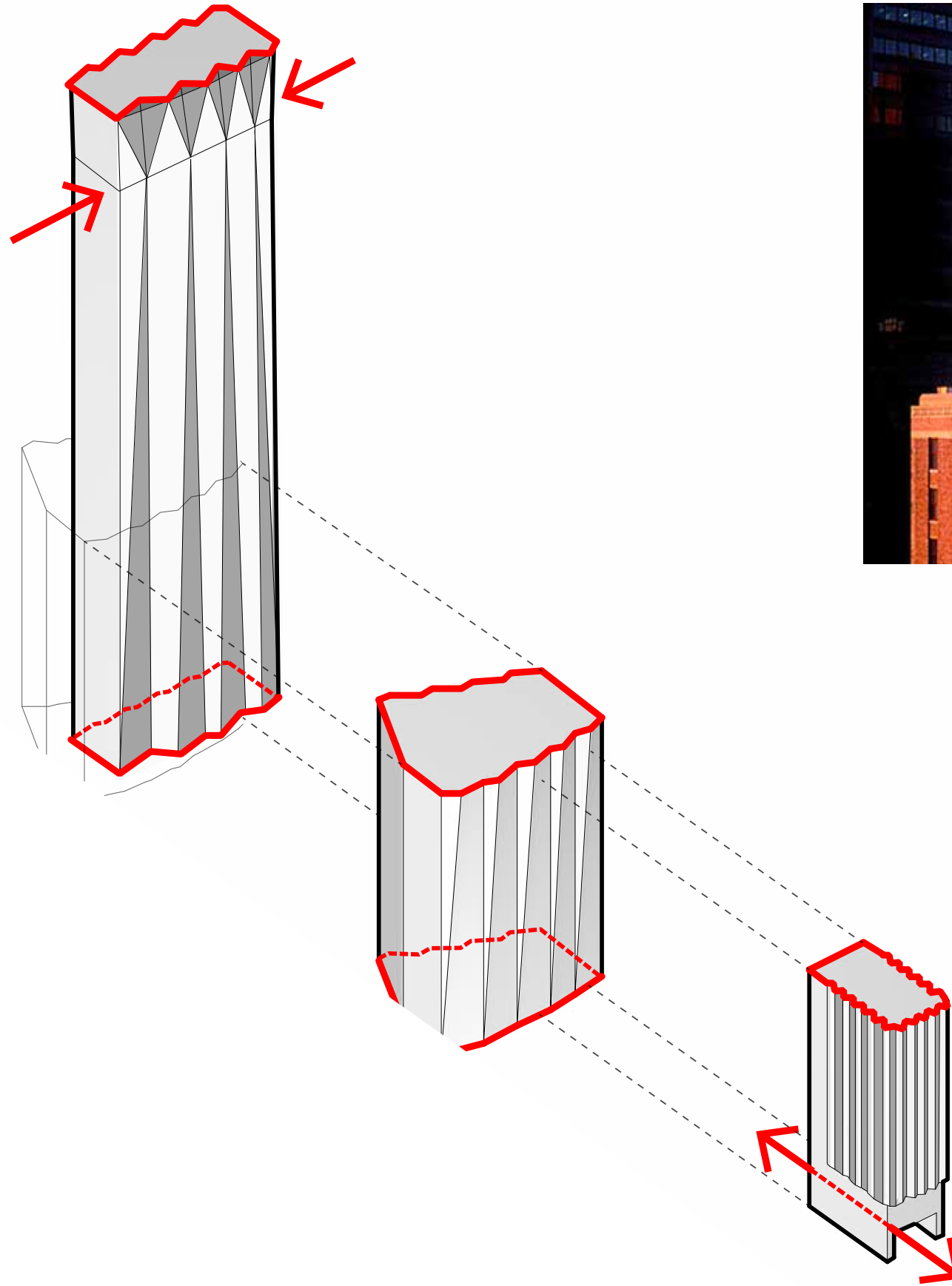

**1. Elemental**  
Tower + Podium + Bustle

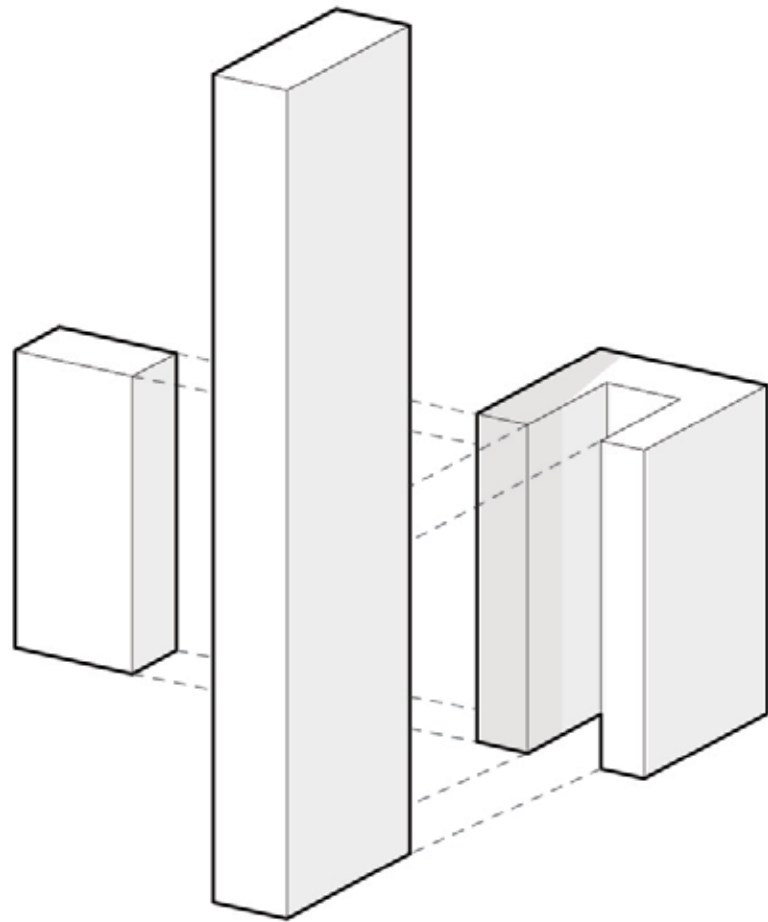

**2. Combination & Inflection**  
Response To Site

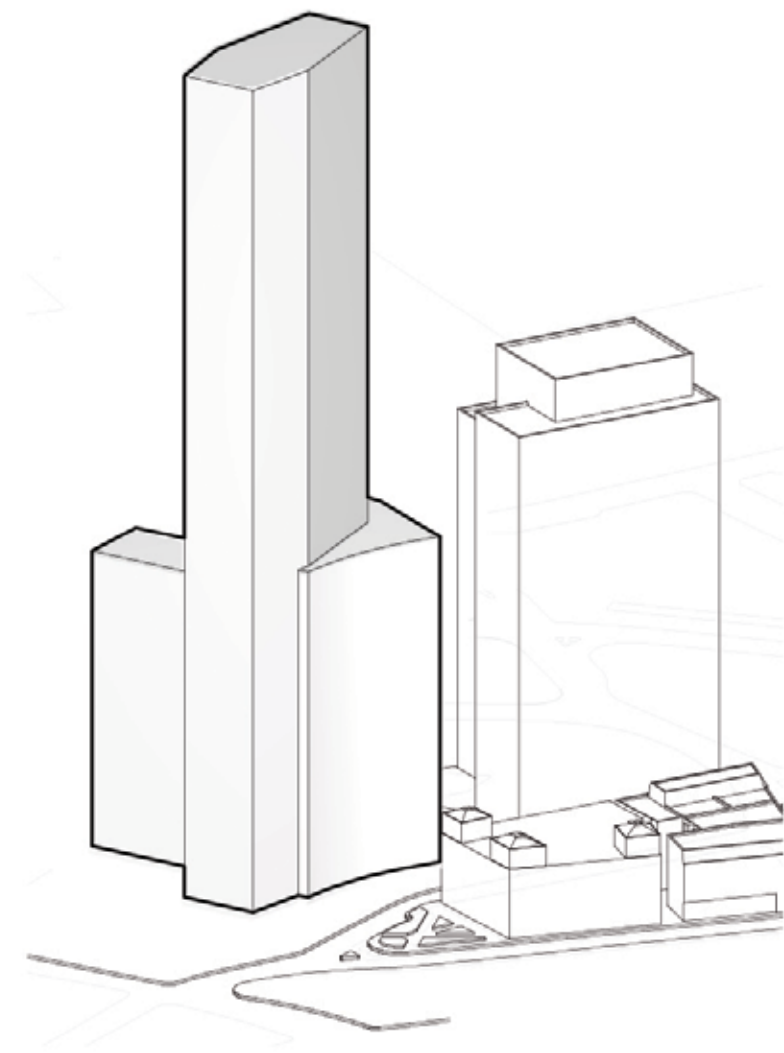

**3. Urban Connection**  
Part & Lift

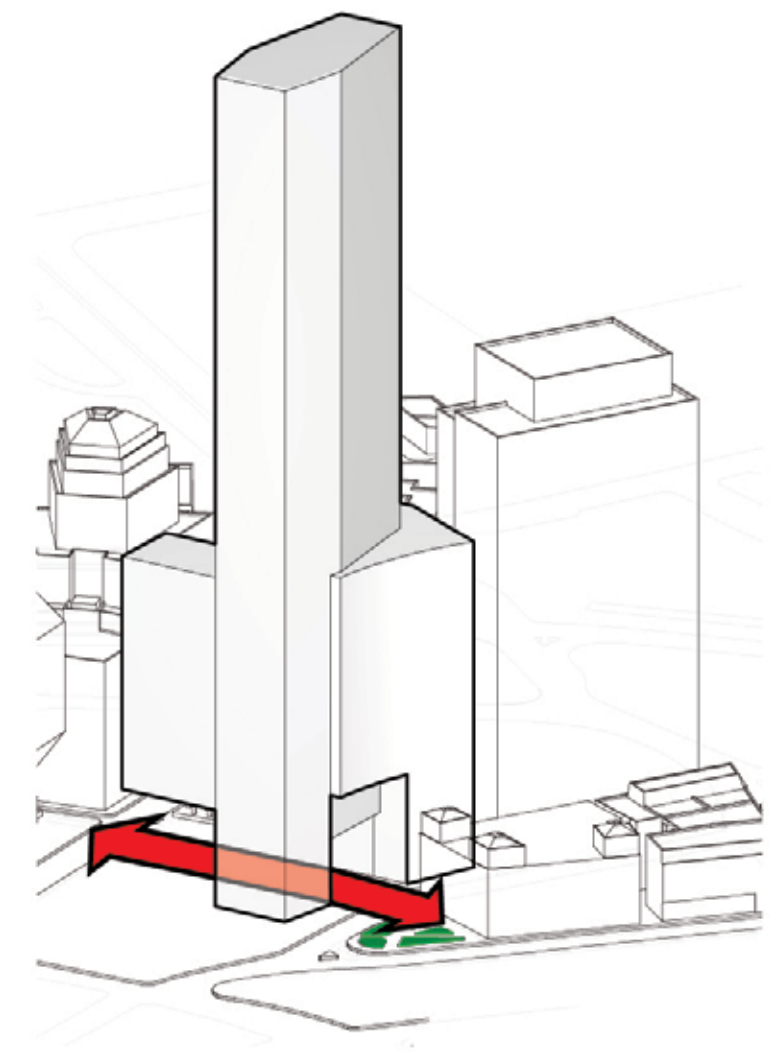

# The Great Hall and Mixed-Use Tower



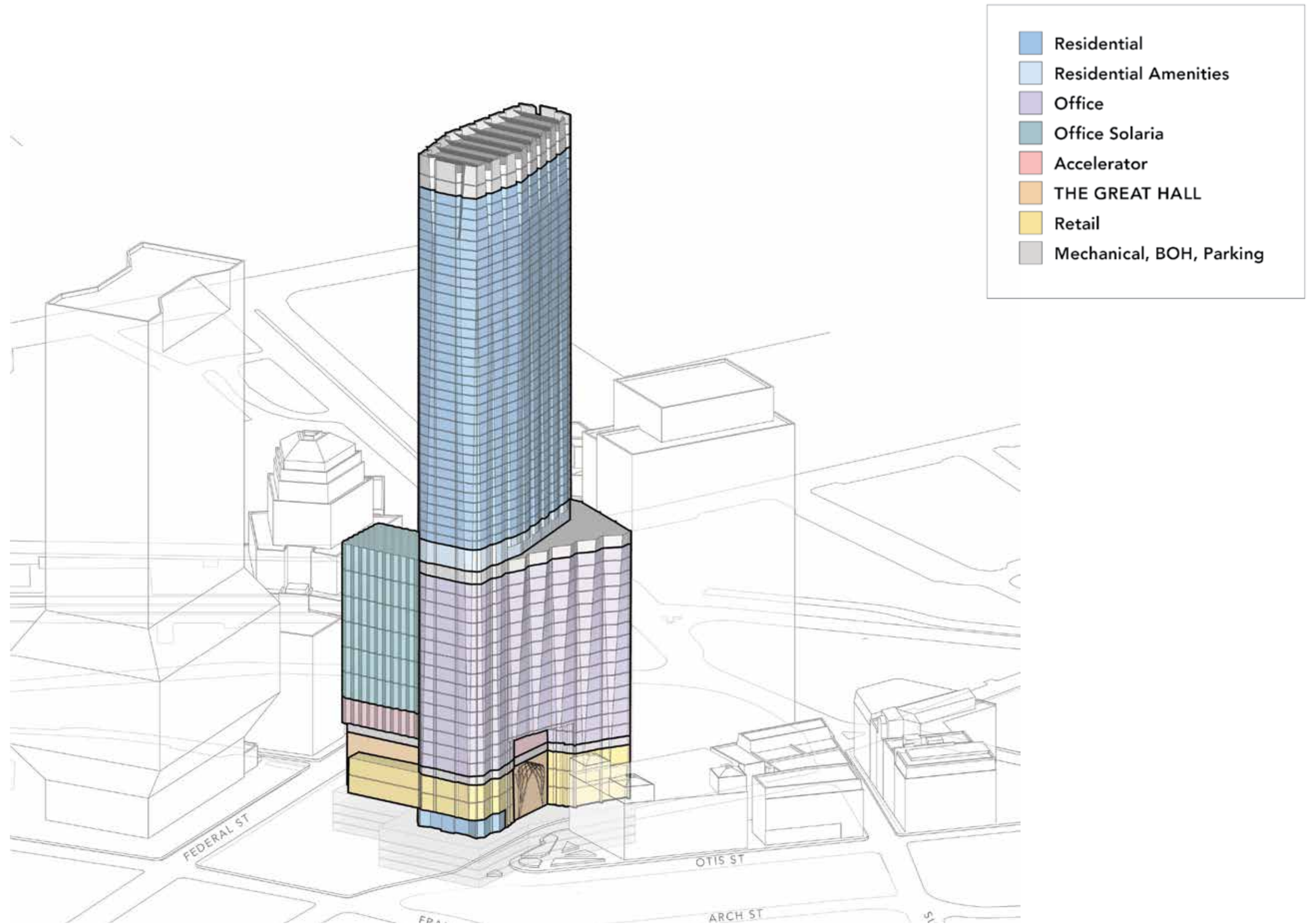

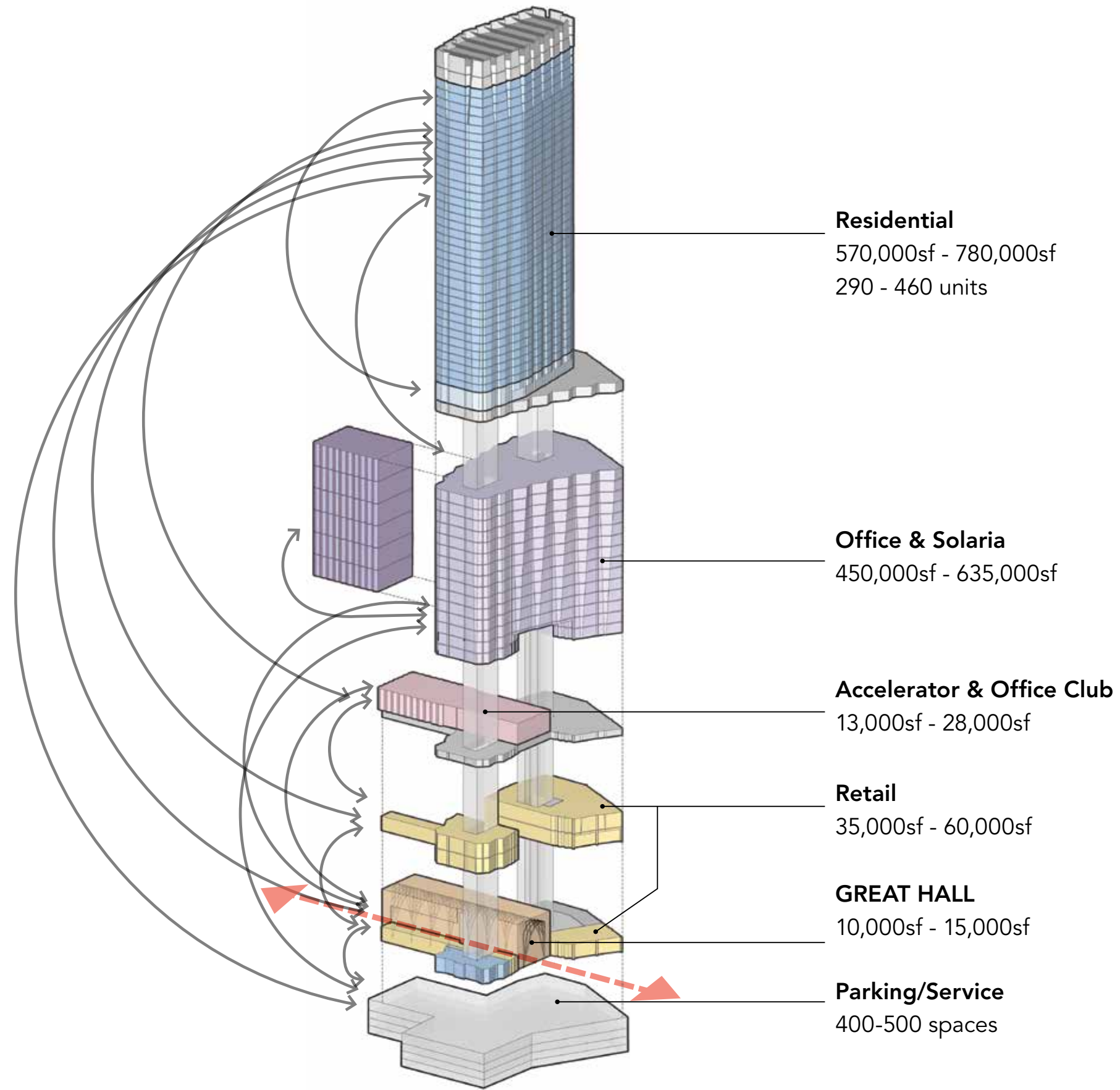

**Residential**  
 570,000sf - 780,000sf  
 290 - 460 units

**Office & Solaria**  
 450,000sf - 635,000sf

**Accelerator & Office Club**  
 13,000sf - 28,000sf

**Retail**  
 35,000sf - 60,000sf

**GREAT HALL**  
 10,000sf - 15,000sf

**Parking/Service**  
 400-500 spaces

**Total:**  
 Approximately  
 1,100,000sf-1,500,000sf

Typical Office Floor Plate



Typical Residential Floor Plate

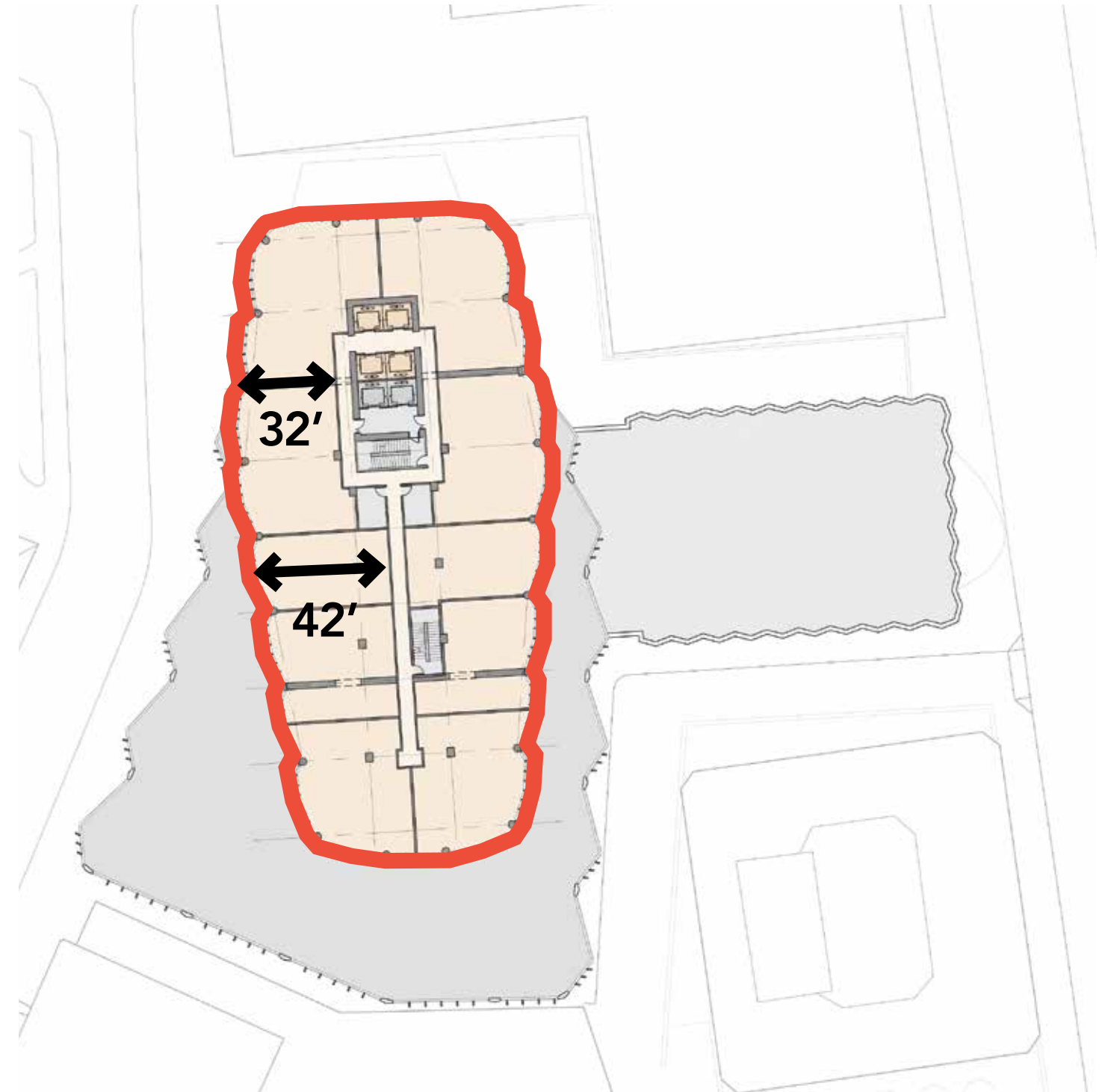

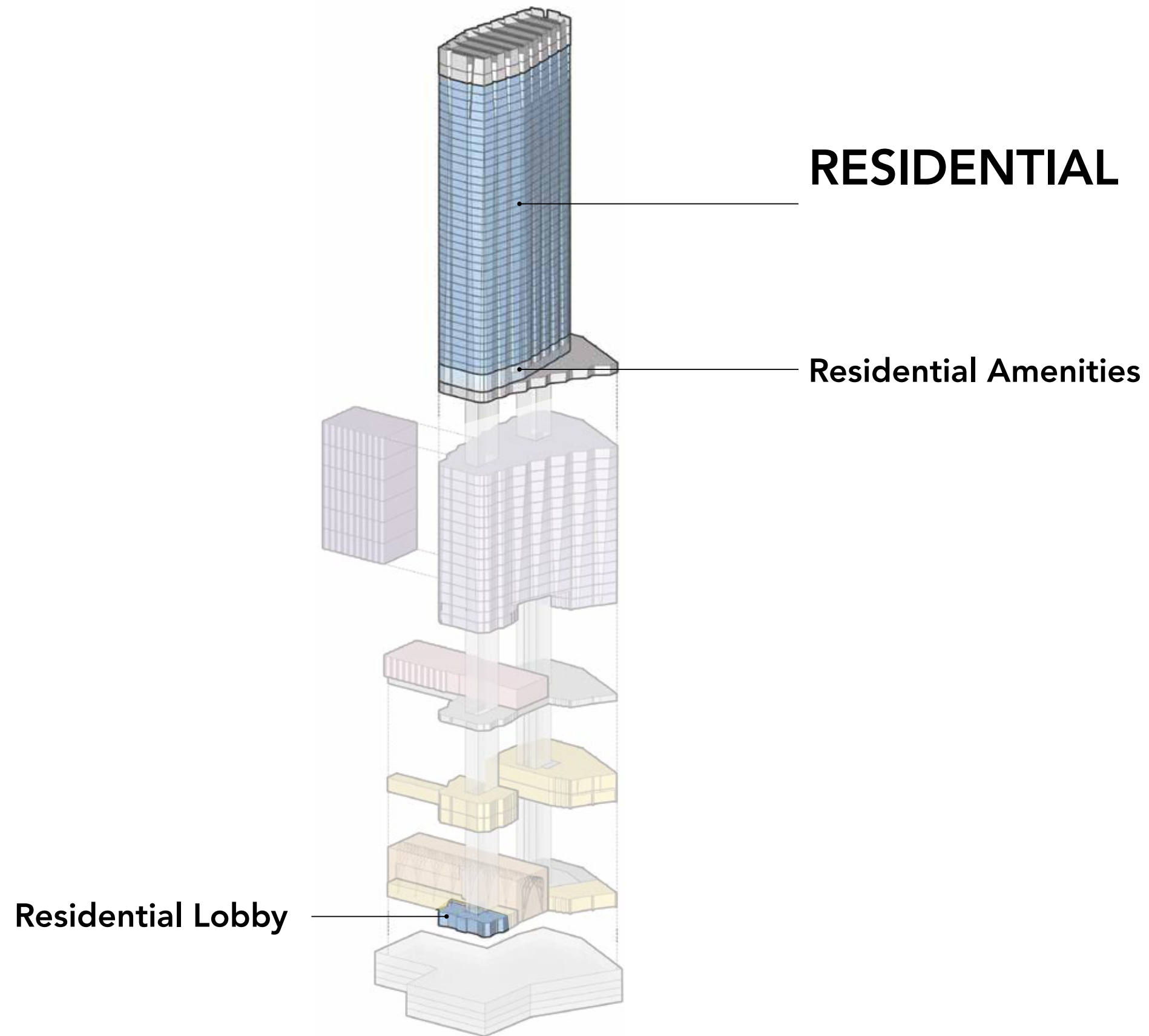





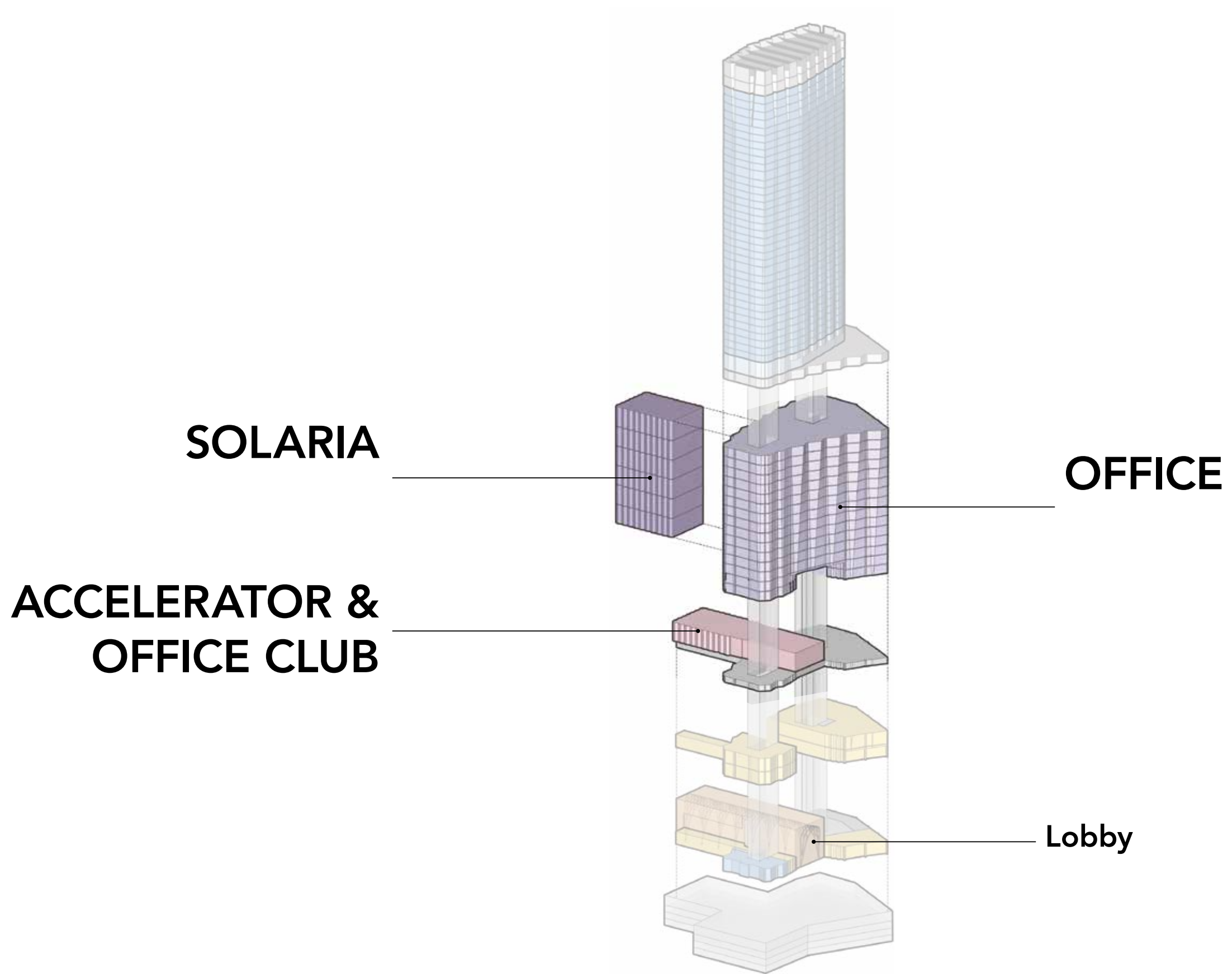



ACCELERATOR =  
Physical Space  
+ Community  
+ Access to Capital  
+ Mentorship  
+ Demo Days  
+ Business Services  
+ Skill Set Training



- Non Hierarchical
- Collaborative
- Flexible
- Open
- The "Third Space"
- Building Wide Amenities





ALL FIGURES & ILLUSTRATIONS APPROXIMATE AND SUBJECT TO CHANGE  
HANDEL ARCHITECTS, D/R/E/A/M COLLABORATIVE & GROUND FOR MILLENNIUM PARTNERS | 07 FEBRUARY 2017

**THE CHANGING WORKPLACE**  
115 WINTHROP SQUARE BCDC PNF FILING PRESENTATION



- Double Height
- Indoor / Outdoor
- Functions as a gathering space, communal space, collaboration space
- Provides a connection to nature







# LEED PLATINUM



Energy Efficient Residences



High Performance Exterior Wall



Healthy Interior Environment



Resiliency



PV Array

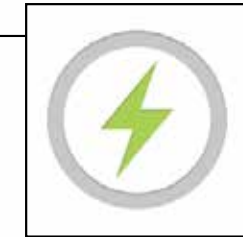

Energy Efficient Building Systems



Green Roof



## OFFICE: PASSIVE HOUSE



Healthy Interior Environment

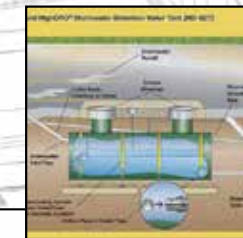

Water Management

Source Energy

**Standard**  
148k BTU/ft<sup>2</sup>



**LEED Gold**

90k BTU/ft<sup>2</sup>  
40%  
Energy Reduction



**LEED Platinum**

74k BTU/ft<sup>2</sup>  
50%  
Energy Reduction



**Passive House**

38k BTU/ft<sup>2</sup>  
75%  
Energy Reduction



- Exceeds City of Boston's 2020 carbon reduction goals

## WHY PASSIVE HOUSE?



### Superior Working Environment

- Improve indoor air quality and comfort
- Provide acoustic separation from the surrounding environment
- Increase resiliency of building components



### Most Rigorous Energy Efficiency Standard in the World

- Most effective way to reduce energy consumption
- Combats climate change by drastically reducing greenhouse gas emissions
- Reduce dependence on fossil fuels
- Passive House is a direct response to stopping global warming
- Reduce strain on city infrastructure
- Improve resiliency

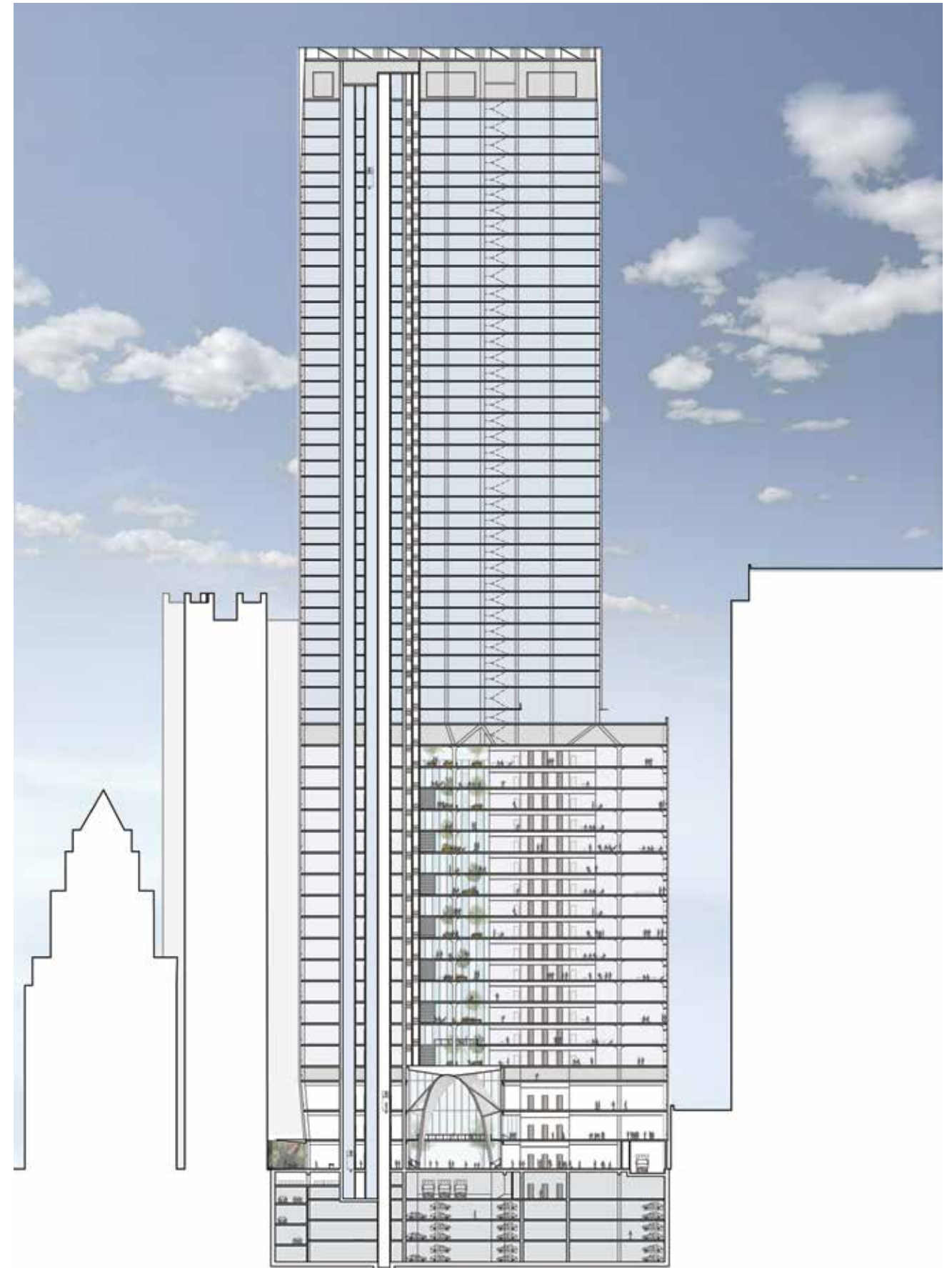



- 1 The Great Hall
- 2 Retail / food & beverage
- 3 Residential lobby
- 4 Office lobby
- 5 BOH
- 6 Service & non-resident parking access
- 7 Residential porte-cochère

ALL FIGURES & ILLUSTRATIONS APPROXIMATE AND SUBJECT TO CHANGE

HANDEL ARCHITECTS, D/R/E/A/M COLLABORATIVE & GROUND FOR MILLENNIUM PARTNERS | 07 FEBRUARY 2017

# GROUND FLOOR PLAN

115 WINTHROP SQUARE BCDC PNF FILING PRESENTATION

## B1 LEVEL

- 1 Loading
- 2 Access to parking below
- 3 Office bicycle facilities
- 4 Residential bicycle facilities (on mezzanine)
- 5 BOH/MECH
- 6 Recycling
- 7 Utilities

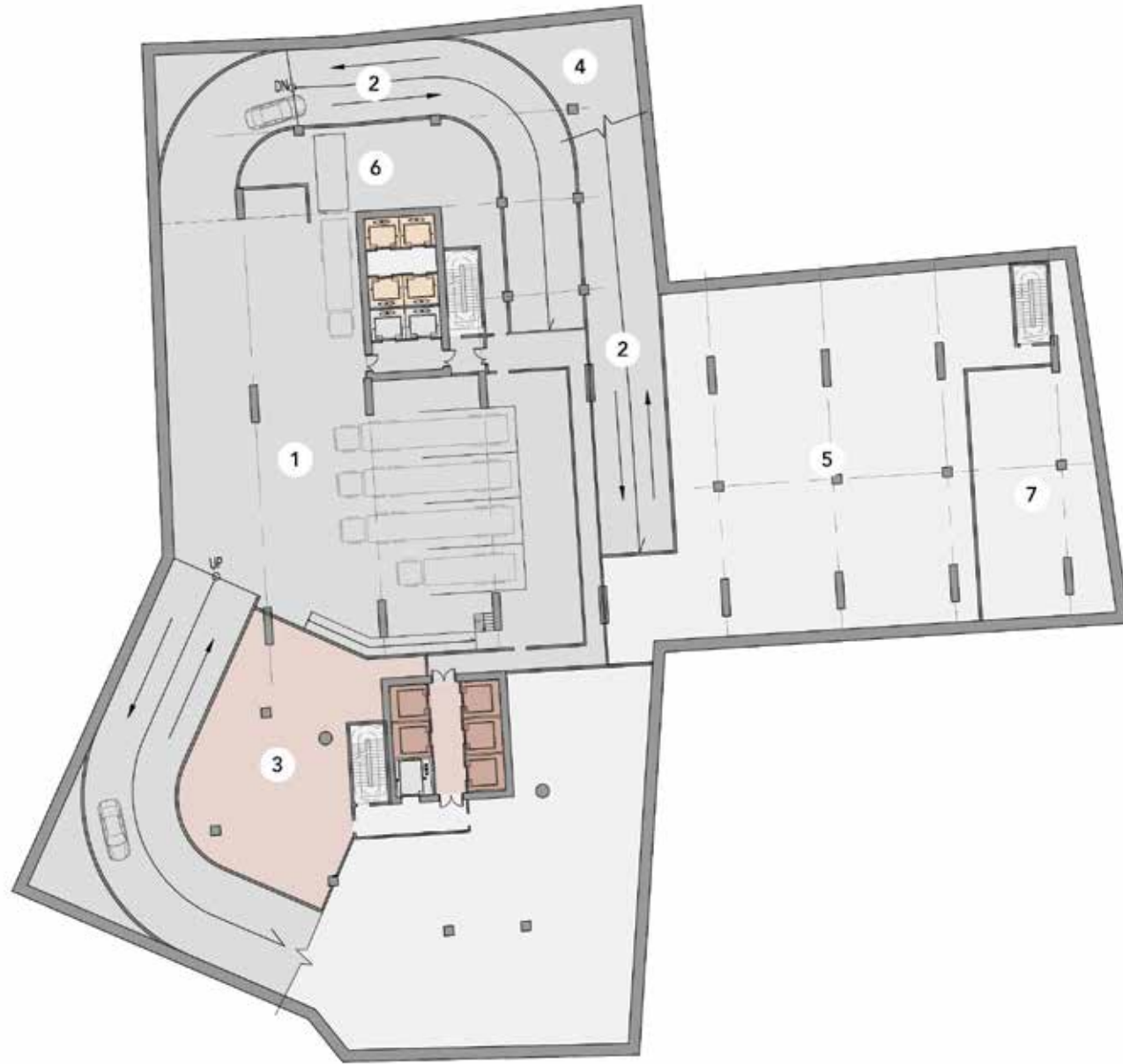

## B2/B3/B4 LEVELS

- 1 Parking (Residents, non-residents, cars electric)
- 2 BOH

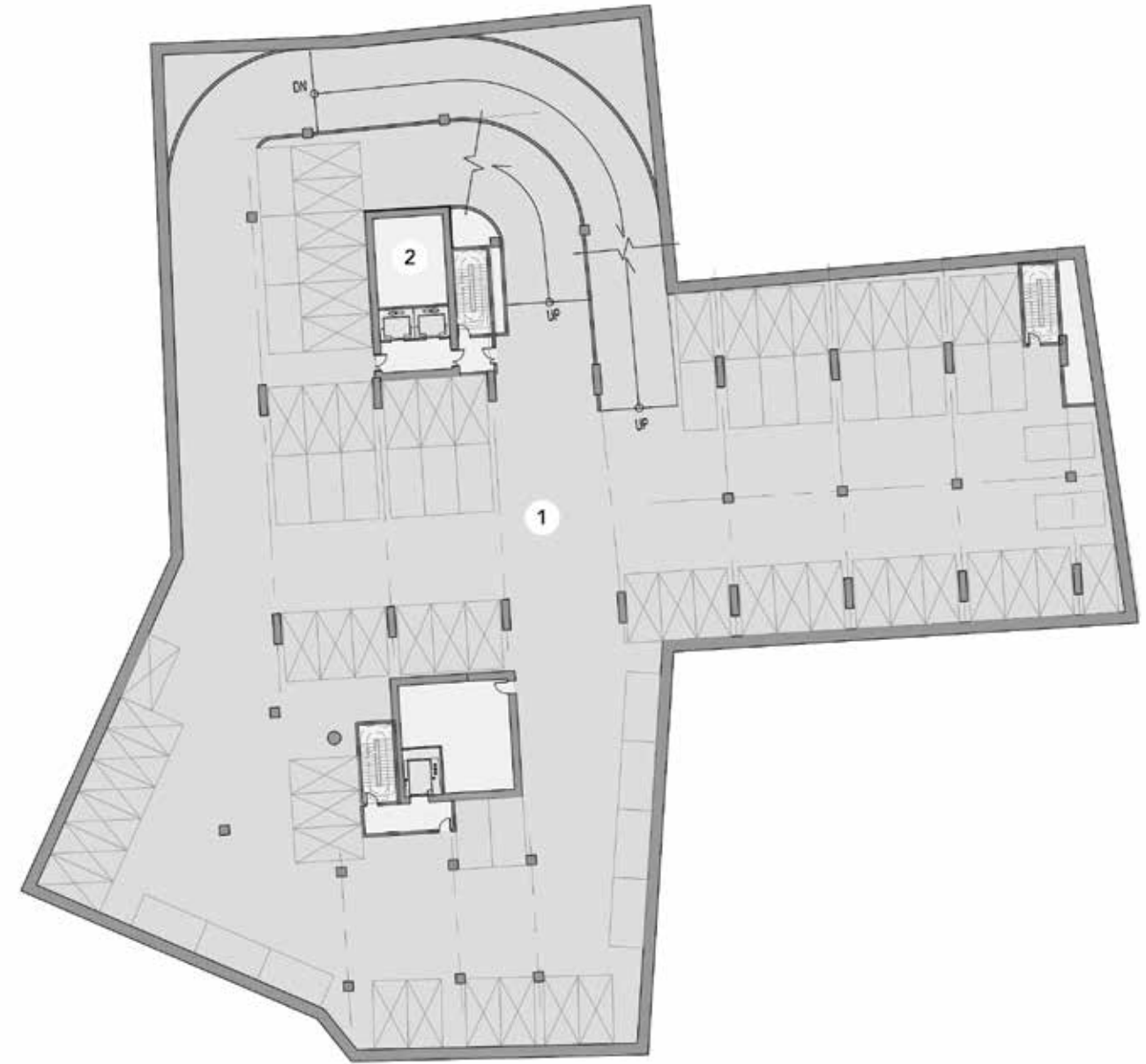

## 2ND LEVEL

- 1 The Great Hall (Open to below)
- 2 Retail / food & beverage
- 3 Common food & beverage facilities

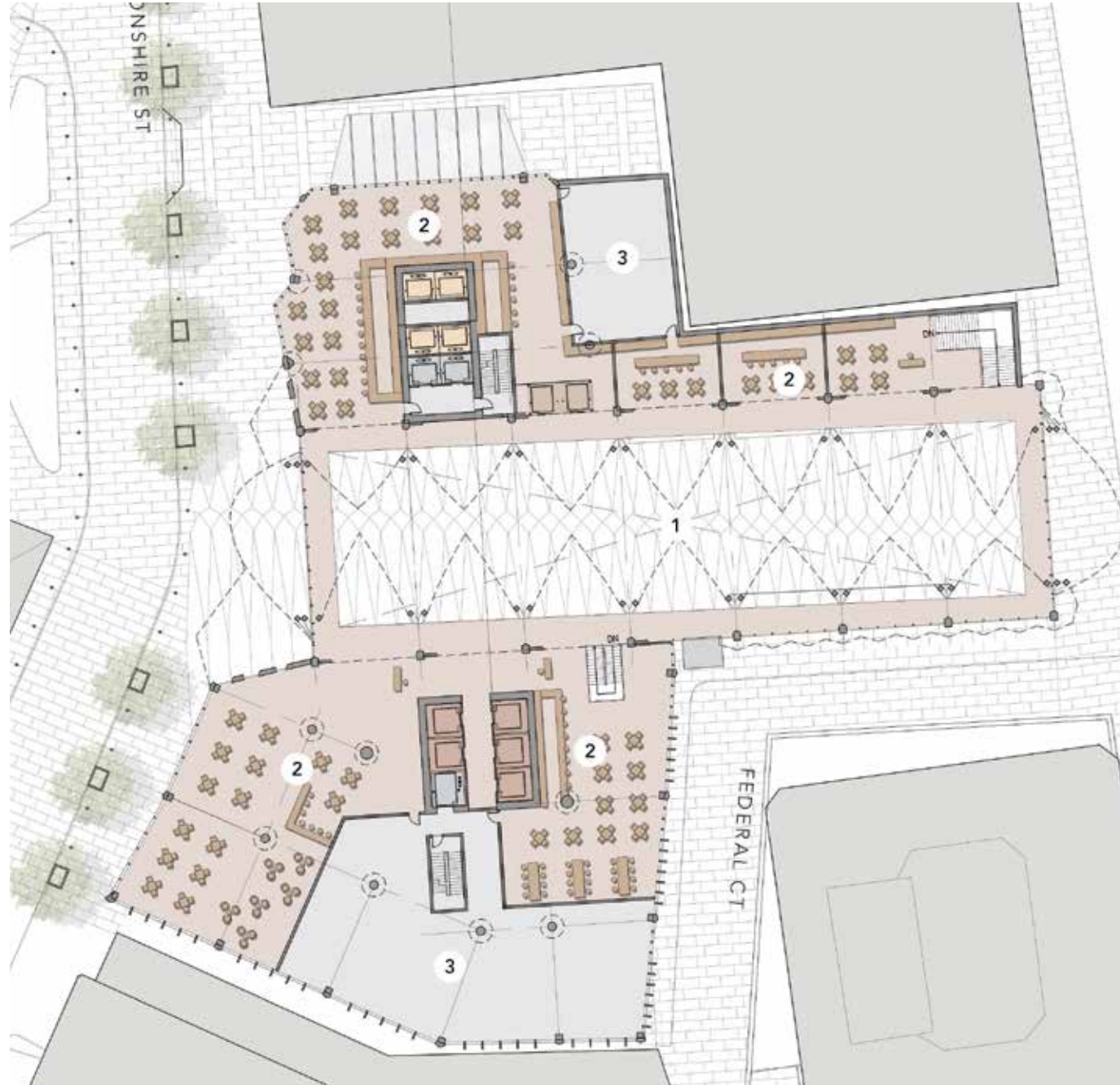

## 3RD LEVEL

- 1 Accelerator
- 2 Office Club
- 3 BOH

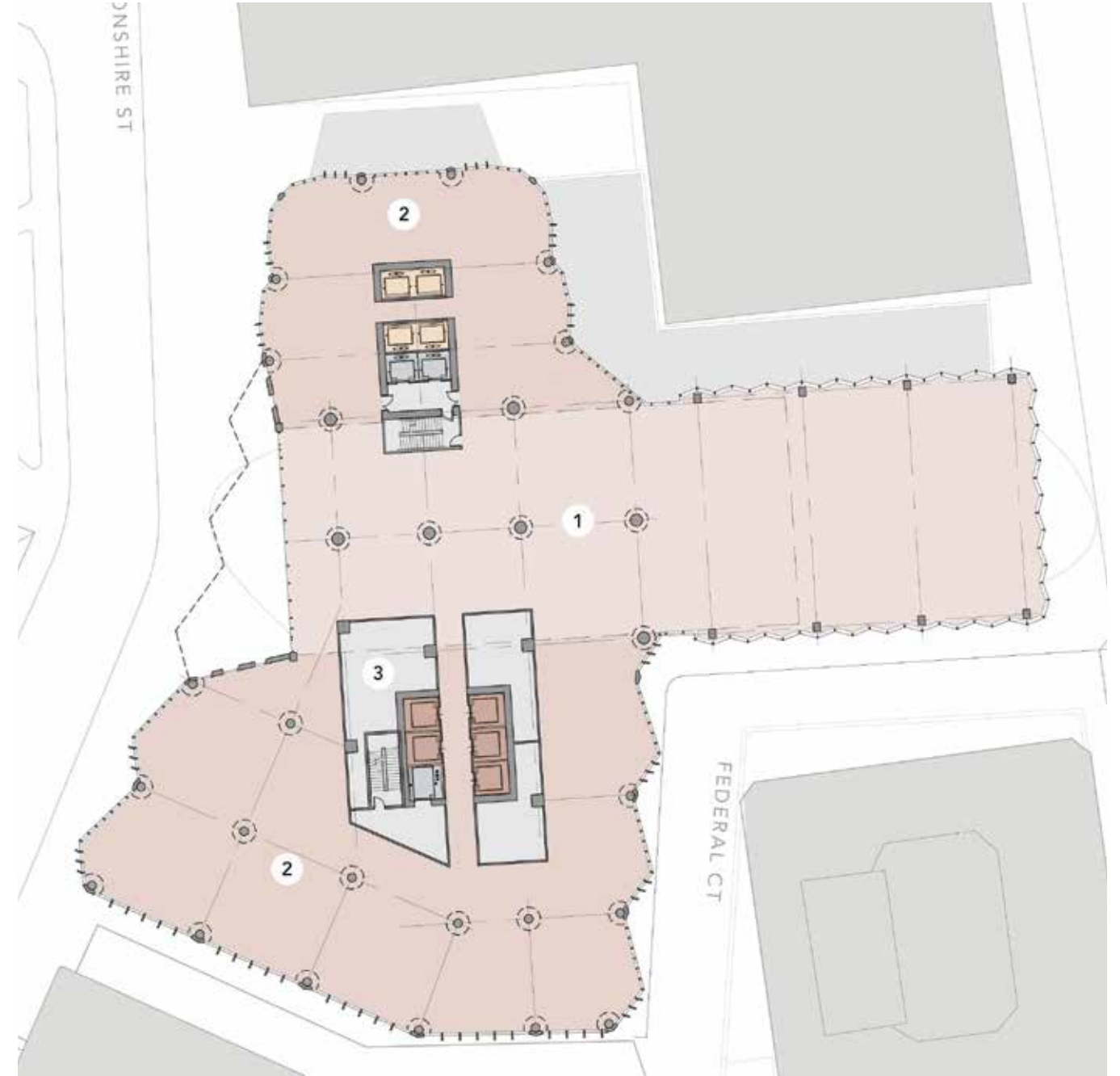

# TYPICAL OFFICE LEVEL

- 1 Office
- 2 Office Solaria
- 3 BOH



## RESIDENTIAL AMENITY LEVEL

- 1 Residential Club
- 2 Roof terrace for residences



## TYPICAL RESIDENTIAL LEVEL

- 1 Residences

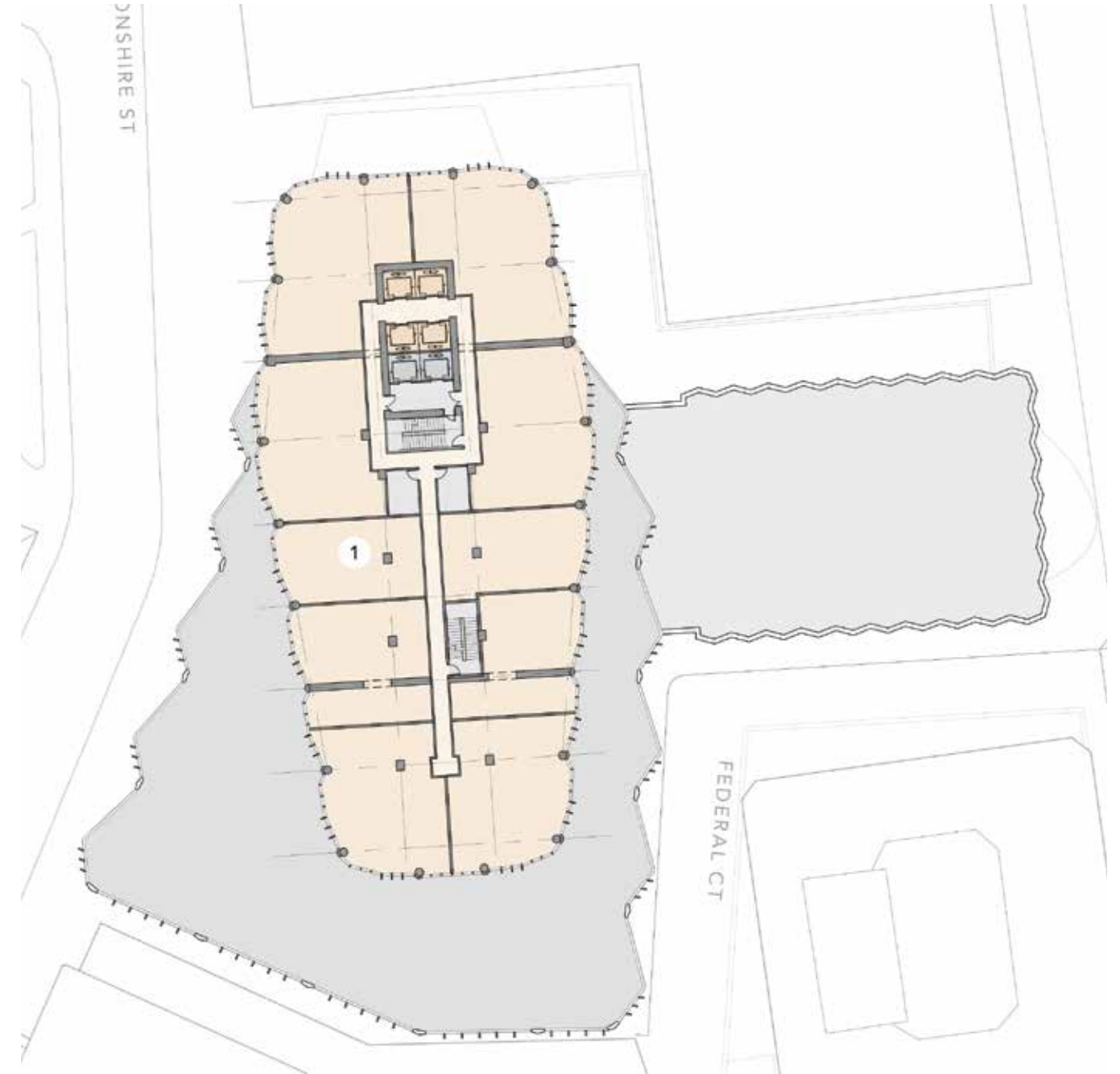





ALL FIGURES & ILLUSTRATIONS APPROXIMATE AND SUBJECT TO CHANGE

HANDEL ARCHITECTS, D/R/E/A/M COLLABORATIVE & GROUND FOR MILLENNIUM PARTNERS | 07 FEBRUARY 2017

## VIEW FROM WINTHROP SQUARE

115 WINTHROP SQUARE BCDC PNF FILING PRESENTATION



ALL FIGURES & ILLUSTRATIONS APPROXIMATE AND SUBJECT TO CHANGE  
HANDEL ARCHITECTS, D/R/E/A/M COLLABORATIVE & GROUND FOR MILLENNIUM PARTNERS | 07 FEBRUARY 2017

**AN ICON FOR DOWNTOWN**  
115 WINTHROP SQUARE BCDC PNF FILING PRESENTATION



ALL FIGURES & ILLUSTRATIONS APPROXIMATE AND SUBJECT TO CHANGE  
HANDEL ARCHITECTS, D/R/E/A/M COLLABORATIVE & GROUND FOR MILLENNIUM PARTNERS | 07 FEBRUARY 2017

**VIEW TO THE WEST**  
115 WINTHROP SQUARE BCDC PNF FILING PRESENTATION