

One Kenmore Square

BCDC Meeting

July 2nd, 2019

Owner : Mark Development

Urban Design : Speck & Associates

Traffic Planning : Stantec

Wind Testing : RWDI

Architect : Studio Gang

Landscape Architect : Reed Hilderbrand



WHAT WE HEARD

Is the building location precisely fixed?

More like an island than the heart of a square?

Clarify pedestrian and vehicle circulation benefits?

Looking
west down
Commonwealth
Avenue



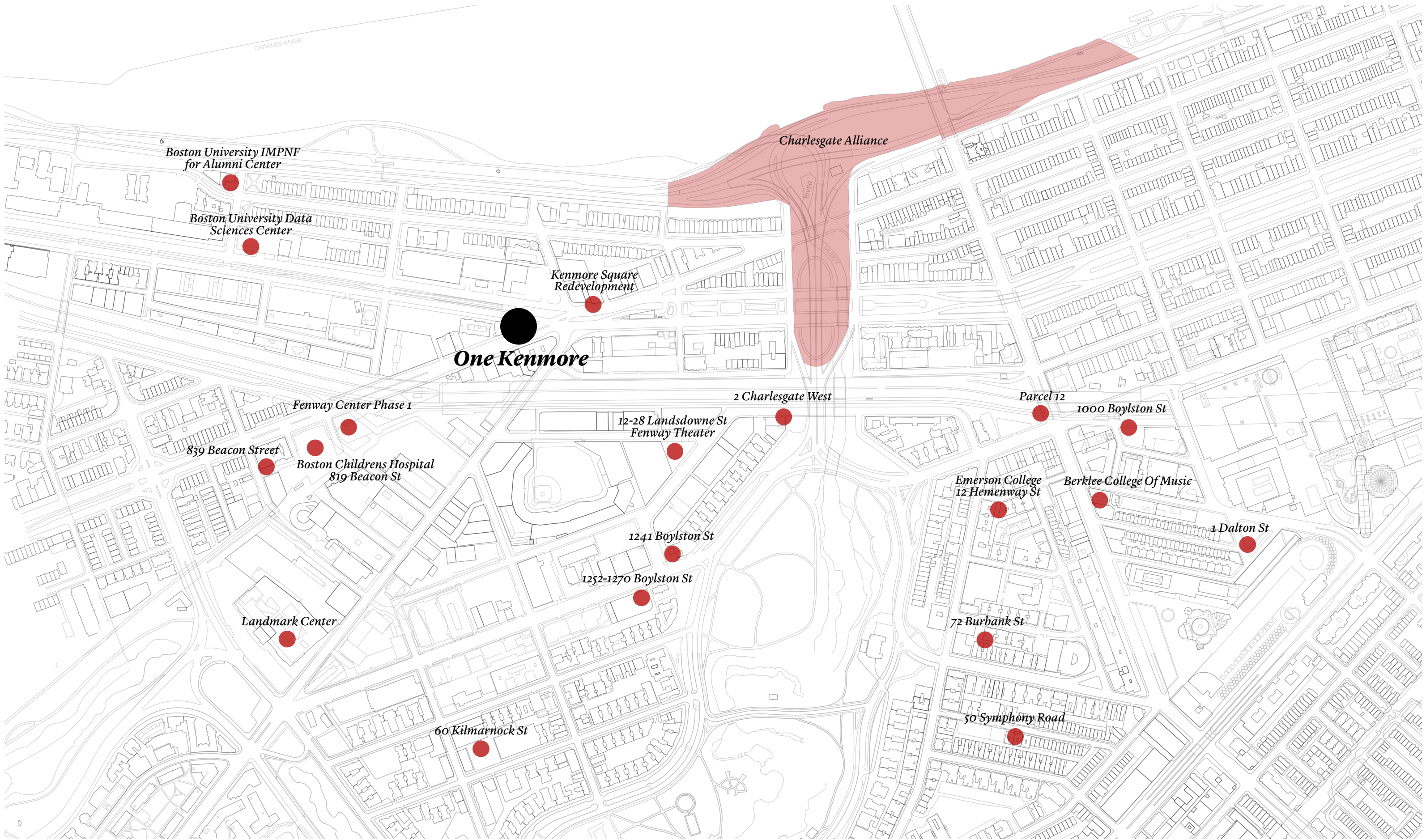

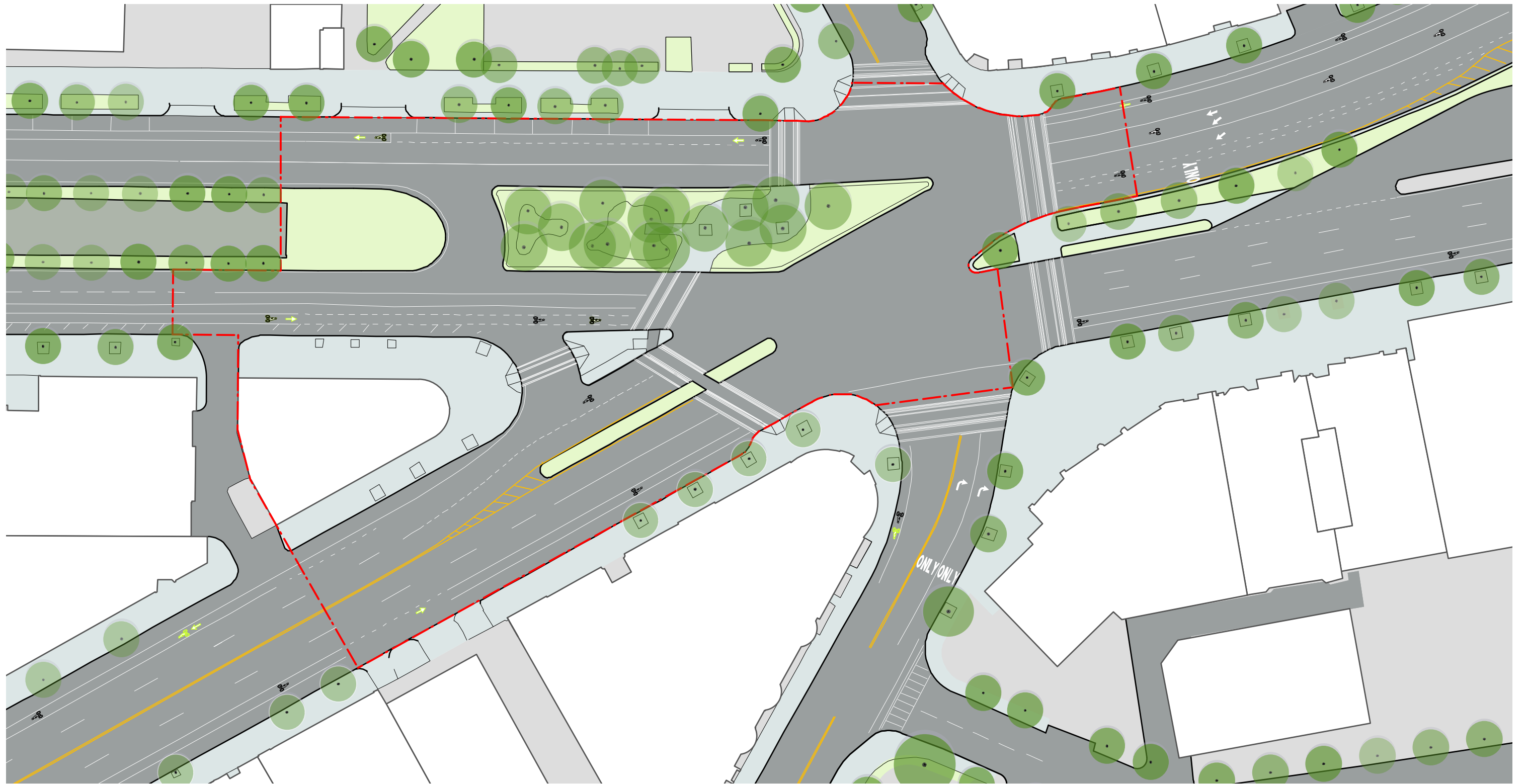

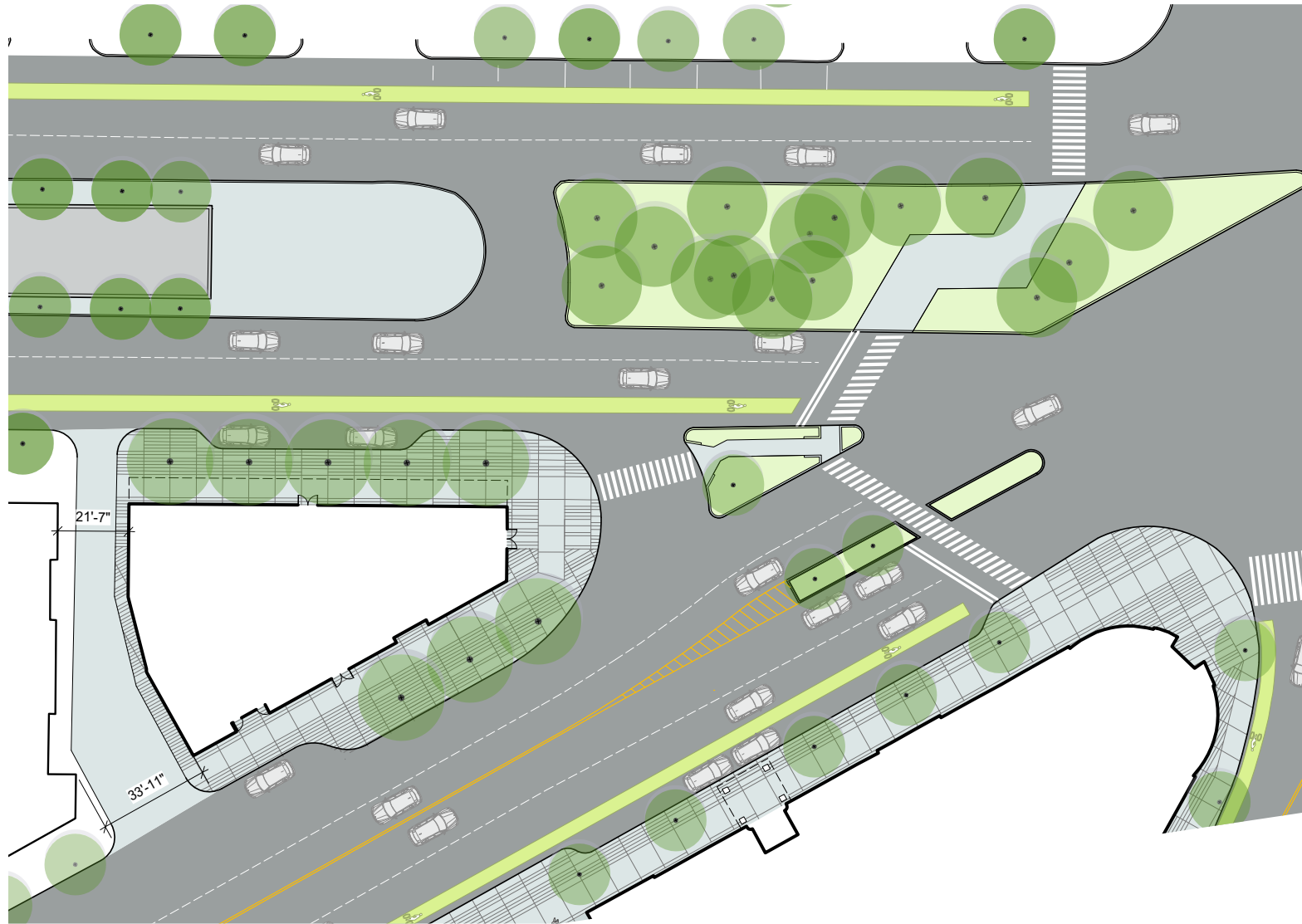

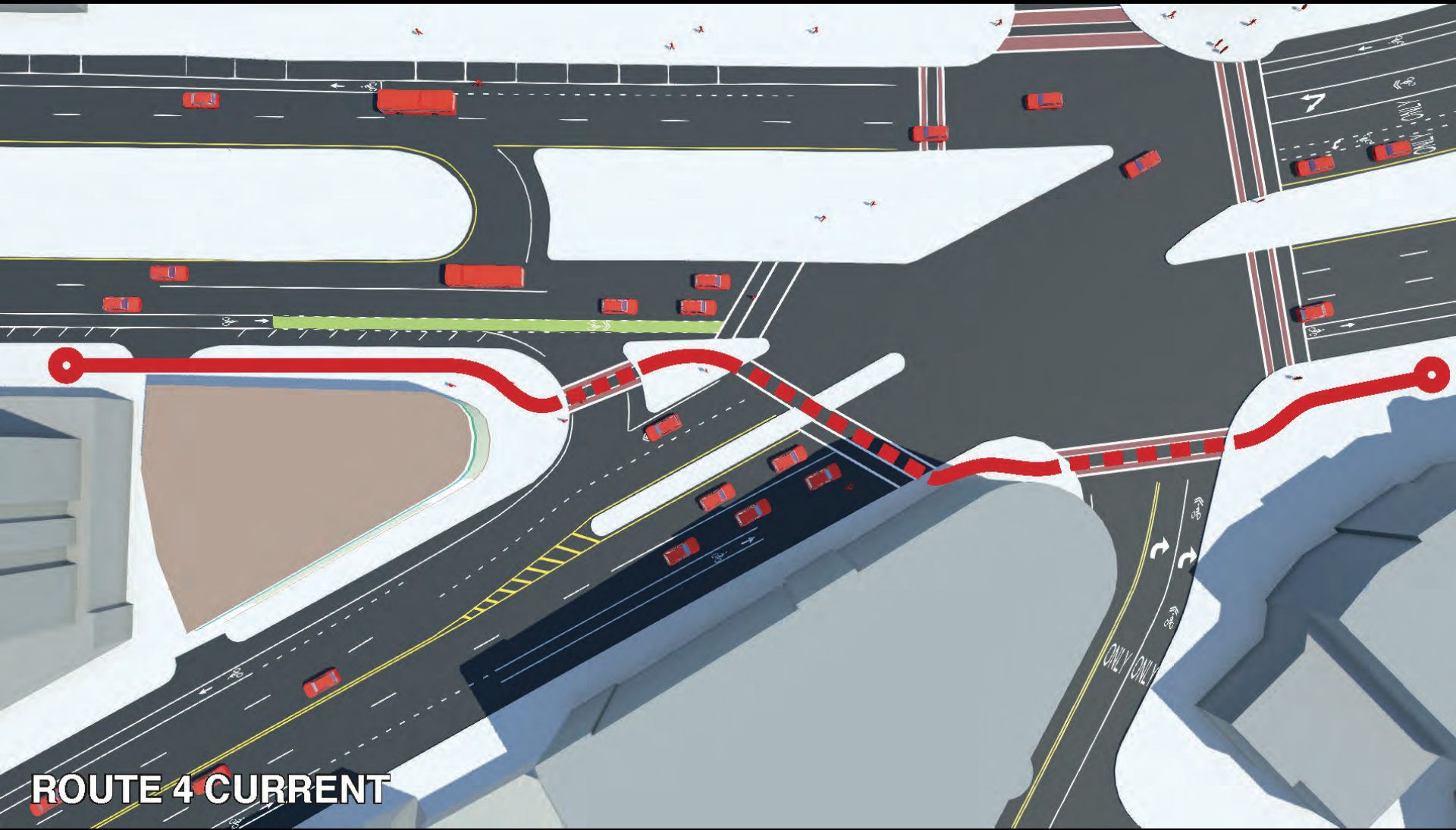

ROUTE 4 CURRENT

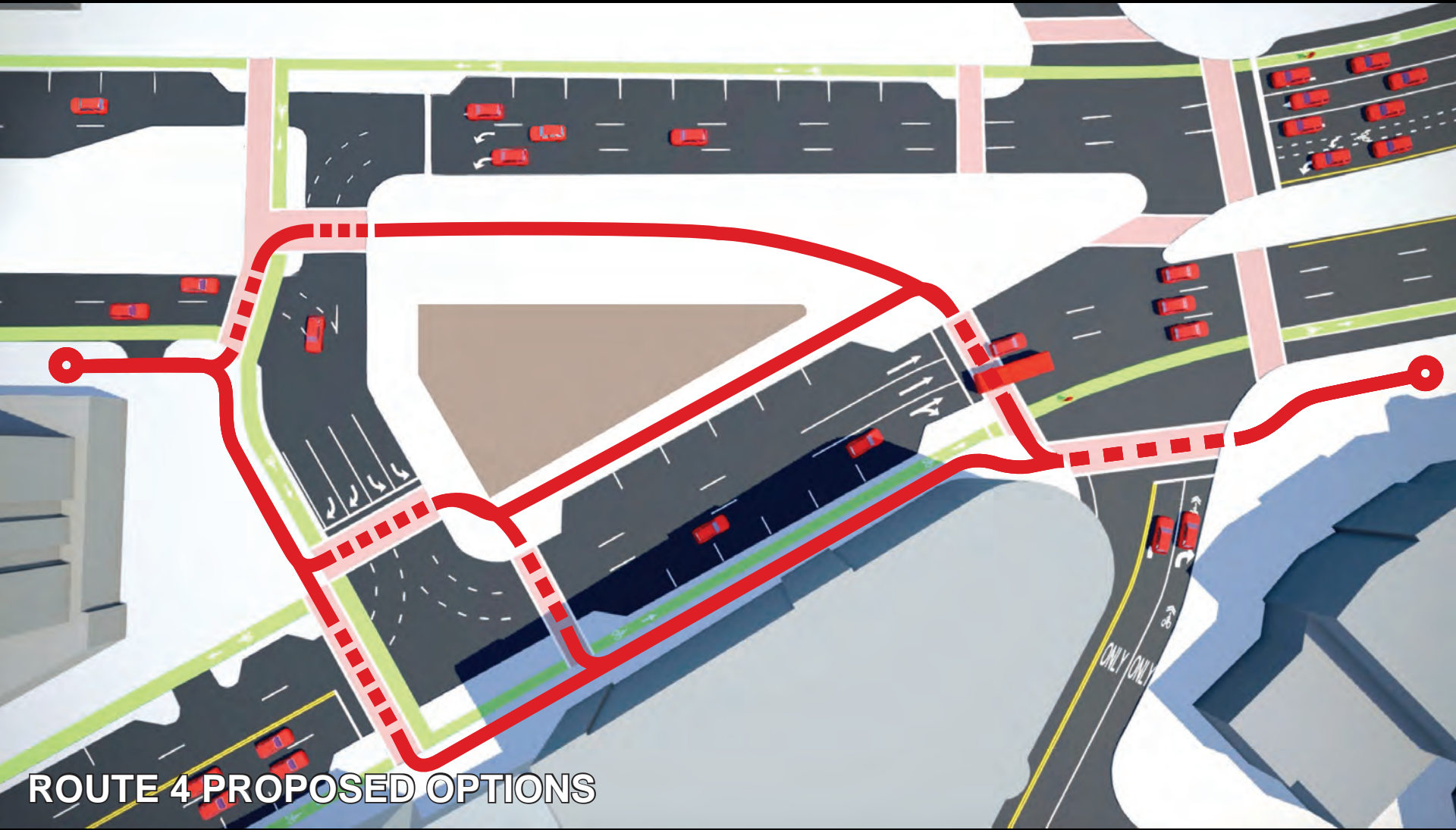

ROUTE 4 PROPOSED OPTIONS

Public Realm
8,700 ft²



Existing Public Realm Existing Crossing



Public Realm
32,300 ft²

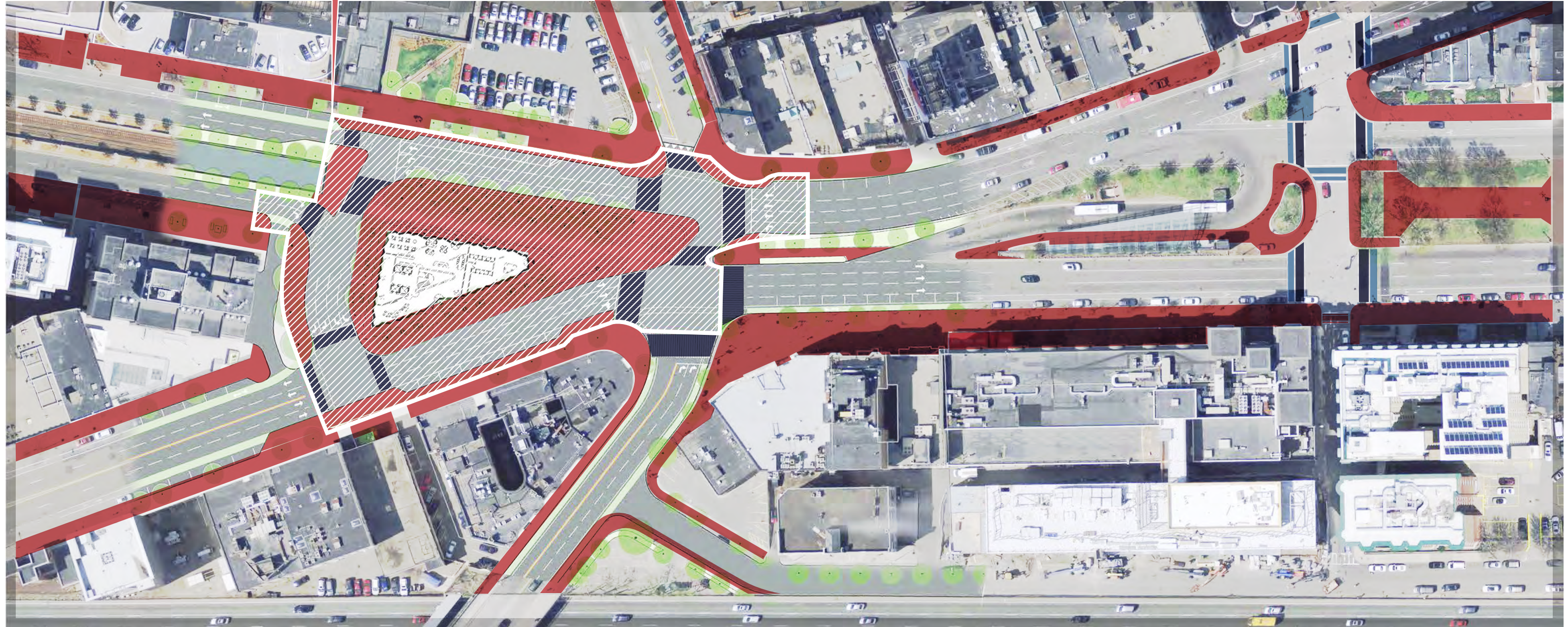

Proposed Public Realm Existing Crossing



Kenmore Square Today

Current Crosswalks

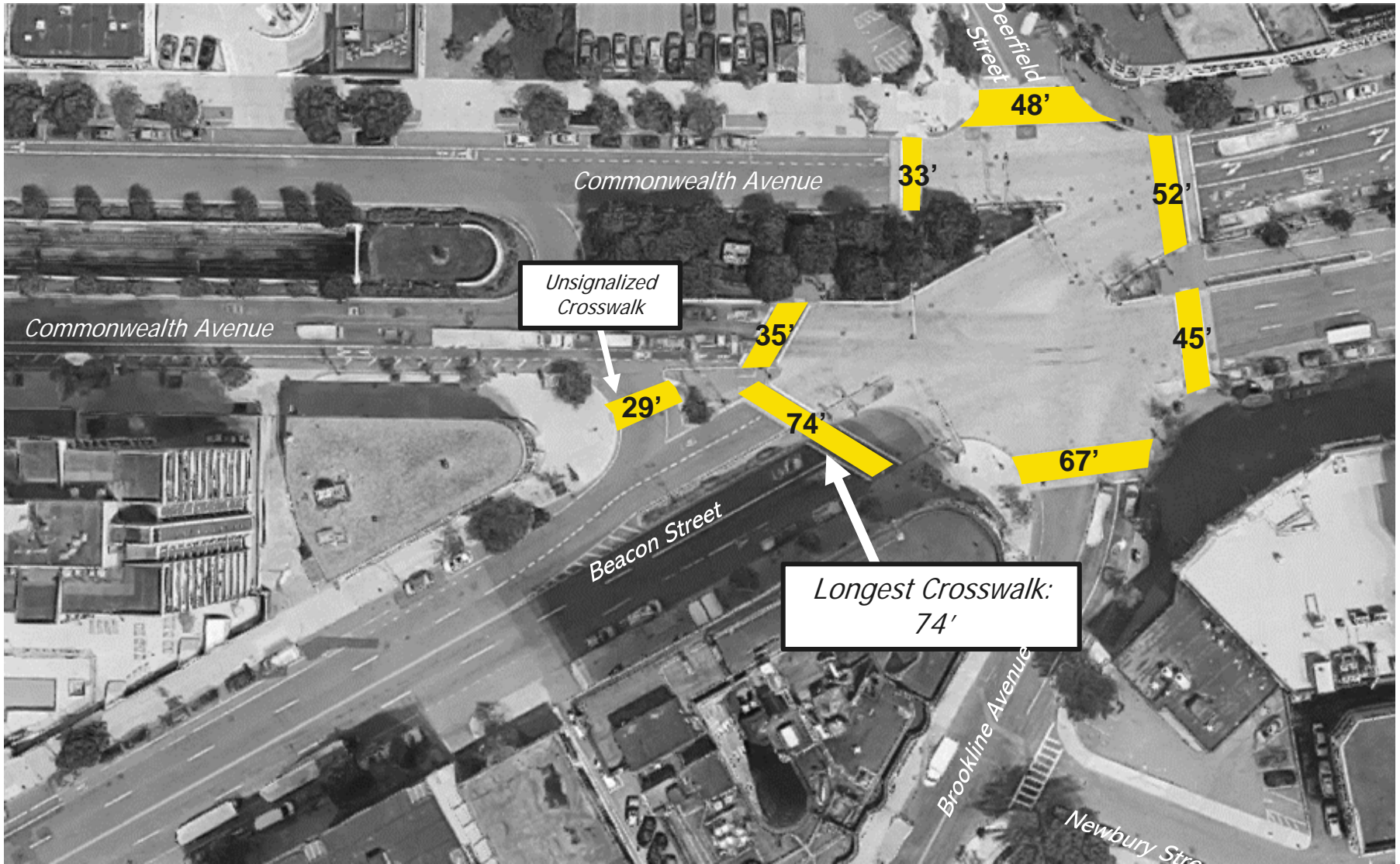

Kenmore Square with Proposed Changes

Planned Crosswalks

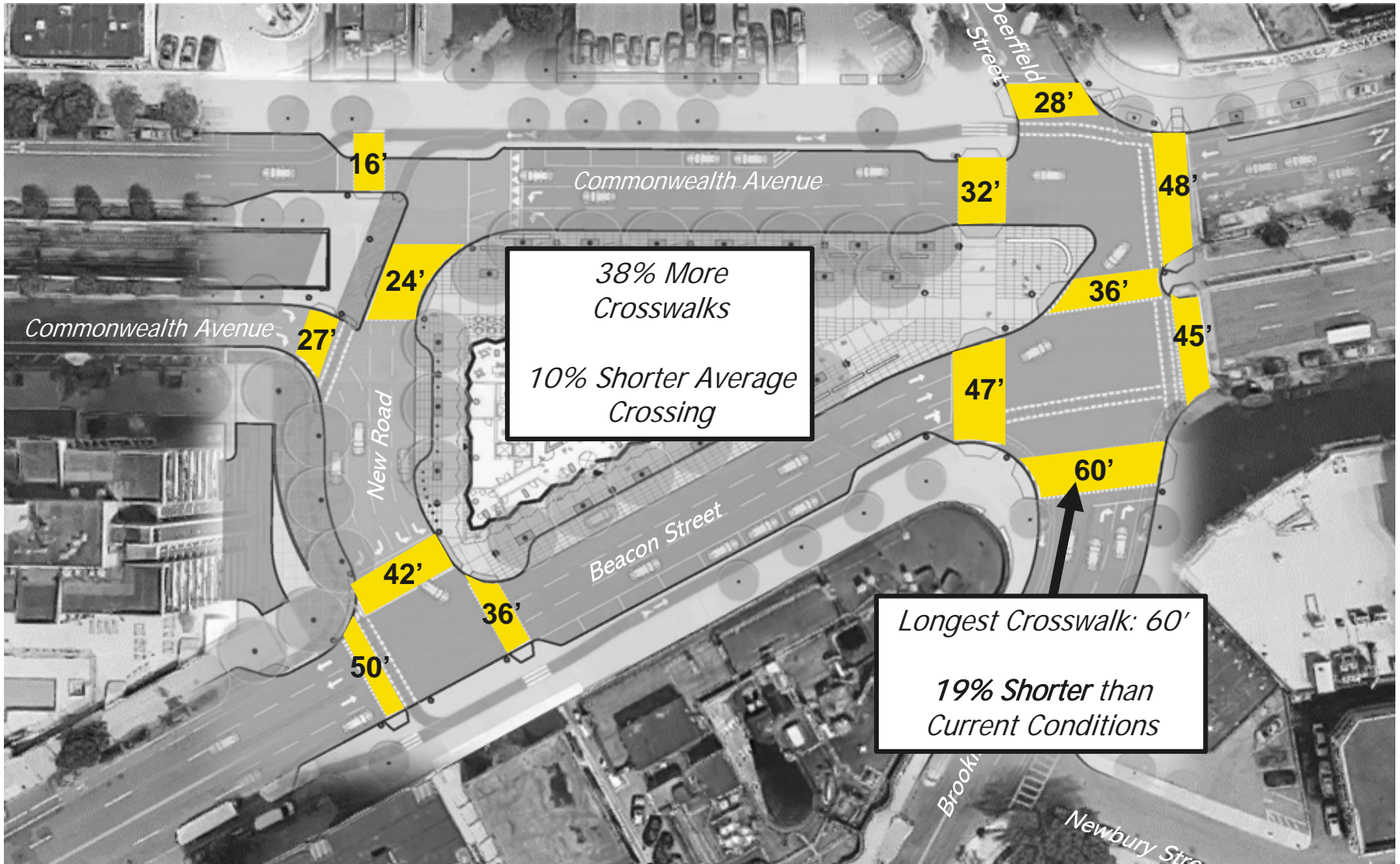

Kenmore Square Today

Current Bicycle Facilities

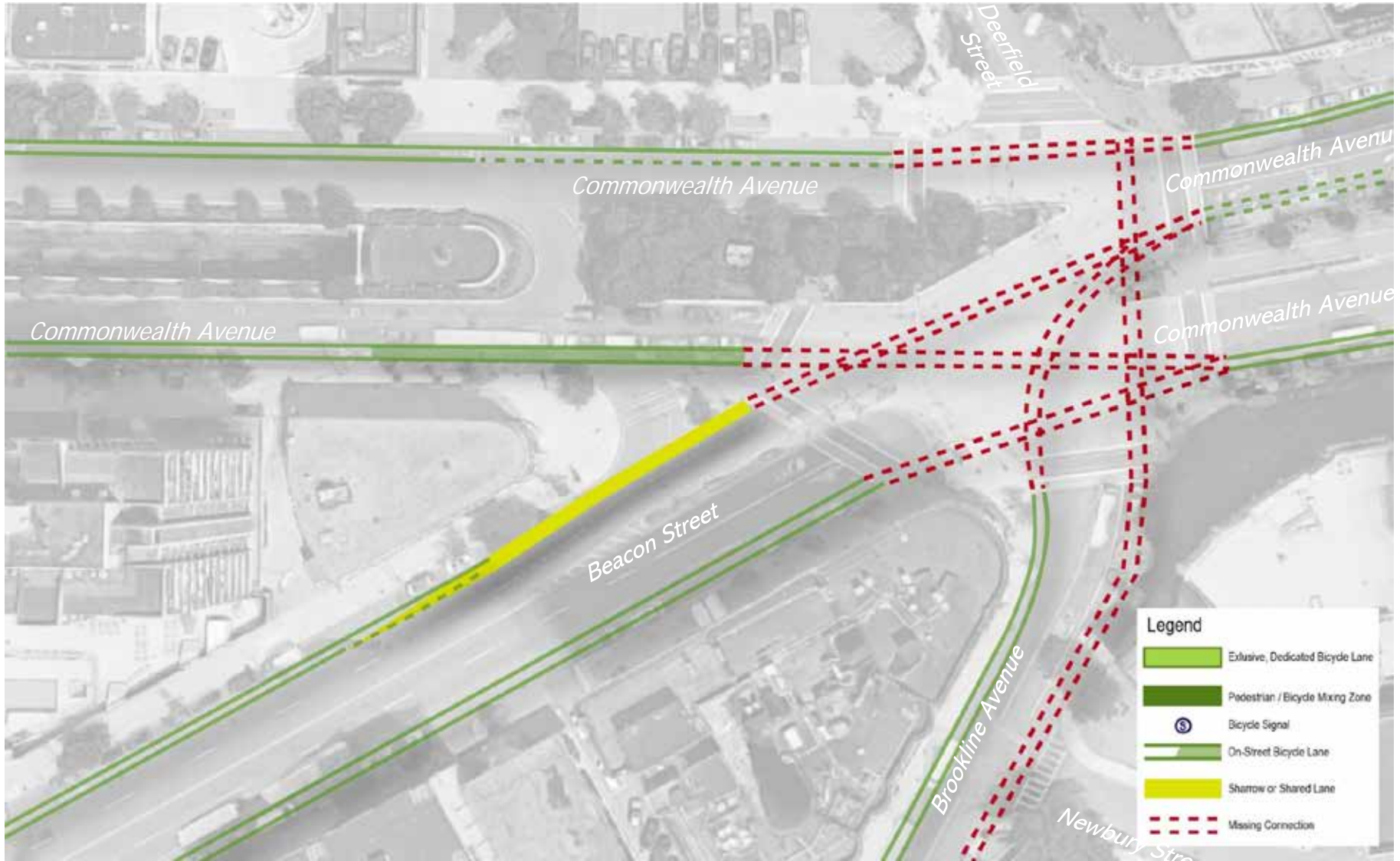

Kenmore Square with Proposed Changes

Planned Bicycle Facilities

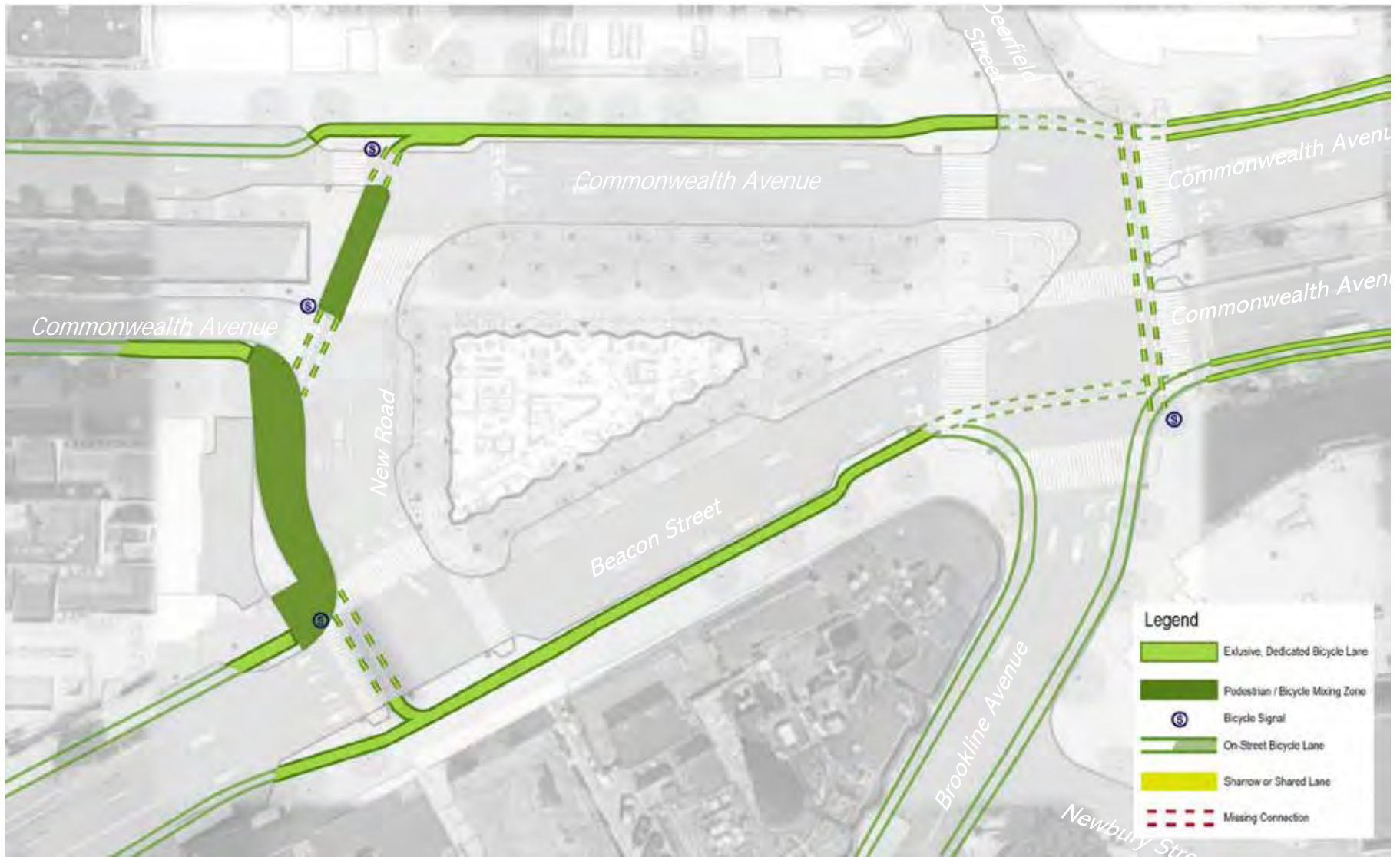

Intersection Vehicle Level of Service

Existing, No-Build and Build Conditions

Intersection	Current Network				Proposed Network					
	Existing Conditions		No-Build Conditions		Existing Conditions		No-Build Conditions		Build Conditions	
Beacon / Brookline / Deerfield / Commonwealth	D	E	E	F						
Brookline / Deerfield & Commonwealth / Beacon					B	C	B	C	C	C
New Road & Commonwealth					C	B	B	C	B	C
Beacon & New Road					B	B	C	C	C	C
Kenmore & Commonwealth EB	A	B	A	B	A	A	A	A	A	A
Kenmore & Commonwealth WB	C	D	C	D	D	D	D	D	D	D
Kenmore / Raleigh & Beacon	F	F	F	F	C	D	D	E	D	E

The proposed network shows acceptable LOS at almost all intersections



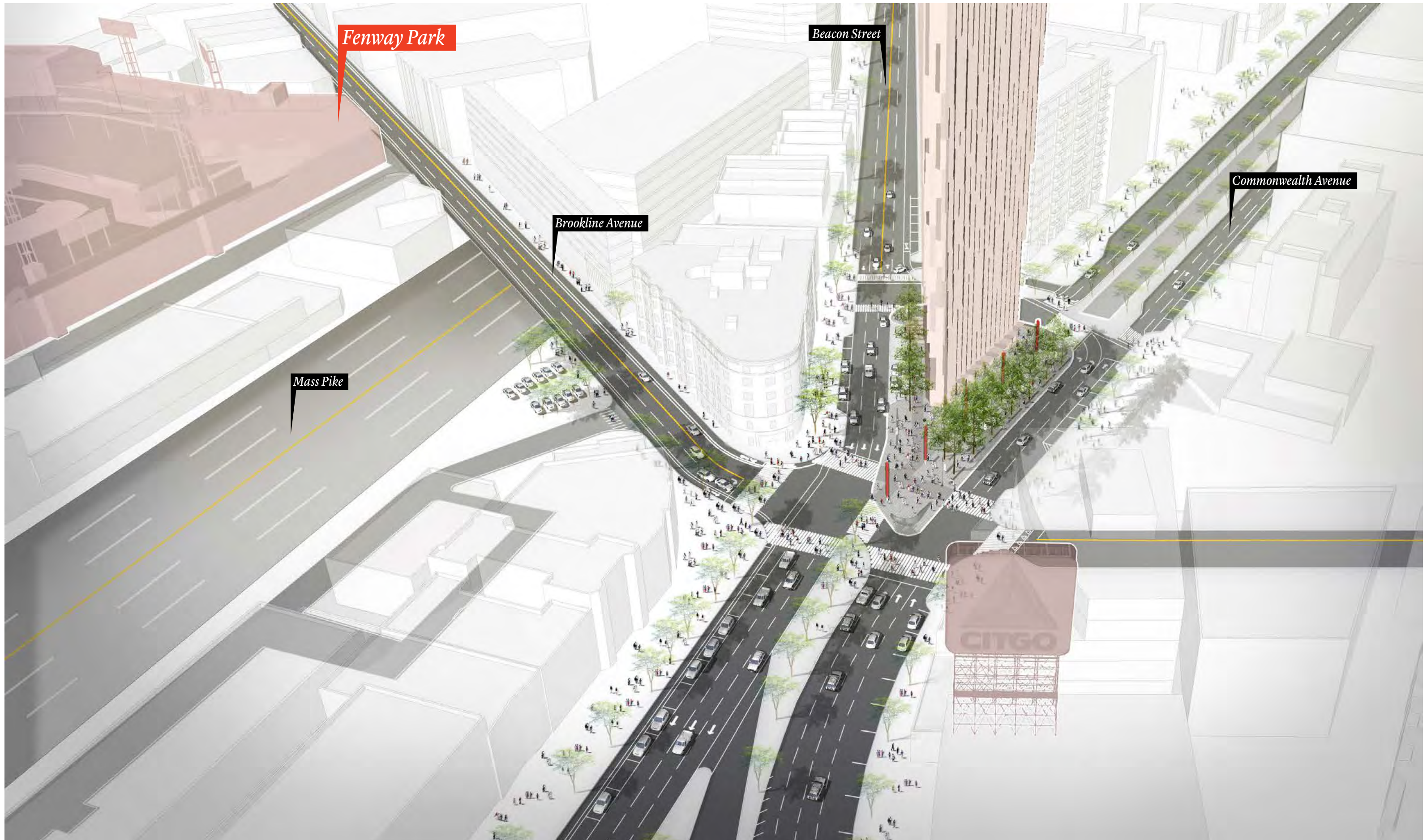



Fenway Park

Beacon Street

Commonwealth Avenue

Brookline Avenue

Mass Pike

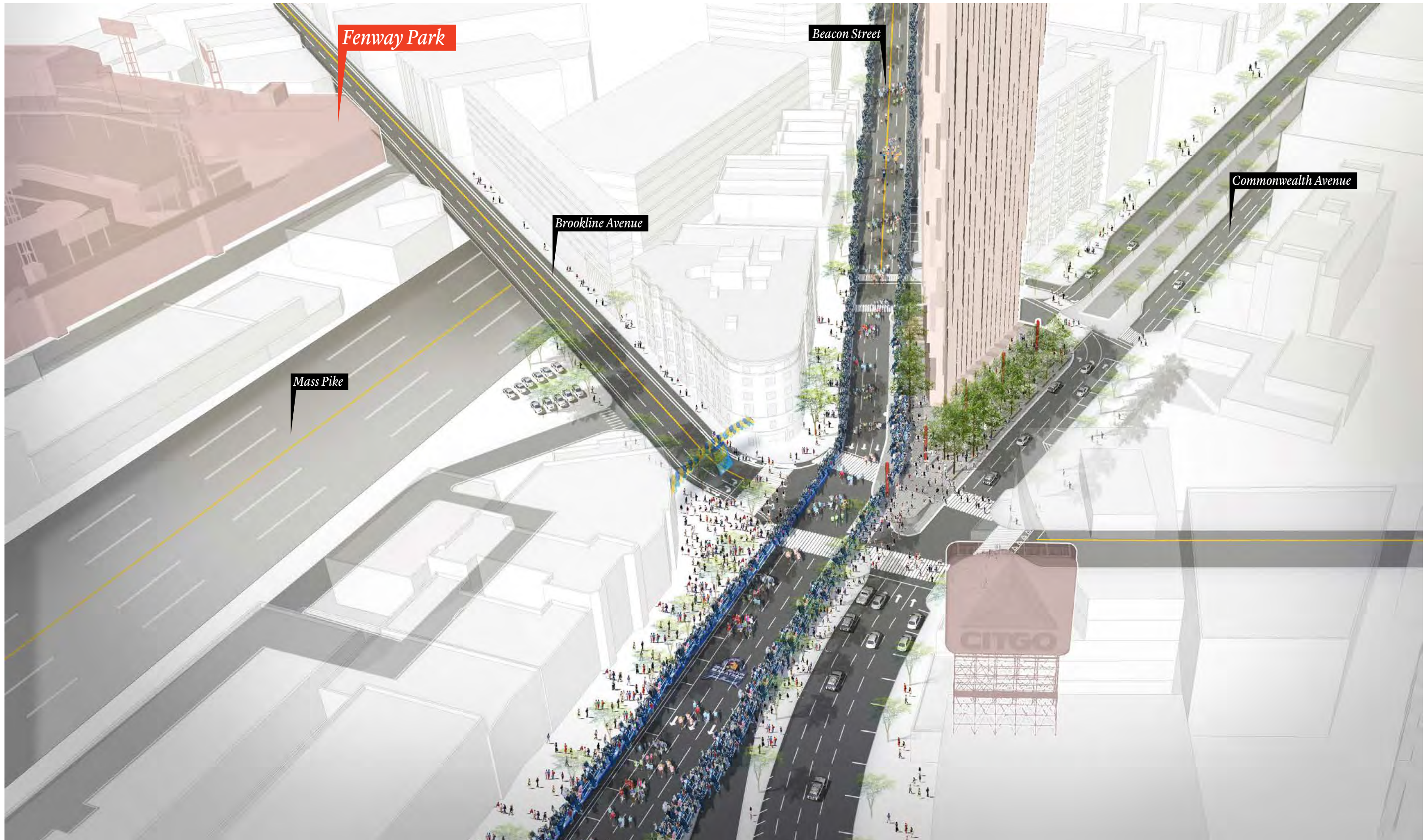

One Kenmore Square

Design Updates...







View West on Commonwealth Avenue

Kenmore Square
07/02/2019

STUDIO/
GANG
/ARCHITECTS

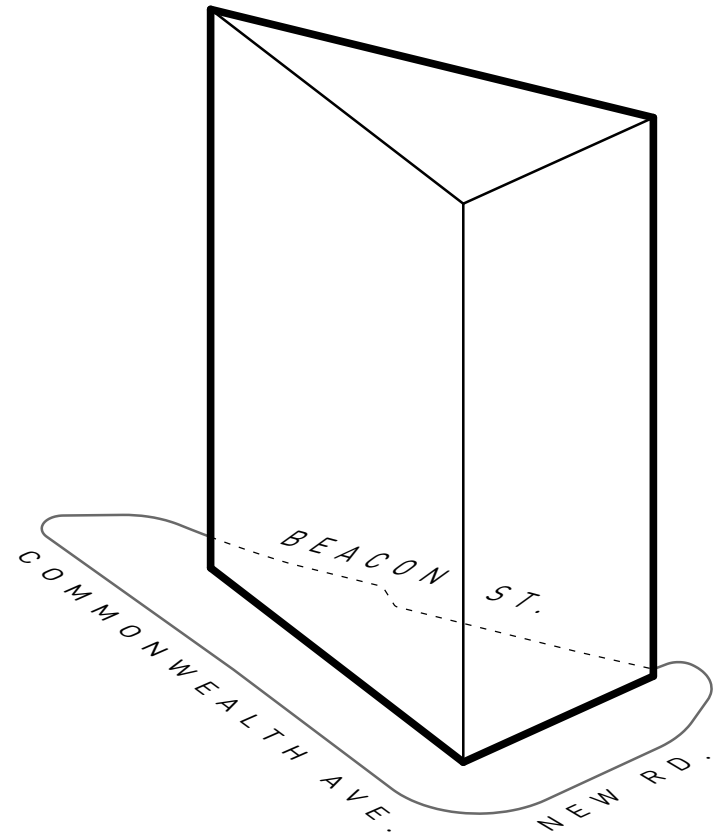

EXTRUDE

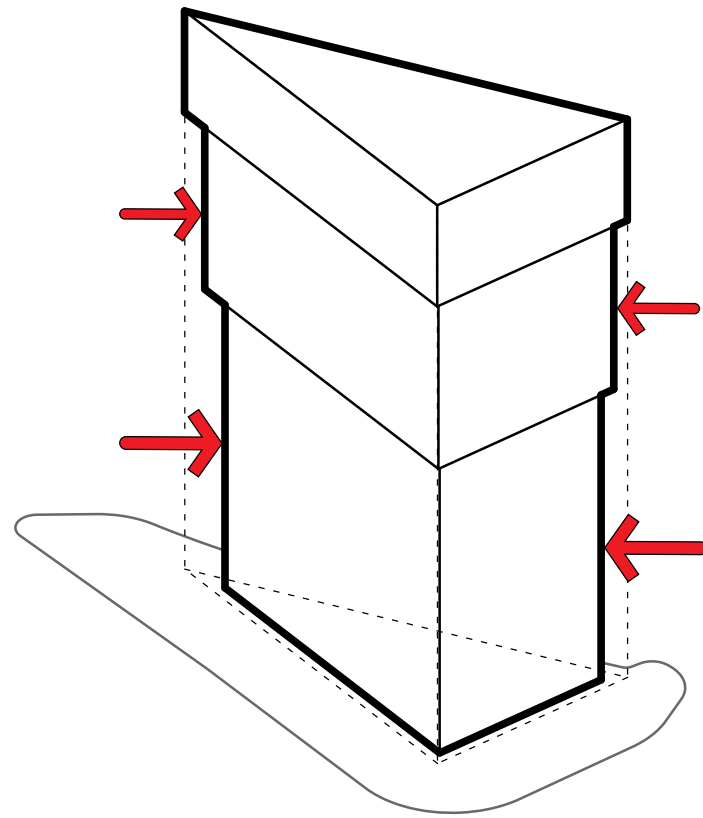

CARVE

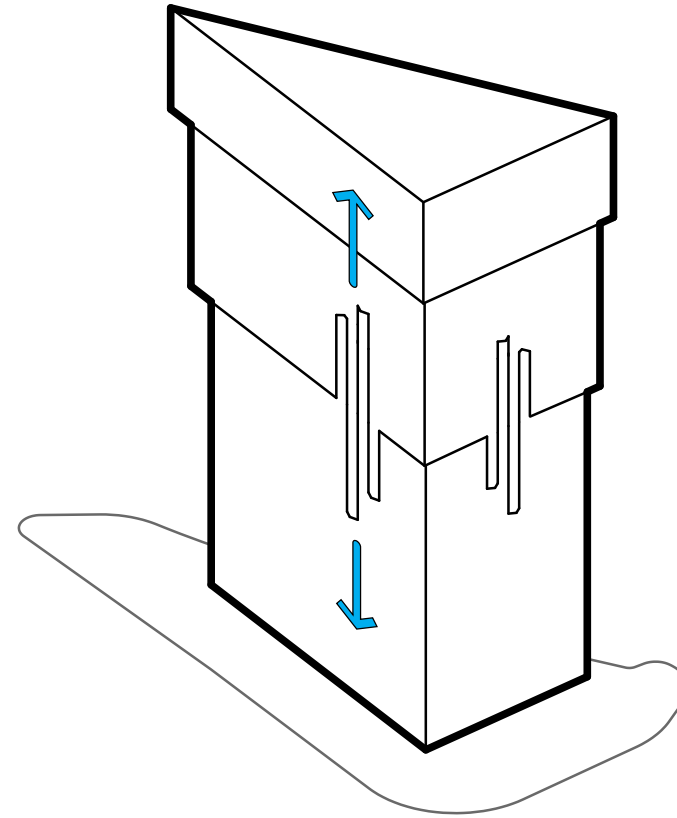

BLEND

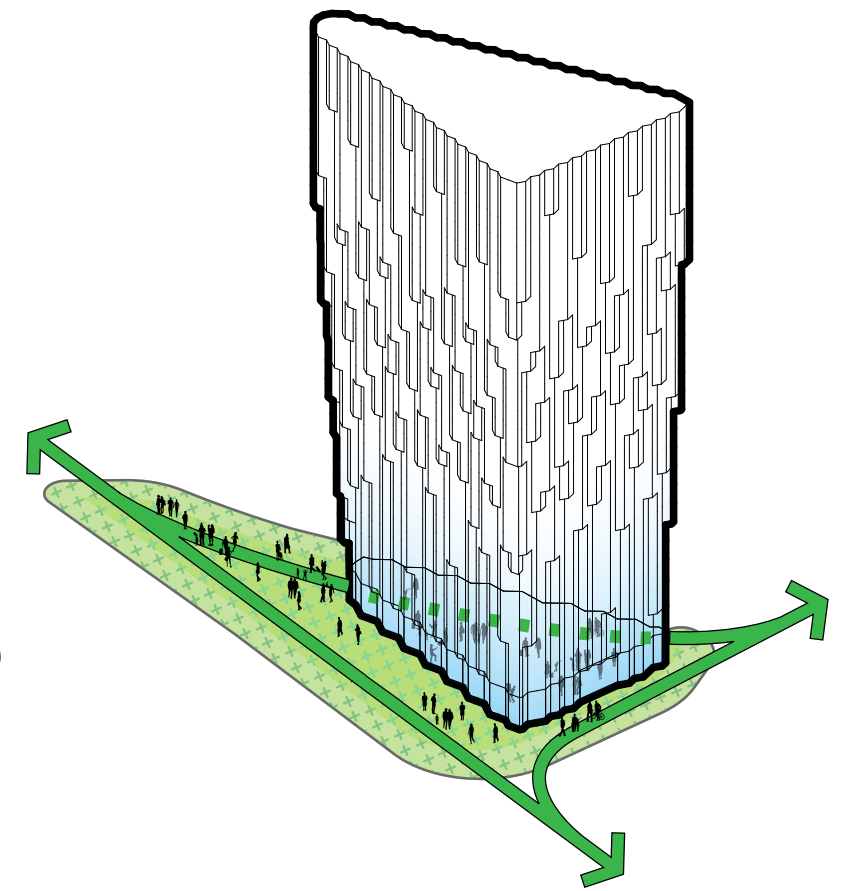

CONNECT

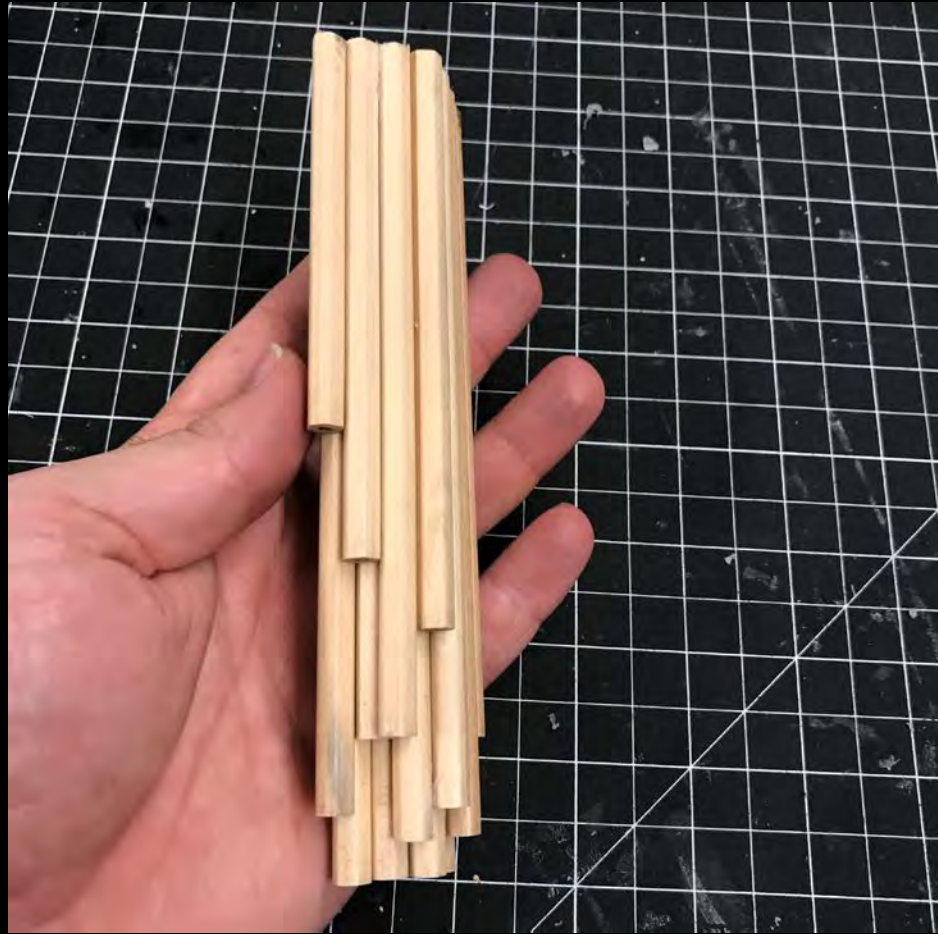

Massing Concept

Kenmore Square
07/02/2019



Model Photos

Kenmore Square
07/02/2019



View East on Commonwealth Avenue

Kenmore Square
07/02/2019

STUDIO/
GANG
/ARCHITECTS



L1 Plan

Kenmore Square
07/02/2019

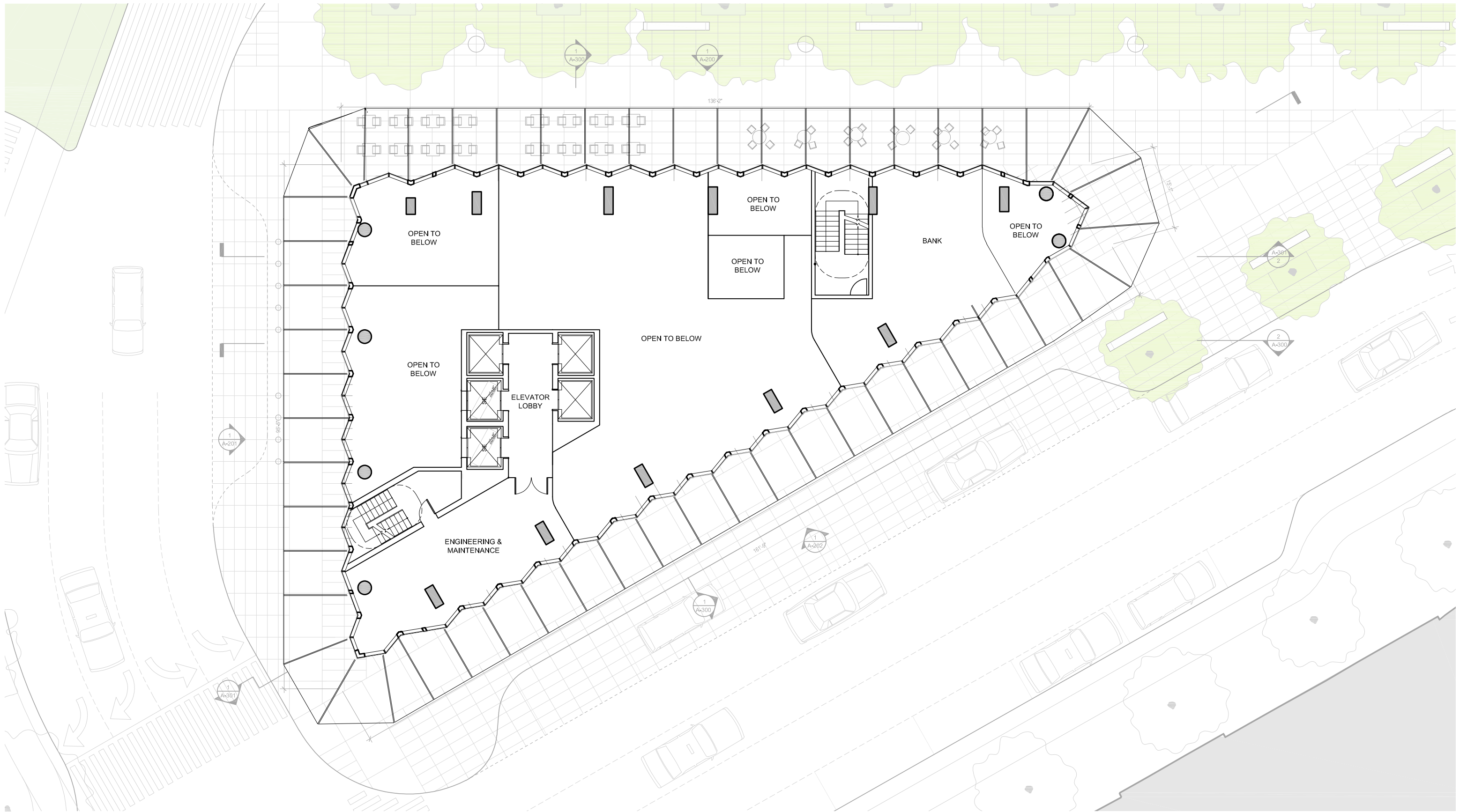

L2 Plan

Kenmore Square
07/02/2019

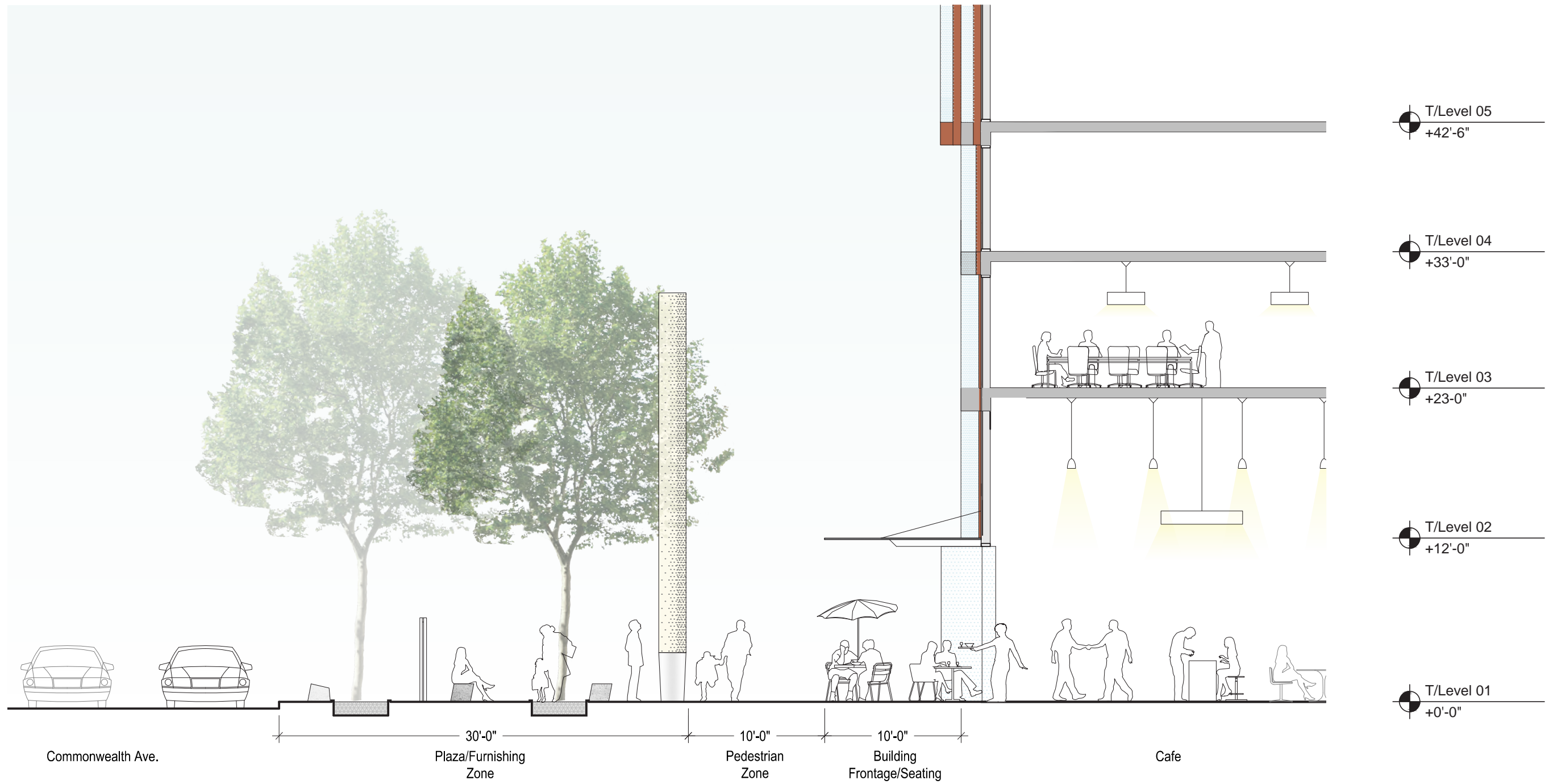

SECTION A - COMMONWEALTH AVE.

1/8"=1'

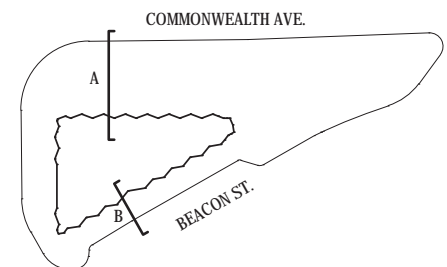

Street Section A

Kenmore Square 1/8"=1'
07/02/2019



Canopy Precedents

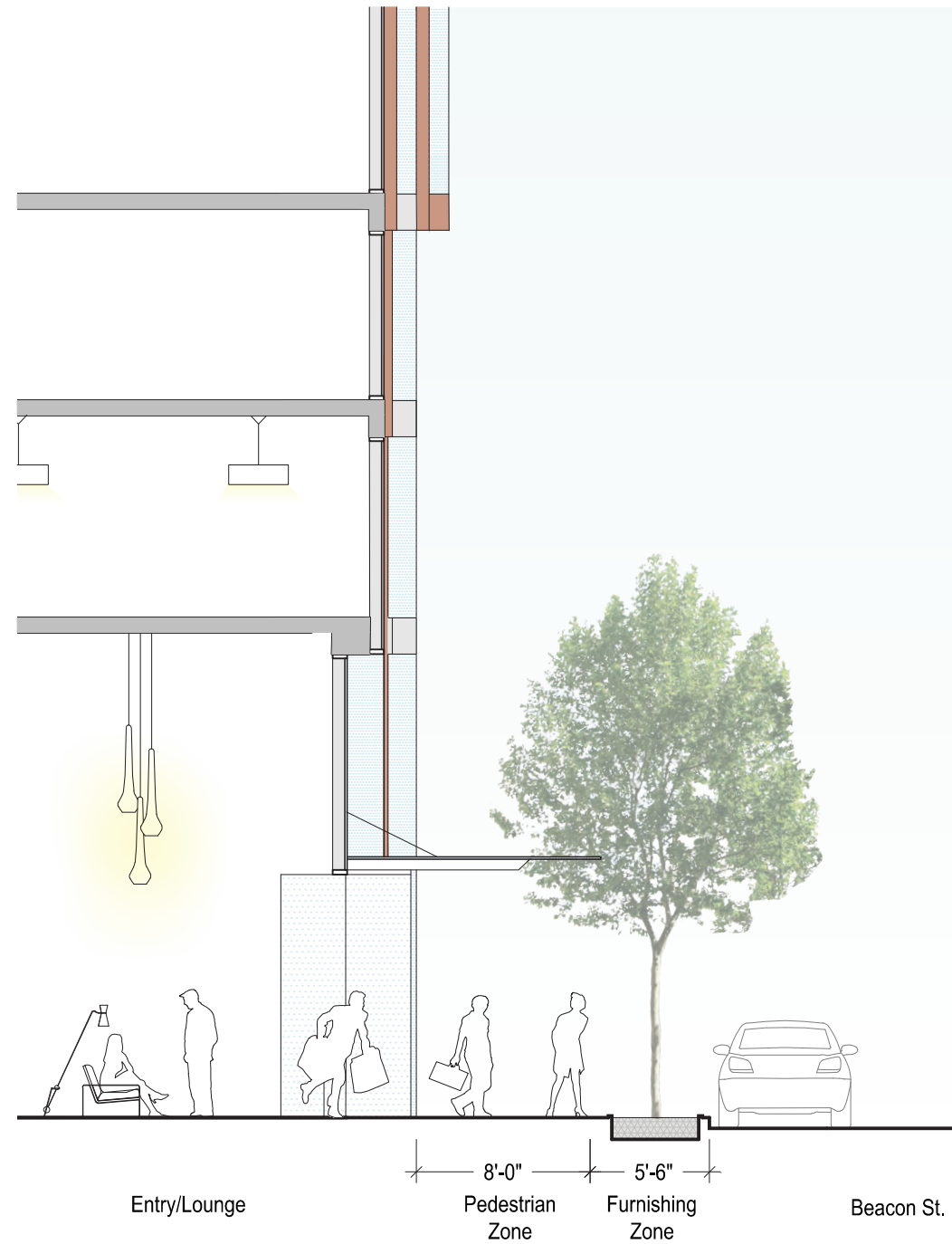

- T/Level 05
+42'-6"
- T/Level 04
+33'-0"
- T/Level 03
+23'-0"
- T/Level 02
+12'-0"
- T/Level 01
+0'-0"

SECTION A - BEACON ST.

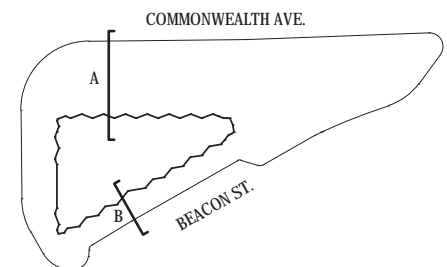

Street Section B

Kenmore Square 1/8"=1'
07/02/2019

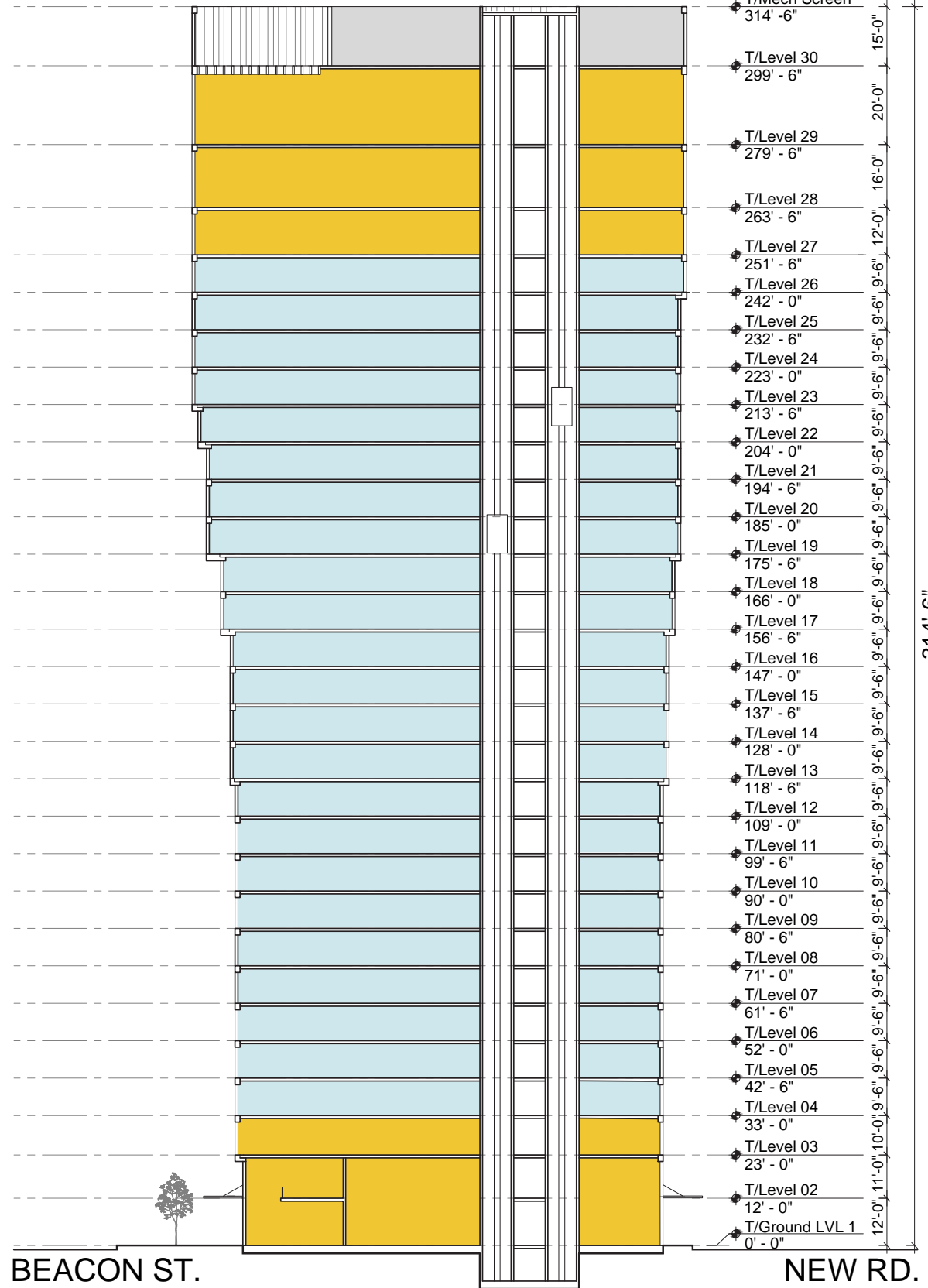
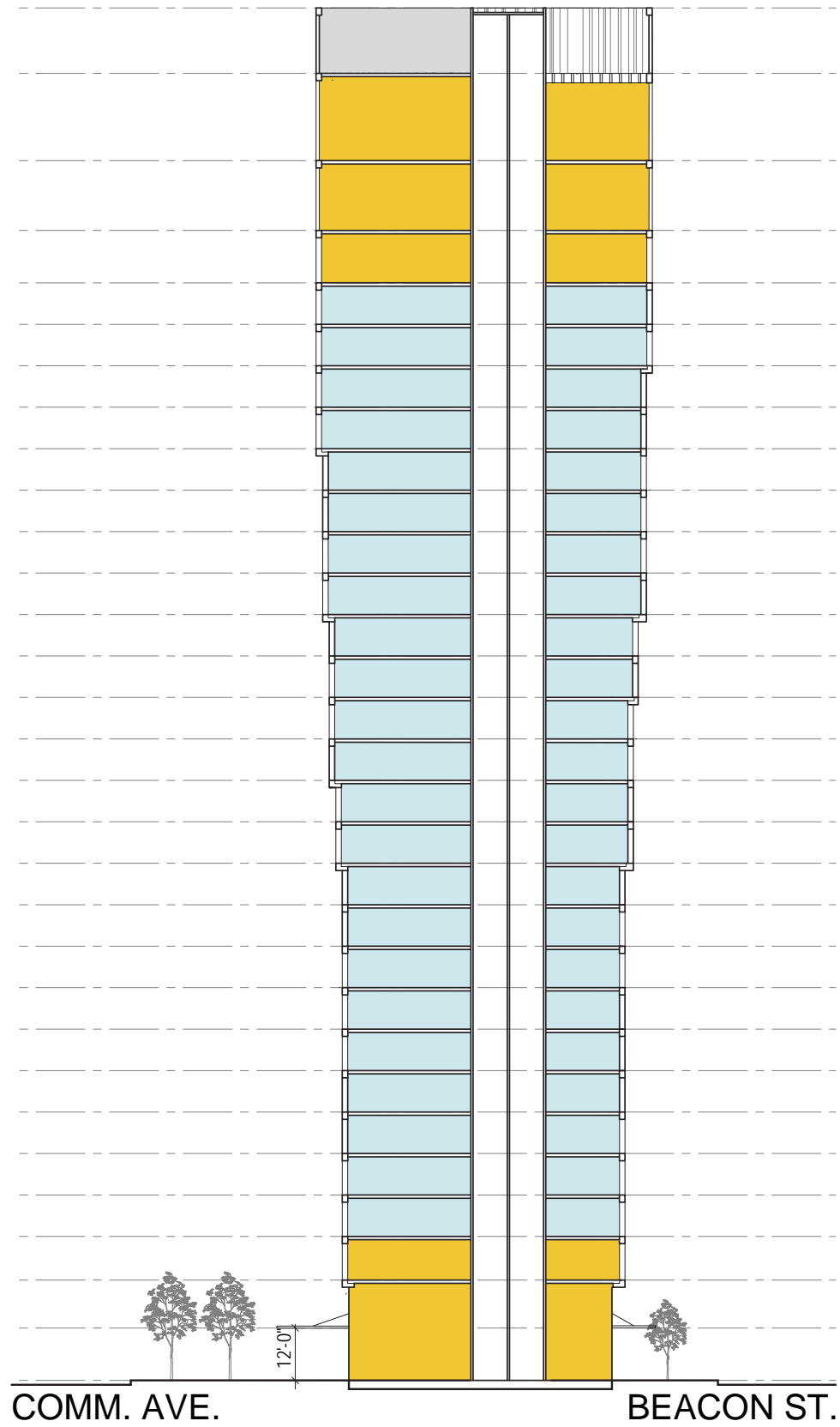

- Mechanical
- L29: Rooftop Bar + Lounge
- L28: Event Space
- L27: Meeting Rooms, Fitness
- L17-26: Guest Rooms, Upper Tranche
- L4-16: Guest Rooms, Lower Tranche
- L3: Offices, Staff Areas
- L2: Bank
- L1: Lobby, Café + Lounge, Loading + Service, Bank Vestibule



Building Sections

Kenmore Square
07/02/2019

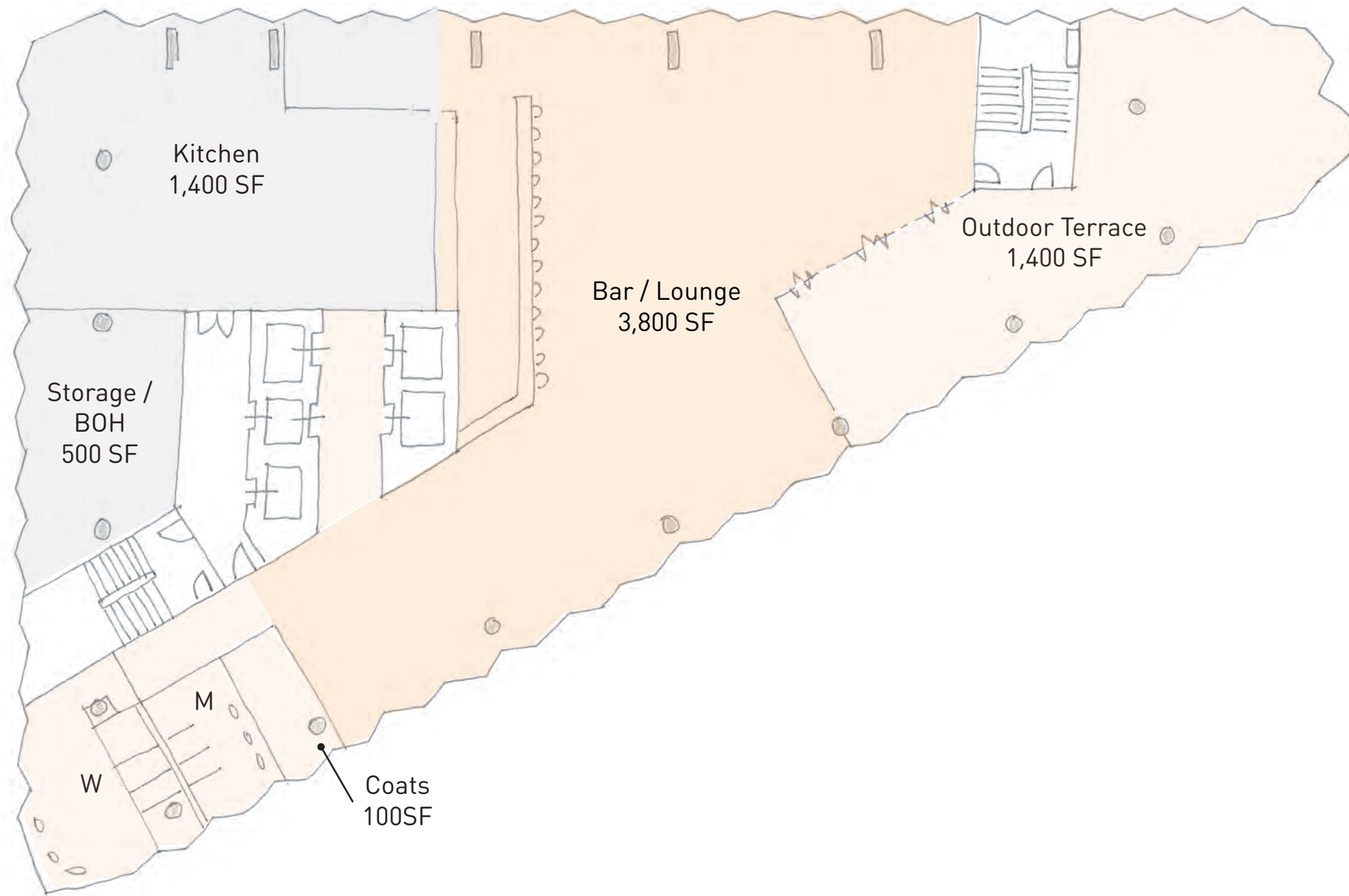

Bar/Lounge: 3,800 SF
 Outdoor Terrace: 1,400 SF
 BOH: 1,900 SF
 Overall floor area: 10,016 GSF

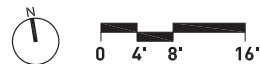

L29 Rooftop Bar Plan

Kenmore Square
 07/02/2019



Rooftop Bar Precedents

Kenmore Square
07/02/2019

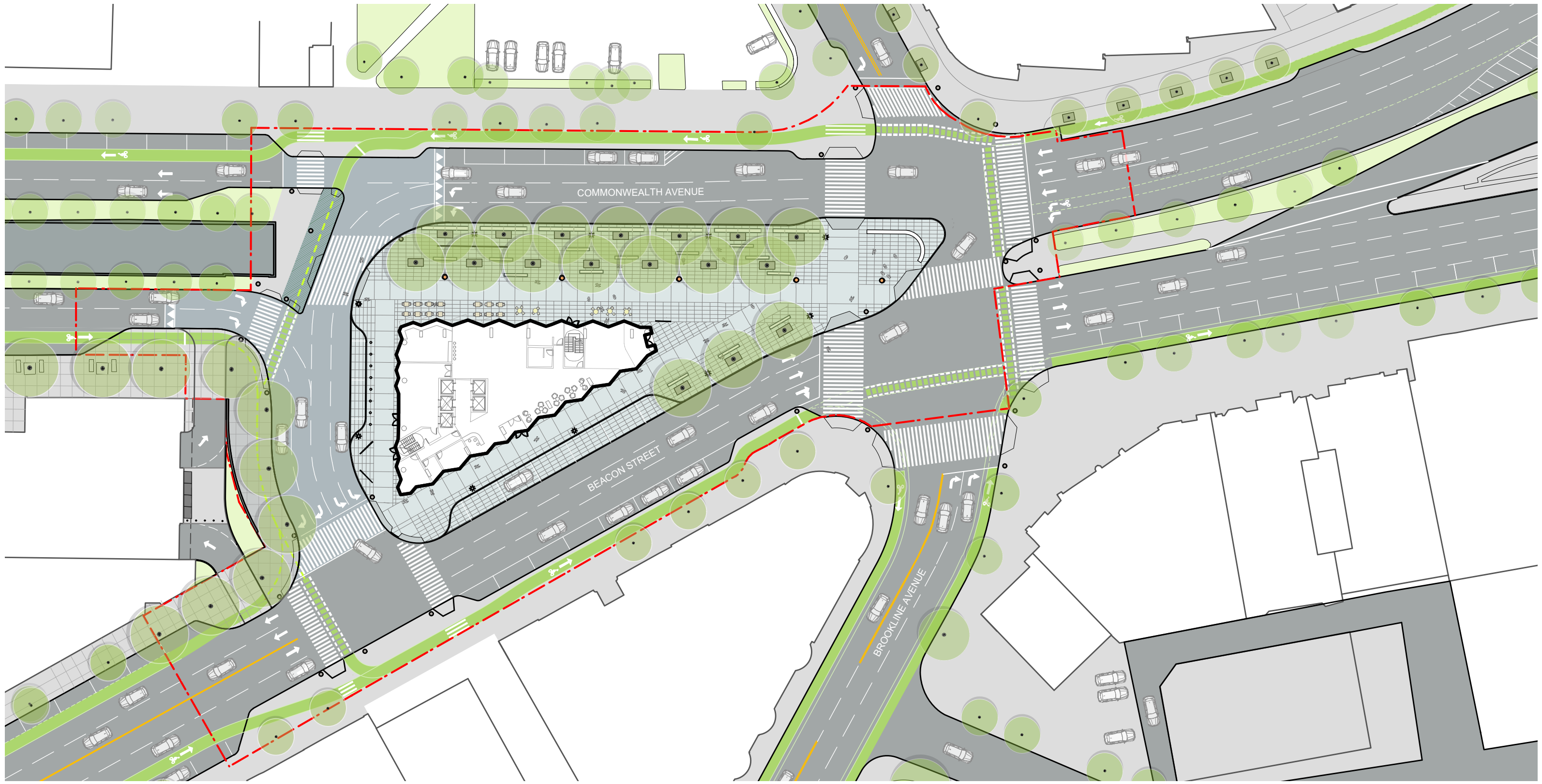





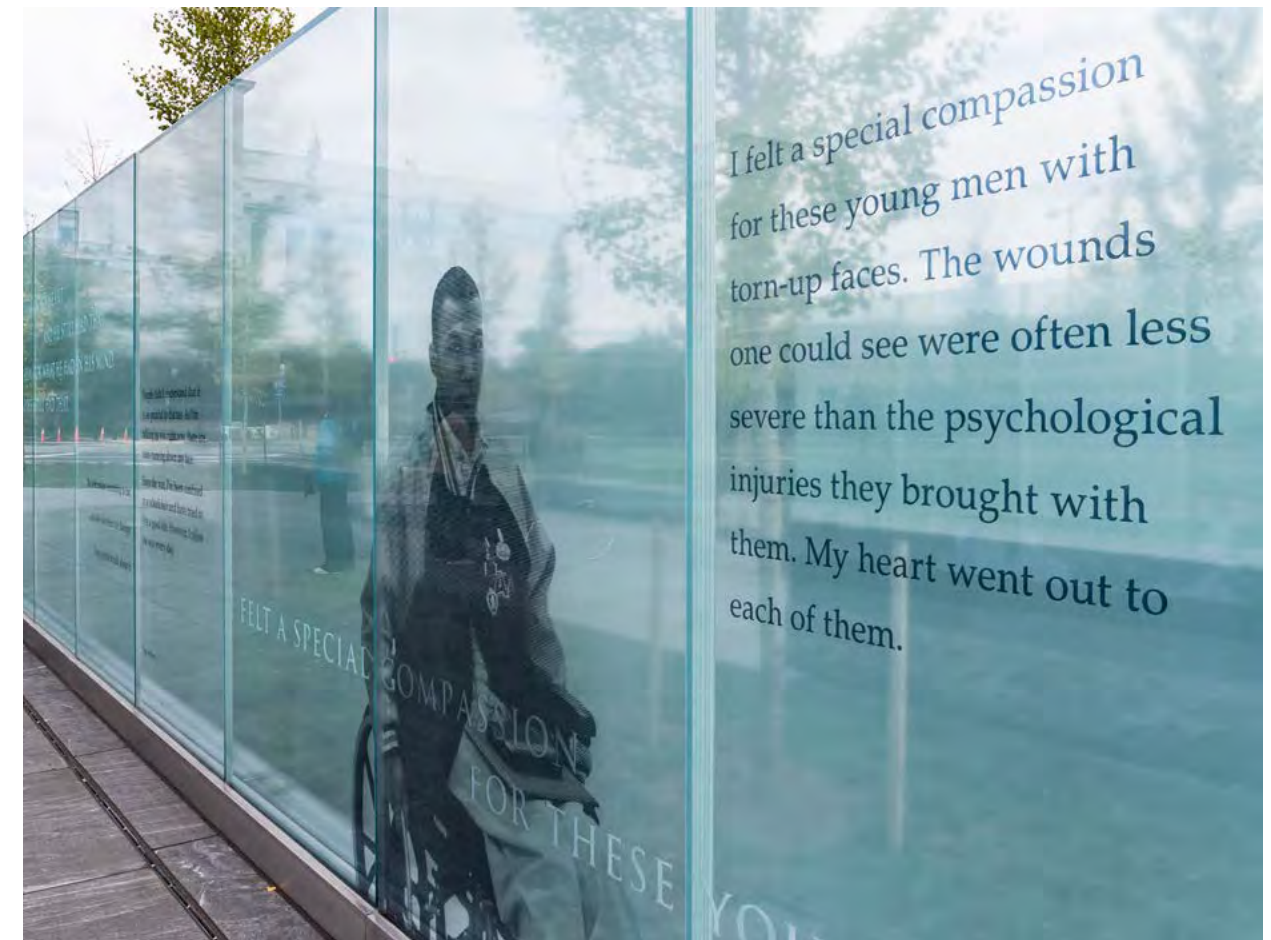



View West w/Future Developments

Kenmore Square
07/02/2019



View East w/Future Developments

Kenmore Square
07/02/2019



THANK YOU