

September 15, 2017

BY EMAIL AND  
HAND DELIVERY

Mr. Michael Rooney  
Project Manager  
Boston Planning and Development Agency  
One City Hall Square, 9th Floor  
Boston, MA 02201-1007

Re: Amended and Restated Development Plan for Planned Development Area  
No. 78, Seaport Square Project, South Boston

Dear Mr. Rooney:

In accordance with Section 80C-5 and Section 80C-7 of the Boston Zoning Code (the "Code"), and on behalf of Seaport Square Development Company LLC and its affiliates (the "Proponent"), I am pleased to enclose for filing eight (8) copies of an Amended and Restated Development Plan for Planned Development Area No. 78, Seaport Square Project, South Boston (the "Amended and Restated PDA Plan"). In connection with the Amended and Restated PDA Plan filing, please also find the following:

1. Fact Sheet (eight (8) copies); and
2. Public Notice that the Proponent will place in the Boston Herald within the next five days, as required by Section 80A-2 of the Code.

We thank you and the rest of the BPDA staff for your hard work and thoughtful feedback during the development of this Amended and Restated PDA Plan. We look forward to working with you toward the BPDA's approval of the plan.

Very truly yours,



Peter N. Kochansky

Enclosures

Mr. Michael Rooney  
September 15, 2017  
Page 2

---

cc: (with enclosures; by e-mail)  
Mr. Jonathan Greeley  
Mr. Jeffrey Hampton  
Marybeth Pyles, Esq.  
Mr. Jeremy Sclar  
Mr. Richard A. Marks  
Mr. Yanni Tsipis  
Mr. Jeffrey Curley  
Ms. Amy Prange  
Douglas M. Husid, Esq.

8992652.1

**AMENDED AND RESTATED DEVELOPMENT PLAN  
For  
PLANNED DEVELOPMENT AREA NO. 78**

**SEAPORT SQUARE PROJECT  
South Boston**

**Dated: \_\_\_\_\_, 2017**

**I. Development Plan**

In accordance with Sections 3-1A and 80C-3 of the Boston Zoning Code (the “Code”), this Amended and Restated Development Plan constitutes a Planned Development Area Development Plan (the “Amended Plan” or “Plan”) for development of the Seaport Square Project (the “Project”, as more particularly described below), an approximately 1,460,572 square-foot (approximately 33.5 acres) PDA Area (the “PDA Area”) in the South Boston Waterfront District. The PDA Area is described in more detail below, and in the legal descriptions attached as **Exhibit A** hereto and the PDA Area Plan attached as **Exhibit B** hereto. The PDA Area includes existing public ways and other streets, as well as several parcels of land of varying sizes owned by the Proponent, which are contiguous or separated by existing streets, as described below.

This Amended Plan amends and supersedes the Development Plan for Planned Development Area No. 78, dated September 21, 2010 and with an Effective Date of October 13, 2010, as amended by the First Amendment (Effective Date December 20, 2012), Second Amendment (Effective Date January 22, 2014), Third Amendment (Effective Date September 5, 2014), Fourth Amendment (Effective Date May 22, 2015), Fifth Amendment (Effective Date March 1, 2016), and Sixth Amendment thereto (Effective Date May 25, 2016) (as so amended, the “Original Plan”).

Since the adoption of the Original Plan, the Proponent’s predecessor-in-interest MS Boston Seaport, L.L.C. (the “Original Proponent”) conveyed Block A, Blocks B and C, Block H, Block K, Block J, Block L-1, Block L-2, Blocks M1 and M2 (collectively the “Developed Blocks”) to third party developers (“Developed Block Owners”) for the development of such Blocks. Updates on the status of buildings and other improvement on the Developed Blocks, and the public realm improvements associated with each such Block, are described in more detail in Section III below. This Plan refers to Block D, Block F, Block G, Blocks L3 – L-6, Block N, Block P, and Block Q as the “Remaining Blocks.” The Proponent intends to develop the Remaining Blocks to complete the mixed-use Project, which will include residential, retail, office, hotel, open space, innovation, civic and cultural uses, as well as public and accessory parking. This Amended Plan sets forth the proposed location and appearance of structures, open spaces and landscaping, proposed uses of the area, densities, proposed traffic circulation, parking and loading facilities, access to public transportation, and proposed dimensions of structures.

Capitalized terms used herein but not defined shall have the meanings specified in the Code.

**II. Proponent**

The Proponent of this Plan is Seaport Square Development Company LLC, a Delaware limited liability company, and its affiliates, and their respective successors and assigns (collectively, the “Proponent”).

The business address, telephone number, and designated contact for the Proponent are:

c/o WS Development  
 33 Boylston Street, Suite 3000  
 Chestnut Hill, MA 02467  
 Contact: Jeremy Sclar  
 Richard A. Marks  
 (617) 232-8900

**III. PDA Area Description**

The PDA Area consists of approximately 1,460,572 square-foot (approximately 33.5 acres), which area includes the horizontal area of a certain air rights parcels adjacent to Block P (the “Block P Air Rights Parcel”), bounded generally by Old Sleeper Street, Sleeper Street, Stillings Street, and Boston Wharf Road to the west; Northern Avenue and Seaport Boulevard to the north, Pier 4 Boulevard and B Street to the east, and Summer Street and property of various owners to the South, as described on Exhibit A and shown on Exhibit B, the “PDA Area Plan”, attached hereto. For development purposes, and for the purposes of this Plan, the Original Proponent divided the PDA Area into twenty lettered parcels (each a “Block”), as shown on the PDA Area Plan attached as Exhibit B, plus areas to be occupied by public realm improvements such as new streets and sidewalks, as shown on Exhibit C, “Public Realm Improvements,” Exhibit D, “Block Plans,” and Exhibit H, “Proposed Street Dimensions.” The Developed Blocks are held in separate ownership, and the Remaining Blocks and other land within the PDA Area are owned by affiliates of the Proponent. Each Block, group of Blocks, building or group of buildings being developed in one continuous sequence or phase is referred to herein as a “Project Component.”

Between 2011 and 2015, the Original Proponent conveyed the Developed Blocks to third party entities for the development of those Blocks. Table 1 below lists the status of the buildings on each such Block, the program elements, and current or anticipated uses. All of the Public Realm Improvements required to be constructed with the Developed Blocks have either been constructed or will be constructed in conjunction with the buildings on such Blocks, all as required by the Original Plan.

**TABLE 1**

<b>Developed Blocks</b>		
<b>Block</b>	<b>Current/Planned Use</b>	<b>Status</b>
Block A	Hotel	Completed
Block B	Residential, Retail/Entertainment/ Restaurant/Services, Parking	Under Construction
Block C	Residential, Retail/Entertainment/ Restaurant/Services, Parking	Under Construction
Block F	Open Space Uses, Innovation Center (Early Action Public Benefits)	Completed
Block H	Place of Worship, Office, Retail	Completed
Block J	Hotel	Completed

<b>Developed Blocks</b>		
<b>Block</b>	<b>Current/Planned Use</b>	<b>Status</b>
Block K	Residential, Retail/Entertainment/ Restaurant/Services, Parking	Completed
Block L-1	Office, Retail/Entertainment/ Restaurant/Services, Parking	Completed
Block L-2	Office, Retail/Entertainment/ Restaurant/Services, Parking	Under Construction
Blocks M1/M2	Residential, Retail/Entertainment/ Restaurant/Services, Parking	Under Construction

In addition, affiliates of the Original Proponent constructed the Block Q Recreational Area (defined below), and District Hall (called the Innovation Center in the Original Plan), and the open space on Block F, as required by the Original Plan.

The Proponent acquired the Remaining Blocks from the Original Proponent in 2015, except for (i) portions of Block F and Block G, which the Proponent acquired from the Boston Redevelopment Authority in 2016 pursuant to a 1998 agreement among a previous site owner, the City of Boston, and the Boston Redevelopment Authority, now doing business as the Boston Planning and Development Agency (the “BRA” or the “BPDA”; and (ii) a portion of Block D occupied by the Chapel or Our Lady of Good Voyage, which it acquired from the Archdiocese of Boston in 2017. In addition, the existing public ways located within the PDA Area are now and will continue to be owned by public entities. The BPDA is the owner of a small parcel of land that is the site of the Farnsworth Pedestrian Link (defined below), and the Massachusetts Bay Transportation Authority (“MBTA”) owns a small parcel at the northern end of Thomson Place. Finally, pursuant to a 1997 agreement among the predecessor site owner, the Massachusetts Department of Highways (“MHD”), the MBTA, and Energy International, Inc., the Massachusetts Department of Transportation (“MassDOT”), as successor to MHD, is required to transfer to the Proponent certain fee and easement interests in the Block P Air Rights Parcel. The City of Boston owns two sliver parcels at the southeast corner of Block G. The Proponent intends to finalize all transfers required to construct the Project within the PDA Area. The portions of the PDA Area owned by the Developed Block Owners or by the Proponent, plus the land to be transferred to the Proponent as described above, are referred to herein as the “Project Site.”

The PDA Area is within the Fort Point Waterfront Subdistrict of the Harborpark District (the “Fort Point Waterfront”) governed by Article 42E of the Code, except for Block Q and the southern portion of Block K, which are within the M-4 Restricted Manufacturing Subdistrict, and the southern half of Summer Street, which is outside of the Harborpark District and within an I-2 Industrial Subdistrict. The entire PDA Area is within the Restricted Parking Overlay District. Blocks H, J, K and Q are within the Groundwater Conservation Overlay District (“GCOD”). Of the Remaining Blocks, portions of Blocks D, F, G, L3, L4, L5, L6, N, and P are designated as special flood hazard areas, Zone AE, on the Suffolk County Flood Insurance Rate Map issued by the Federal Emergency Management Agency, and are thus within a flood hazard special purpose overlay district (“FHSPOD”) and subject to the regulations set forth in Article 25 of the Code. Planned Development Areas (“PDAs”) are allowed on all portions of the PDA Area.

This Plan complies with the standards set forth in Section 3-1A(a) and Section 80C-4 of the Code. As described in the previous paragraph, this Plan is not for a location in which Planned Development Areas are forbidden by underlying zoning. The Project complies with the provisions of underlying zoning that establish use, dimensional, design, or other requirements for projects in Planned Development Areas, and that establish planning and development criteria, including public benefits, for Planned Development Areas. It complies with the regulations set forth in Sections 42E-16 of the Code, with the standards set forth in Section 42E-17, and with the public benefits criteria set forth in Section 42E-18. Approval of the Project by the BPDA under Large Project Review will confirm compliance with the general design and environmental impact standards set forth in Section 42E-20. As detailed herein, this Plan conforms to the plan for the districts, subdistricts and similar geographic area in which the PDA Area is located, and to the general plan for the City as a whole. The Project has been designed so as not to be injurious to the neighborhood or otherwise detrimental to the public welfare, weighing all the benefits and burdens of the Plan.

A small portion of the Project is located within the jurisdictional area of the existing South Boston Municipal Harbor Plan, submitted by the BRA and approved, with qualifications, by the Secretary of Environmental Affairs in 2000 (as subsequently amended, the “SBMHP”). The SBMHP focuses on the 128 acres of waterfront land in South Boston that are subject to Chapter 91 jurisdiction. Specifically, Block A and small portions of Blocks B, G, H and M1, making up approximately 1.64 acres (approximately 8% of the area of the Project Site), are subject to Chapter 91 licensing jurisdiction and governed by the SBMHP. Of the Remaining Blocks, only a portion of Block G is subject to Chapter 91 jurisdiction. As described in the DPIR and the 2017 NPC (both defined below) the Plan complies with the standards set forth under Section 42E-5 for a favorable recommendation by the BPDA under Section 18 of Mass. Gen. Laws Chapter 91 for those portions of the Project within Chapter 91 jurisdiction.

Blocks H, J, Q and K are located in the “Seaport Boulevard/Boston Wharf Road Protection Area” associated with the Fort Point Channel Landmark District. The goals of the Protection Area are to protect view corridors in and out of the adjacent landmark district and, through a design review process with the Fort Point Channel Landmark District Commission, to ensure that the massing, land coverage and height of new construction on adjacent lots is compatible with that of the landmark district. The construction of buildings and other improvements on the above-referenced Developed Blocks within the Protection Area was approved by the Fort Point Channel Landmark District Commission for consistency with the Protection Area guidelines.

#### **IV. General Description of the Project**

With the completion of the Developed Blocks and the Remaining Blocks, the Project will result in a vibrant urban neighborhood comprised of a mix of uses and open spaces, establishing approximately 20 new urban blocks in South Boston’s Waterfront District. The Project, including the Developed Blocks and the Remaining Blocks, includes the construction of the buildings described on **Exhibit D**, and the use of approximately 39% (approximately 9.2 acres) of the Project Site for streets, sidewalks and open space. The Project includes approximately 7,723,110 square feet of Gross Floor Area, as further described herein, of residential, retail, office, hotel, Innovation, civic and cultural uses, as well as below-grade accessory and non-accessory public parking. Most buildings include or will include retail, restaurant, entertainment, or other active uses at the street level. The Project Site will be approximately 1,023,396 square feet (including the horizontal area of the Block P Air Rights Parcel), resulting in a Floor Area Ratio (“FAR”) for the full Project of up to 7.55 (using the Project Site, including the horizontal area of the Block P Air Rights Parcel, as the Lot Area for calculating FAR for the Project). A description of individual components of the Project and the maximum Gross Floor Area of each of the

Project buildings is shown on **Exhibit D**. The above described proposed project, as further described in this Amended Plan, shall herein afterwards be referred to as the “**Project**”.

Civic/community and cultural uses are allowed on each of the Blocks, and may include, but shall not be limited to, public art installations, flexible gallery space, and performing arts uses, and the use of undeveloped Blocks and publicly-accessible open spaces for periodic events and other programming. Additional uses may include community uses and educational uses. The Proponent will construct a MBTA head house on Block F. The approved uses of each Block are described on **Exhibit E** attached hereto. A list of allowed uses for the PDA Area is set forth on **Exhibit F**.

The BPDA has approved the conceptual plans attached hereto as **Exhibit D**. Consistent with Section XIX of this Plan, final design of improvements and uses shall be subject to approval by the BPDA in accordance with its Development Review Procedures.

## **V. Compliance with Planning and Design Principles**

The Project has been designed to be consistent with the several urban planning and design plans that relate to the South Boston Waterfront District. The Seaport Public Realm Plan, issued by the BPDA in 1999, provided a set of principles for the district with the goals of promoting access to the waterfront; preserving and enhancing the industrial port and balancing the growth of mixed-use and recreational activities with the needs of maritime commerce; creating a vital mixed-use neighborhood; enhancing Boston’s economy by promoting manufacturing, hotel, commercial office, retail, and visitor industries; and mitigating the potential impacts of the development on the South Boston residential community and other City neighborhoods.

The SBMHP, approved in 2000 and subsequently amended, governs a small portion of the PDA Area within Chapter 91 jurisdiction, and the Fort Point Channel Watersheet Activation Plan, issued in 2002, promotes the use and enjoyment of Fort Point Channel. Other planning initiatives, including the 100 Acres Master Plan, the Fan Pier PDA Development Plan, the South Boston Waterfront Gateways Study, and the Crossroads Initiative, address different areas within the South Boston Waterfront District, and are discussed in detail in the Draft Project Impact Report/Draft Environmental Impact Report for the Project (“**DPIR**”) and the NPC (defined below).

The urban design principles that govern the Project respond to the extensive planning that has already been conducted in the South Boston Waterfront District. The Project is designed to extend the existing urban fabric into the new Seaport neighborhood and to create new urban connections and circulation. The Project includes vibrant new public spaces, such as new open spaces and pedestrian areas. The buildings within the PDA Area will provide massing design and design diversity that are sensitive to and complement the nearby historic neighborhoods and the new construction that will become part of the area. The Project promotes access to the Harborwalk and the waterfront, and will create a lively streetscape of stores, restaurants, and other vibrant uses.

## **VI. Approvals**

The Original Proponent filed a joint Project Notification Form under Article 80 of the Code and Environmental Notification Form (“**ENF**”) under the Massachusetts Environmental Policy Act (“**MEPA**”) on June 2, 2008, which requested a waiver of further review of Blocks A, H, and J. The BRA issued a Scoping Determination Waiving Further Review for Block A dated December 1, 2008. On August 8, 2008, the Secretary of the Executive Office of Energy and Environmental Affairs (the “**Secretary**”) issued a MEPA certificate on the ENF requiring a Draft Environmental Impact Report (“**EIR**”) and on September 17, 2008, the Secretary issued a Final Record of Decision granting a Phase 1

Waiver allowing commencement of Blocks A, H, and J of the Project prior to completion of the EIR. Due to changes in the placement of uses and other changes to Blocks H and J, a Notice of Project Change was filed with MEPA on March 31, 2009. On May 8, 2009, the Secretary issued a certificate on the Notice of Project Change reaffirming the scope contained in the August 8, 2008 certificate. A Final Amended Record of Decision was issued on June 5, 2009 confirming approval of commencement of Blocks A, H, and J prior to completion of the EIR. On October 17, 2008, the Secretary issued a Public Benefits Determination on the Phase 1 portion of the Project.

On November 30, 2009, the Original Proponent submitted a combined Draft EIR/DPIR for the Project. On February 26, 2010, the Secretary issued a Certificate on the Draft EIR requiring a Final EIR. On April 14, 2010, the BRA issued a Request for Additional Materials, and the Proponent filed Additional Materials with the BRA on June 4, 2010. The Original Proponent submitted a Final EIR on June 30, 2010. On August 13, 2010, the Secretary issued a Certificate on the Final EIR that determined that the Final EIR “adequately and properly complies” with MEPA, as well as a Public Benefits Determination.

The Original Proponent filed the Original Plan on April 23, 2010. The BRA approved the Original Plan on September 21, 2010 as Planned Development Area No.78. The Boston Zoning Commission approved the Original Plan on October 13, 2010, as well as a First Amendment to the PDA Plan on December 12, 2012, a Second Amendment on January 8, 2014, a Third Amendment on September 3, 2014, a Fourth Amendment on May 20, 2015, a Fifth Amendment on February 23, 2016, and a Sixth Amendment on May 18, 2016.

On February 7, 2017, the Proponent filed a Notice of Project Change (the “BPDA NPC”) under Article 80 of the Code with respect to the Remaining Blocks, and on February 28, 2017, the Proponent filed a Notice of Project Change with MEPA (the “MEPA NPC”). On April 7, 2017, the Secretary issued a Certificate on the NPC, requiring the filing of a Draft Supplemental Environmental Impact Report (“DSEIR”), and on June 23, 2017 the BPDA issued a Revised Scoping Determination on the 2017 NPC. On September 12, 2017, the Proponent filed a Supplemental Impact Report with the BPDA, and on September 15, 2017, the Proponent filed the DSEIR with MEPA.

## **VII. Location and Appearance of Structures**

The location and appearance of the buildings in the PDA Area will be generally consistent with the plans attached hereto as **Exhibit D**, but the architectural details of each building and the required public realm improvements associated with each development Block will be presented as part of the BPDA’s design review. Final plans and specifications for the Project will be submitted to the BPDA for certification as to consistency with this Plan.

The architectural design of the Project will continue to strive to achieve a balance of neighborhood cohesion, design diversity, and architectural quality that is imperative to the organic development of a neighborhood. The designs of the Project buildings will continue to employ a variety of scales, materials, and massing compositions to assure both a rich pedestrian environment and visual experience. The building materials will incorporate both traditional masonry recalling Boston’s architectural heritage, including stone and brick, and materials found in contemporary design, such as pre-cast concrete, metal, composite panels, and glass. Recycled and manufactured materials will be used when possible. The Project aims to allow the combination of diverse design approaches, as found in the architecture of the adjacent urban fabrics, yet maintain a clear notion of a continuous urban space and overall character of a forward-looking 21st century neighborhood.



## **VIII. Proposed Densities and Dimensions of Structures**

The Project consists of the buildings described on **Exhibit D**, which shall be in Substantial Accord with maximum Building Heights ranging from approximately 15 feet to up to 270 feet, measured in accordance with the Code, and as more specifically set forth on a Block by Block basis in **Exhibit D**. The Project will comply with the height and marking requirements of the Federal Aviation Administration.

**Exhibit D** provides conceptual designs for the Project buildings, and lists the maximum Building Heights, maximum Gross Floor Areas, and required street wall heights for each of the Blocks comprising the Project. **Exhibit H** shows planned setbacks. As used in this Plan, “Building Height” and “Substantial Accord” shall have the meaning set forth in Article 42E of the Code, and the Director of the BPDA may make a determination as to whether said meaning of “Substantial Accord” is met. “Gross Floor Area” shall have the meaning set forth in Article 2A of the Code. In acknowledgement of the likelihood that parking demand may decrease over the life of the Project buildings, in the event that the Proponent converts space within subsurface parking garages to uses constituting Gross Floor Area, such as Local Retail/Service Uses or General Retail Uses, or uses accessory thereto, the maximum Gross Floor Area shown on **Exhibit D** for the Block on which such garage is located shall be deemed automatically increased by the area of such converted space; provided however that such conversion shall be limited to the area of one floor of such parking garage.

Planned setbacks shown on **Exhibit H** are measured from the publicly-accessible improvements, such as sidewalks and pedestrian areas that currently exist or will be constructed within the PDA Area. **Exhibit H** shows planned street and sidewalk dimensions, but the final dimensions and design of such streets and sidewalks, and other publicly-accessible improvements, will be subject to BPDA Design Review and the approval required of the City of Boston and other public agencies.

Subject to the approval of the BPDA, unused Gross Floor Area allowed on one Block may be accommodated on another Block in the same Project Component as long as the total Gross Floor Area for that Project Component does not exceed the total maximum Gross Floor Area listed on **Exhibit D** for the Blocks in that Project Component. Buildings shall be in compliance with this Plan provided that their Gross Floor Areas do not exceed by more than ten percent (10%) the maximum Gross Floor Areas approved by this Plan for each Project Component. Overall PDA Area-wide Gross Floor Area will not exceed 7,723,110 square feet. Proposed changes to Gross Floor Area that exceed the above-referenced 10% for any given Block will require an amendment to this Plan providing an amended **Exhibit D** to this Plan demonstrating consistency with the overall distribution of Gross Floor Area. Issuance of a Certificate of Consistency pursuant to Section 80C-8 of the Code shall conclusively establish consistency with the maximum Gross Floor Areas approved by this Plan.

## **IX. Uses**

All or portions of Blocks D, F, G, L3, L4, L5, L6, N, and P are currently used for surface parking, and such use on these Blocks will be allowed until development commences on each of these Blocks in accordance with this Plan. Prior to the construction of permanent buildings on each of the Remaining Blocks, temporary uses, events, performances, and programming that will enhance the pedestrian experience in the Project Area, including temporary Retail/Entertainment/Restaurant/Service Uses, and Innovation Uses, as hereinafter defined, shall be allowed.

The Project is being developed as a mixed use project. **Exhibit E** lists the uses that this Plan approves for each Block. In addition to the uses described on **Exhibit E**, uses allowed by underlying zoning are allowed within the PDA Site. Material deviations from the uses listed on **Exhibit E** shall

require the approval of the BPDA's Board of Directors and an amendment to this Plan. **Exhibit F** lists the allowed uses and use categories for the PDA Area, which uses are allowed as either main, accessory, or ancillary uses, provided that the uses are approved pursuant to **Exhibit E** or as otherwise provided in this paragraph. The Accessory and Ancillary Uses listed on **Exhibit F** are allowed for individual Blocks if they are accessory or ancillary to a main use allowed by **Exhibit E** or otherwise provided in this paragraph. Notwithstanding anything in this Plan to the contrary, in order to promote the Seaport's development as a major destination for artistic and cultural events, Civic/Community Uses and Cultural Facilities are allowed on every Block within the Project.

The entire Project's program, character and uses are required to support the development of Boston's innovation economy. The ground floors of the Project buildings on Blocks B, C, D, F, G, K, L, M, N, and P will contain publicly-accessible uses listed in the use category Retail/Entertainment/Restaurant/Service Uses on **Exhibit F**. Retail and Services uses will be included in the Project as both main uses and as ancillary and accessory uses. The placement and maintenance of rooftop wireless communications and other telecommunications equipment such as antennae, dishes, equipment mounting, and equipment mounting structures shall be allowed, subject only to design review by the BPDA.

The minimum day care requirements of Section 42E-21.1 have been satisfied for the Project, and shall not apply to the Remaining Blocks. Any day care facilities provided within the Project to comply with the requirements of Section 42E-21.1 shall not be included in the calculation of Gross Floor Area.

#### **X. Open Space and Landscaping**

The Project will provide a substantial amount of open space and landscaping, consistent with **Exhibit C**, which will help create a continuous public realm. At Project completion, approximately 39% (approximately 9.2 acres) of the Project Site (as defined in Section III of this Plan) will be dedicated to streets, sidewalks and other Public Open Space,<sup>1</sup> and approximately 34% (7.8 acres) of the Project Site will be Open Space as defined in Article 42E to exclude the vehicular portions of streets (sidewalks, streets and private ways open only to pedestrians and emergency vehicles are included).<sup>2</sup> As described in more detail in Section XV, the Project will include three new major open spaces, Seaport Common on Block F (already constructed); Harbor Square park within the L Blocks; and Sea Green on Block Q (already constructed). The locations of Project open spaces are shown on **Exhibit C**. In addition, the Project includes open space areas for pedestrians, including Courthouse Square, located along Northern Avenue and across from the Moakley Federal Courthouse, and the Summer Street Steps adjacent to Blocks N and P, and Harbor Way and Harbor Square park, which will provide a wide pedestrian-oriented promenade between Congress Street and Northern Avenue. An intimate, retail-lined pedestrian piazza will be created at the center of the M-Blocks, which will also provide pedestrian pathways through this block between East Service Road and B Street along the Autumn Lane axis. Another pedestrian area has been constructed at the Seaport Boulevard end of Farnsworth Street, as shown on **Exhibit C**. The Original Proponent also contributed to the improvement of Parcel E (as designated in the South Boston Municipal Harbor Plan) at the Children's Wharf Park outside of the PDA Area, in accordance with the SBMHP. Parcel E is now planned as a key element of the new Martin's Park,

---

<sup>1</sup> Pursuant to Article 2A of the Code, "Public Open Space" is "an open space in public ownership devoted or to be devoted to a public use with only minor accessory buildings, if any. No structure that exceeds twenty feet in height or two thousand square feet in Gross Floor Area shall be considered to be a part of such public open space. 'Public open space' shall be construed to include a street." The Proponent intends to permanently dedicate these areas to the above described public uses, thereby meeting the intent of the Code definition, even if not all such areas will be in public ownership.

<sup>2</sup> This calculation of Open Space may include areas described in Section 42E-6 (x) and (y) of the Code without the need for the Board of Appeal to grant any exceptions pursuant to Section 6A of the Code.

honoring Martin W. Richard. Old Sleeper Street, which is adjacent to Block A, was constructed by the Block A developer to create a long-awaited pedestrian connection between existing Harborwalk segments.

Along Seaport Boulevard, the Project will provide new tree plantings, a landscaped median, and sidewalk paving, as shown on **Exhibit C**. A wide sidewalk with a double row of trees is planned for the north side of Seaport Boulevard to accommodate outdoor seating and sidewalk entertainment; those improvements have already been installed at Blocks B, C, and F. A wide sidewalk with a single row of trees has been installed on the south side of Seaport Boulevard at Blocks H, J, K, and L1, and is planned for Block L2.

The final design and specific materials of all public improvements will be subject to the approval of the BPDA.

## **XI. Proposed Traffic Circulation**

Three major east-west streets serve the PDA Area. Northern Avenue is a two-way local roadway with two lanes in each direction. Seaport Boulevard runs two-way, with two lanes in each direction with a raised median. Congress Street also runs two-way, with two lanes in each direction. There are five north-south streets directly serving the PDA Area. Farnsworth Street is a local street running north from Congress Street; the Proponent has constructed a plaza at the northern terminus of Farnsworth Street on land owned by the BPDA to provide a pedestrian path to Seaport Boulevard, across from Courthouse Square. Thomson Place, a local street running from Congress Street north to Seaport Boulevard, is aligned with Fan Pier Boulevard on the other side of Seaport Boulevard. Boston Wharf Road consists of two southbound lanes; the Proponent intends to widen/re-stripe Boston Wharf Road to accommodate buffered bike lanes. East Service Road is a one-way northbound street located south of Seaport Boulevard, providing two travel lanes. Pier 4 Boulevard is the continuation of East Service Road running north/south to the north of Seaport Boulevard. B Street provides two travel lanes in each direction, with a raised median.

The traffic study performed by the Proponent was included in the 2017 NPC as Section 3. The Project's proposed vehicular and pedestrian circulation patterns are depicted on the Circulation Plan attached as **Exhibit G**. Prior to the commencement of construction of any Project Component, the Proponent or Project Component owner shall enter into a Transportation Access Plan Agreement for that Project Component with the Boston Transportation Department, which shall require the mitigation measures described in the DPIR and the BPDA NPC and any additional mitigation measures deemed necessary for the Project Component. The Proponent or the owner of a Project Component shall provide updated roadway and transit monitoring including traffic monitoring, transit ridership and occupancy monitoring as appropriate for assessing Project traffic and transit impacts in the South Boston Waterfront District following the construction and occupancy of 3 million square feet and 5 million square feet. The Proponent or Project Component owner will be required to provide additional roadway and transit mitigation based on the result of such monitoring, which shall address any traffic conditions caused by previous Project Components and not anticipated in either the DPIR or 2017 NPC.

The Project will result in the creation of additional new streets and new extensions of existing streets, some of which have already been constructed, and all of which are shown on the Circulation Plan. Autumn Lane will create a new east-west connection across the PDA Area between East Service Road, Boston Wharf Road, and Stillings Street. Harbor Way will serve as a lively pedestrian connection from Summer Street to Northern Avenue and beyond. Thomson Place is intended to be opened from the Fort Point Channel Landmark District to Seaport Boulevard, and Fan Pier Boulevard provides a north-south connection from Seaport Boulevard through to Northern Avenue. In addition, several new

pedestrian passage ways will be created throughout the district, as shown on the Circulation Plan and described in Section XV(c) below. All streets will be constructed to City of Boston standards and requirements.

The creation of this enhanced circulation system will result in enhanced accessibility of the PDA Area to pedestrians and vehicles alike. These new roadway and pedestrian way improvements, combined with the existing streets providing access to the PDA Area, will allow adequate north-south and east-west vehicular and pedestrian access to and within the PDA Area. These connections will enhance pedestrian travel between the Project and other important destinations such as the Moakley Federal Courthouse, the Children's Museum, the Institute of Contemporary Art, the Fan Pier Water Transportation terminal, South Station, and the Harborwalk.

## **XII. Parking and Loading**

The Project will include up to approximately 5,500 spaces of below-grade parking, depending on the final mix of uses, which is a reduction from the 6,375 spaces described in the Original Plan. All parking spaces will be subject to the South Boston parking freeze regulations and require parking freeze permits or exemptions from the Air Pollution Control Commission on a Project Component basis. There will also be approximately 65 new on-street, short-term parking spaces, for a total of approximately 200 on-street spaces within the PDA Area.

Planned parking and loading locations are shown generally on **Exhibit I**; specific parking and loading locations and layouts, which may include mechanical parking stackers, will be developed in consultation with the Boston Transportation Department and included in Transportation Access Plan Agreements and Construction Management Plans for each Project Component and will be deemed consistent with this Plan once this process is complete for each Project Component.

## **XIII. Public Transportation**

The PDA Area is within one-half mile (a 10-minute walk) of South Station, a transportation hub that provides access to the MBTA Red Line, Silver Line, and eight commuter rail branches. South Station is also the terminus for Amtrak train service along the Northeast Corridor. Greyhound, Peter Pan, and others provide regional and commuter bus service from South Station. Several smaller bus companies have recently introduced service between Boston and New York as well. In addition, the existing MBTA Silver Line Courthouse station entrance is within the PDA Area, and the Project includes the construction of a new head house on Block F. The MBTA Silver Line World Trade Center station is located in close proximity to the PDA Area. Several MBTA local and express bus routes operate near the PDA Area, and numerous private shuttles serve the PDA Area with routes to North Station and South Station. It is anticipated that such private shuttle services will expand to serve additional demand from future employment density in the South Boston Waterfront District, providing further transportation options for commuters to and from the PDA Area.

Weekday bus and subway service is provided between approximately 5:00 a.m. and 1:00 a.m. Actual service times vary by route or line.

The Proponent shall provide updated monitoring of Silver Line transit service and ridership once 3 million square feet and 5 million square feet of Gross Floor Area have been constructed and occupied, as described in Section XI of this Plan.

#### **XIV. Pedestrian and Bicycle Circulation**

The extension of the local street and sidewalk grid into the PDA Area will provide pedestrian access throughout the PDA Area. The completed improvements to Old Sleeper Street have made a direct connection with the open space and Harborwalk at the Moakley Federal Courthouse, allowing a continuous waterfront walk to the Financial District and beyond. The construction of a pedestrian way, called Harbor Way, from Summer Street through Harbor Square park and across Northern Avenue, will create legible and inviting access from the Boston Convention and Exhibition Center and the entire area south of Summer Street to the waterfront. The Project will also contain generous pedestrian sidewalks, bike lanes and bike racks for bicycle commuters. Protected bicycle lanes will be created by the Project on Seaport Boulevard and other major routes through the Project Area, subject to approval by the Boston Transportation Department, the Public Improvement Commission, and other City of Boston agencies. Specific pedestrian sidewalks, bike lanes, and bike rack layouts will be developed in consultation with Boston Transportation Department and the BPDA for each Project Component and once approved by both the Boston Transportation Department and the BPDA will be deemed consistent with this Plan. Pedestrian and bicycle improvements will be subject to required approvals from of the City of Boston Public Improvement Commission.

#### **XV. Public Realm Improvements**

The Project will provide the following public realm improvements in conjunction with the development of individual Blocks, as shown on **Exhibit C**. The final dimensions, design, and construction of each of the improvements described below shall be subject to the BPDA's Design Review, and the final approvals and issuance of permits from other public agencies as required.

##### **a. Open Space**

i. *Seaport Common [current approximate area 36,000 sf (already constructed); to be expanded to approximately 40,000 sf in conjunction with construction of future Block F building]:* Seaport Common, which includes District Hall (known as the Innovation Center in the Original Plan), the Massachusetts Fallen Heroes Memorial, and other open space improvements, has already been constructed on Block F. The Proponent will complete other improvements to Seaport Common in connection with the construction of the building planned for Block F. Subject to MBTA agreement, the Proponent will construct a new MBTA Silver Line head house (the "Silver Line Head House") at the southwestern corner of the Common.

ii. *Harbor Square park [approximate area 66,000 sf]:* A new open space within the L Blocks ("Harbor Square park"), will contain approximately 1.51 acres of public open space, with dramatic and inviting landscaping features. The Harbor Way linear public open space through the Project Area will be anchored by a café- and restaurant-lined multi-use public open space called Harbor Square park located on Blocks L3-L6. The central space within Harbor Square park will be richly landscaped, and is currently planned to contain a children's recreational play area, a flower garden, and one or more major public art installations.

iii. *Seaport Boulevard:* The Proponent will improve Seaport Boulevard with new tree plantings, new lighting, a landscaped median, and distinctive sidewalk paving (the "Seaport Boulevard Improvements"). A double row of trees is planned for the north side of Seaport Boulevard, to accommodate outdoor seating, public art, kiosks, sidewalk entertainment, and other streetscape improvement and activation. A wide sidewalk with a single row of trees is

planned for the south side. Protected bicycle lanes are contemplated along most of the length of Seaport Boulevard between Sleeper Street and East Service Road/Pier 4 Boulevard.

iv. Courthouse Square [approximate area 17,000 sf – already constructed]: Courthouse Square is an outdoor public space connecting Seaport Boulevard with Northern Avenue between the buildings on Blocks B and C, and across from the Moakley Federal Courthouse.

v. Sea Green (Block Q Recreational Area) [approximate area 30,470 sf – already constructed]: The Original Proponent constructed a new open space on Block Q (“Sea Green”), which promotes active recreational uses and play areas. Block Q is a part of the Early Action Public Benefits described in Section XVIII. The Project may construct a pavilion-type structure within Sea Green providing ancillary services to the open space area; such structure will be dimensionally consistent with the definition of Public Open Space as defined in Article 2A.

vi. Summer Street Steps [approximate area 14,500 sf]: The Project includes the construction of a new public grand stair adjacent to Blocks N and P (“Summer Street Steps”). The steps will provide a pedestrian and bicycle connection between the elevated Summer Street and Congress Street, and connect to Harbor Way at a mid-block crosswalk across Congress Street. The Proponent will provide an accessible route along with the construction of the steps. A performance plaza is currently planned at the bottom of the steps to provide an outdoor venue for performance art.

vii. Children’s Wharf Park/Harbor Plan Parcel E: The Original Proponent contributed to the improvement of Parcel E (as designated in the South Boston Municipal Harbor Plan) at the Children’s Wharf Park outside of the PDA Area, in accordance with the SBMHP and as part of the Early Action Public Benefits described in Section XVIII. Parcel E is now planned as a key element of the new Martin’s Park.

b. Local Streets

i. North/South Streets. In the north/south direction, a vehicular connection is planned when Thomson Place is extended from the Fort Point District to Seaport Boulevard (the “Thomson Seaport Extension”) on land owned by the MBTA. A new connection to Fan Pier Boulevard between Seaport Boulevard and Northern Avenue has been constructed in conjunction with the completion of Block C (the “Fan Pier Boulevard Extension”) on property owned by the Proponent.

ii. East/West Streets. In the east/west direction, the Seaport Boulevard Improvements will create a grand urban boulevard connecting Boston’s Financial District to the Boston World Trade Center, Waterside Place, and Commonwealth Flats. The new Autumn Lane roadway, running between Boston Wharf Road and Pier Four Boulevard (“Autumn Lane”), provides a pedestrian and vehicular connection between these major north-south axes and will also provide loading and service access to Blocks L1, L2, L3, L4, and L6. A new street has been constructed between Boston Wharf Road and Stillings Street (“Stillings Extension”) to connect the Fort Point Channel Landmark District with the Project Area and points beyond.

c. Pedestrian Plazas/Ways

- i. Courthouse Square. The developer of Blocks B and C has completed a large public pedestrian space connecting Seaport Boulevard and Northern Avenue between Blocks B and C and linking to Courthouse Square plaza at its northern end.
- ii. Farnsworth Street Pedestrian Link. In conjunction with the development of Block J, the Proponent and the Block J owner have constructed a publicly-accessible pedestrian plaza from the northern terminus of Farnsworth Street through to Seaport Boulevard, which aligns with Courthouse Square and provide a pedestrian connection to Northern Avenue, the Moakley Federal Courthouse and the Fan Pier development beyond.
- iii. Pedestrian Connections Within Block L. In addition to being part of the Harbor Way north-south pedestrian corridor, Harbor Square park will be configured to provided generous pedestrian connections to Boston Wharf Road to the west and East Service Road to the east, which will be constructed within Blocks L3, L4, L5, and L6, as shown on Exhibit C.
- iv. Harbor Way: The Project will include a major new pedestrian connection extending north from Congress Street to Northern Avenue.
- iv. M Way: The developer of Blocks M1 and M2 will construct M Way, a pedestrian way through the M Block connecting East Service Road and B Street, passing through a large pedestrian courtyard lined with retail and restaurant uses.
- v. Old Sleeper Street. Old Sleeper Street has been improved by the development of Block A to create a pedestrian way providing a connection between existing Harborwalk segments at the Children’s Museum and the Moakley Federal Courthouse. The improvements accommodate loading and maintain required access to the Barking Crab restaurant and associated marina.
- vi. Summer Street Steps. Between Blocks N and P, the Proponent will construct public steps and an accessible route from Congress Street to Summer Street.
- vii. Northern Avenue Improvements: In addition to the reconstruction of sidewalks and the introduction of new lighting and landscaping, the Proponent will improve the vehicular portions of Northern Avenue in conjunction with the development of Blocks B, C, D, F, and G. Improvements will range from the full-depth pavement reconstruction of certain street sections, to the mill and overlay of other sections (the “Northern Avenue Improvements”). The entirety of Northern Avenue adjacent to Blocks B-G will be re-stripped in connection with the development of each Block. All such work will be subject to the approval of the Public Improvement Commission and other regulatory agencies.
- viii. Interim ICA/Fan Pier Pedestrian Connector: The Original Proponent constructed an interim pedestrian connector between its Northern Avenue and Seaport Boulevard parking lots (the “Interim ICA Connector”), which provided easy pedestrian access to the Institute of Contemporary Art prior to construction on individual Blocks. The Interim ICA/Fan Pier Pedestrian Connector was one of the Early Action Public Benefits described in Section XVII and was completed and subsequently replaced by pedestrian connections through Block F.
- ix. Block K Open Corner [approximate area 600 sf – already constructed]: The developer of Block K constructed an open space area on the southwest corner of Seaport

Boulevard and Boston Wharf Road, extending the sidewalk and creating an open space cut out from the building's massing at the ground level (up to 20 feet in elevation).

x. Block H-1 Plaza [approximate area 2,160 sf – already constructed]: In conjunction with the completion of the chapel on Block H (described below), a pedestrian plaza has been constructed on the east end of Block H, adjacent to Sleeper Street.

d. Civic/Community and Innovation Space

The following items i-iv are the currently planned civic space. If changes are proposed to these spaces, then the Proponent shall be required to provide an equivalent civic space substitute subject to BPDA approval.

i. Civic Space on Block D [minimum area 5,000 sf]. The Proponent will construct civic space ("Civic Space") within Block D.

ii. Visitor Center on Block A [minimum area 2,000 sf]: The developer of Block A included a new visitors' center ("Visitor's Center") within the building on Block A, to provide information about the Seaport District.

iii. Performing Arts Uses: The Proponent will seek to include performing arts uses in the form of the Seaport Performing Arts Center ("SeaPAC") within the Block P building and/or other Blocks. This performing arts space or spaces could be used by local arts institutions, and could provide a new venue for performances to be enjoyed by both tourists and locals. Three Performing Arts venues are currently planned for the Project, with a combined total seat count of approximately 750 seats. The Proponent's provision of such space is dependent on local demand and funding.

iv. Cultural/Educational Space on Block G [minimum area 5,000 sf]: The Project will include approximately 5,000 square feet of cultural and/or educational space on Block G.

v. Innovation Center on Block F [approximately 12,000 sf – already constructed]: The Original Proponent constructed, and the current Proponent owns and leases to an innovation center operator an innovation center building, called District Hall, on Block F (the "Innovation Center"). Such lease has a term that expires on June 5, 2023 (the "Innovation Center Initial Lease Period"). The construction of the Innovation Center was an Early Action Public Benefit as described in Section XVII. Following the expiration of the Innovation Center Initial Lease Period, the Proponent will continue to operate the Innovation Center for an additional period of at least ten (10) years. The Innovation Center, and subsequent structures and uses on Block F, may include electronic signs, as depicted on Exhibit J hereto or otherwise approved by the BPDA.

e. Catholic Chapel

A new facility has been constructed on Block H to house the Our Lady of Good Voyage Chapel, previously located on Block D (the "New Chapel").



## **XVI. Other Public Benefits**

The following public benefits will be provided with the construction of each Block, as applicable:

### **a. Increased Housing.**

The Project includes the development of approximately 3,200 residential units, including both for sale and rental units, including:

1. **Affordable Housing.** The Project intends to set aside at least 15% of the number of market rate units as affordable units under the Mayor's Inclusionary Development Policy housing program (the "**IDP**"), governed by one or more Affordable Housing Agreements with the BPDA ("**Affordable Housing**"). Each Project Component that includes Residential Uses ("**Residential Block**") shall provide the required Affordable Housing units on-site, or the Proponent may redistribute the Affordable Housing units to other Blocks subject to the approval of the BPDA. The first 2,500 units developed within the Project shall be subject to the IDP in effect at the time of the BPDA's approval of the original Project in 2010. The remaining approximately 700 units shall be subject to the IDP as subsequently amended. Subject to the approval of the BPDA, the Proponent may satisfy the affordable housing requirement for individual residential buildings in whole or in the part through the construction of income-restricted units reserved for BPDA-certified artists.
2. **Innovation Housing.** In addition to the number of affordable housing units described above, additional units equal to a minimum of 15% of the number of market rate units are proposed as innovation and workforce housing units. Innovation Housing may include smaller unit sizes, flexible unit layouts, combined living and working spaces, shared common areas and other design features to increase affordability and communication among residents ("**Innovation Housing**"). Each Residential Block shall provide the required Innovation Housing Units on-site, or the Proponent may redistribute the Innovation Housing Units to other Blocks subject to the approval of the BPDA.

Each Residential Block shall comply with the requirements of paragraphs 1 and 2 above by providing the specified number of units in the PDA Area, or with the approval of the BPDA, off-site or through making an equivalent monetary contribution to affordable housing, or the Proponent shall amend this Plan in accordance with Section 80C of the Code.

### **b. Economic Benefits.** The Project will generate significant economic activity and will create specific economic benefits to the City of Boston.

- i. **New Tax Revenue.** At full build-out, the Project is expected to generate approximately \$50,000,000 in annual property taxes, and approximately \$31,000,000 in annual sales taxes.
- ii. **Jobs.** The Project is expected to create approximately 12,000 construction jobs and approximately 23,000 permanent jobs. The permanent jobs will be created through the retail stores, office and research uses, hotels, and services related to the residential uses.

- iii. Linkage. The Project is expected to generate approximately \$41,500,000 in housing and jobs linkage funds to the City of Boston. As required by Section 80B-7(3)(a) of the Code, the Original Proponent entered into a Development Impact Project Agreement with the BRA (the “Master DIP Agreement”), and individual development Block owners have entered into individual Development Impact Project Agreements to effectuate the terms of the Master DIP Agreement. As set forth in the Master DIP Agreement, linkage rates with respect to the total amount of Gross Floor Area permitted under the Original Plan shall be at the rate set forth in the Master DIP Agreement. The Housing Contribution Grant rate and the Jobs Contribution Grant rate with respect to the additional total amount of Gross Floor Area permitted by this Amended Plan shall be \$8.34 and \$1.67 per square foot of Gross Floor Area of Development Impact Uses, respectively.

## **XVII. Other Requirements**

### a. Sustainable Design/Green Building.

#### i. Green Building

The Project will comply with the requirements of Article 37, Green Buildings, of the Code. The Project team will use the appropriate U.S. Green Building Council’s Leadership in Energy and Environmental Design (“LEED”) green building rating system to evaluate sustainable design measures, in accordance with Article 37 of the Code. The LEED-NC or LEED-CS rating system will be pursued as applicable for the different use types within the Project for all buildings larger than 25,000 square feet of Gross Floor Area. Individual buildings will pursue LEED Certification at a target rating level of Silver. In addition, the Project as a whole has achieved LEED-ND Stage II Gold Certification for the master plan.

#### ii. Energy

A Project energy plan shall be submitted for any Project Component prior to the final permitting approval of said Project Component in accordance with BPDA Development Review Procedures. The Project energy plan will document the use of innovative energy technologies by detailing any clean energy (including any cogeneration) technologies and/or renewable energy planned for installation (including proposed capacity and/or percentage of project energy demand generated by the clean/renewable technologies) within the Project Component.

#### iii. Climate Change Adaptation

Each Project Component shall comply with applicable State and City strategies for addressing sea-level rise and climate change. The portions of the Project within the FHSPOD will comply with the provisions of Article 25 of the Code.

### b. Groundwater Conservation

Portions of the PDA Area are located within the GCOD, governed by Article 32 of the Code. Article 32 requires that projects meeting certain criteria employ mitigation measures to avoid adverse impacts to groundwater levels. The Project is subject to Article 32 because it will construct structures where the new extensions will occupy more than fifty (50) square feet of lot area.

Based on its location in South Boston, only the requirements of Section 32-6(b) of the Code apply to the portions of the PDA Area that are within the GCOD. Under that section, the Project Components within the GCOD must demonstrate that they will result in no negative impact on groundwater levels in the PDA Area or adjacent lots, subject to the terms of any (i) dewatering permit or (ii) Cooperation Agreement entered into by the Proponent and the BPDA.

The portions of the Project within the GCOD will comply with the applicable standards set forth in Section 32-6(b) of the Code by resulting in no negative impact on groundwater levels within the PDA Area or on adjacent lots. If necessary, the Proponent or the owner of any Block within the GCOD will incorporate systems into any project within the GCOD that meet the groundwater conservation standards set forth in Section 32-6(b). The Proponent or Block owner will obtain written confirmation from such project's civil engineer that said standards are satisfactorily met, and will provide a copy of this letter to the BPDA and to Boston Groundwater Trust prior to the issuance of a Certificate of Consistency. Compliance with this Plan shall constitute compliance with Article 32 without the necessity of the Project obtaining a conditional use permit pursuant to Article 32.

### **XVIII. Phasing Plan and Current Development Timeline**

The Project has been conceived and planned with a flexible mixture of complementary and mutually reinforcing uses. Project phasing is intended to provide certainty that the full build-out can be achieved over time, which is key to the Project's feasibility. Current Project plans for the development of the Remaining Blocks anticipate beginning construction on the first such Blocks in 2018, with construction completion of the Remaining Blocks scheduled for 2023 at the earliest. This Plan constitutes approval of the development of the PDA Area in multiple phases or sub-phases, which phases or sub-phases may proceed sequentially or simultaneously.

The Original Plan anticipated the construction of "Early Action Public Benefits" (as listed below). Those commitments, which are as follows, have been completed by the Original Proponent:

#### **EARLY ACTION PUBLIC BENEFITS**

1. Innovation Center (Block F)
2. Parcel E Improvements
3. ICA/Fan Pier Interim Pedestrian Connector
4. Block Q Recreational Area

Construction of individual Blocks may proceed as part of, or separate from, other Blocks listed in the same groupings below, so long as the Proponent constructs the public realm improvements described in Section XV above in conjunction with the Blocks with which such improvements are associated pursuant to **Exhibit E**. With respect to any mitigation commitments not clearly linked to a specific Block on **Exhibit E**, if not all of the construction for a Project Component will be completed in one continuous building sequence, the Proponent will propose, subject to the approval of the BPDA, an allocation of mitigation commitments that reasonably reflects the *pro rata* portion attributable to an individual Project Component that also identifies how the remaining public improvements will be allocated and completed. The Individual Blocks will also be subject to any conditions set forth in Chapter 91 licenses for such Blocks within Chapter 91 jurisdiction.

It is contemplated that within the PDA Area, the Project Components may each be separately owned and financed, including through one or more condominium structures. As used herein, “Proponent” shall mean the Proponent named above or, with respect to any Project Components subsequently owned by another entity, such successor in interest. This Plan constitutes approval for any subdivision, re-subdivision, or condominium creation, provided that the Proponent (or its successors in interest) shall give written notification to the BPDA’s Director of any such subdivisions, re-subdivisions, or condominium creation, and assignments of responsibilities.

Compliance of Project Components with the requirements of this Plan shall be determined based on each Project Component’s compliance with the requirements of this Plan that apply to such Project Component, including the provision of public benefits associated with such Project Component on **Exhibit E**. Each building will be eligible to receive its own Certification of Consistency or Partial Certification of Consistency. With respect to the Developed Blocks, in no event shall changes to the Original Plan approved in this Plan be deemed to create any non-compliance with this Plan, or to create any other zoning non-conformities.

### **XIX. Development Review Procedures**

The Project is subject to Large Project Review under Section 80B of the Code. Final plans and specifications for any portion of the Project shall be subject to review and approval by the BPDA in accordance with its Development Review Procedures. Because the Project is a phased project on which design development will proceed sequentially, it is anticipated that final development review will occur at different times for separate Project Components.

The BPDA has approved the conceptual plans attached hereto as **Exhibit D**, and has issued Certifications of Consistency and Certifications of Compliance with respect to certain of the Developed Blocks. The BPDA’s approval of final plans and specifications shall confirm their consistency with this Development Plan and with any applicable design requirements set forth in the underlying zoning regulations for the M-4 Restricted Manufacturing Subdistrict, the I-2 Industrial Subdistrict, and Article 42E of the Code, as applicable. Given the scope of the proposed Project, and in light of the various reviews of the Project necessary to secure all required permits and approvals, the Proponent may seek to modify the Project. Proposed minor modifications to Project site improvements, exterior facades, roofscapes, setbacks, architectural features, public spaces, roadway and transit mitigation, or parking and loading are allowed subject only to BPDA Design Review approval, without requiring an amendment to this Development Plan or further BRA action.

### **XX. Applicability**

In accordance with Section 80-C of the Code, consistency of the Project with this Plan constitutes compliance with the dimensional, use and all other requirements of the Code to the extent such requirements have been addressed in this Plan. This Plan shall constitute permanent zoning for the PDA Area, within the meaning of the South Boston Municipal Harbor Plan (as applicable). To the extent that any aspect of proposed uses and proposed structures addressed in this Plan are in conflict with any requirement of the Code, this Plan shall govern.

### **XXI. Amendment of Plan**

Any owner of an individual Project Component may seek amendment of this Plan only as to such Project Component in accordance with the procedures prescribed by the Code without the consent of any other owner of a Project Component, provided, however, that no such amendment shall affect the obligations of the Proponent under any agreements between the Proponent and the BPDA. In the event

that any amendment to this Plan proposed by the owner of a Project Component is approved, and such amendment affects the overall compliance of the Project with this Plan, this Plan shall be deemed amended with respect to the Project as a whole to the extent necessary for the overall Project to comply with this Plan.

**XXII. Miscellaneous**

Unless otherwise set forth herein, all references to terms set forth in the Code shall have the meaning set forth in the Code, as amended to the effective date hereof, and not as the same may be amended hereafter.

**EXHIBITS:**

- Exhibit A: Legal Description
- Exhibit B: PDA Area Plan
- Exhibit C: Public Realm Improvements
- Exhibit D: Block Plans
- Exhibit E: Proposed Phasing, Planned Uses, Public Realm Improvements and Benefits
- Exhibit F: Permitted Uses
- Exhibit G: Transportation Circulation
- Exhibit H: Proposed Street Dimensions
- Exhibit I: Parking and Loading

EXHIBIT A  
LEGAL DESCRIPTION

**PLANNED DEVELOPMENT AREA DESCRIPTION  
SEAPORT SQUARE**

The Limits of Seaport Square Planned Development Area are bounded and described as follows:

Beginning at the point of intersection of a line that is about 21 feet north of the northerly line of Block G and 18 feet east of the easterly line of Block G;

Thence running southwesterly about 18 feet east of the easterly line of Block G to a point about 22 feet north of the southerly line of Seaport Boulevard;

Thence running easterly about 22 feet north of Seaport Boulevard to a point about 22 feet easterly of B Street;

Thence running southerly about 22 feet east of B Street to a point 24 feet south of the northerly line of Congress Street;

Thence running southwesterly about 24 feet south of the northerly line of Congress street to a point on the easterly sideline of Air Rights Block P;

Thence running southwesterly along the easterly sideline of Air Rights Block P;

Thence running northwesterly along the southerly sideline of Air Rights Block P;

Thence running southerly about 58 feet east of the westerly sideline of East Service Road to a point 9 feet south of the southerly line of summer street;

Thence running northwesterly about 9 feet south of the southerly line of summer street to a point 11 feet west of the easterly line of West Service Road Extension;

Thence running northeasterly about 11 feet west of the easterly line of West Service Road Extension over Congress Street, and continuing northeasterly about 10 feet west of Boston Wharf Road to a point;

Thence running northwesterly by the southerly sideline of Block Q to a point 11 feet west of the easterly sideline of Stillings Street;

Thence running northeasterly 11 west of the easterly sideline of Stillings Street to a point at the sideline of Block K;

Thence running northwesterly by the southerly lines of Block K, MBTA, Block J, BRA, and Block H to a point 24 feet west of the easterly line of Sleeper Street;

Thence running northeasterly to a point 13 feet south of the northerly sideline of Seaport Boulevard to a point;

Thence running northwesterly 13 feet south of the northerly sideline of Seaport Boulevard to a point 41 feet west of the westerly line of Block A;

Thence running northeasterly 41 feet west of the westerly line of Block A to a point 60 feet north of the southerly sideline of Northern Avenue;

Thence running southwesterly in Northern Avenue to a point 20 feet north of the southerly sideline of Northern Avenue and 10 feet east of the westerly sideline of Sleeper Street;

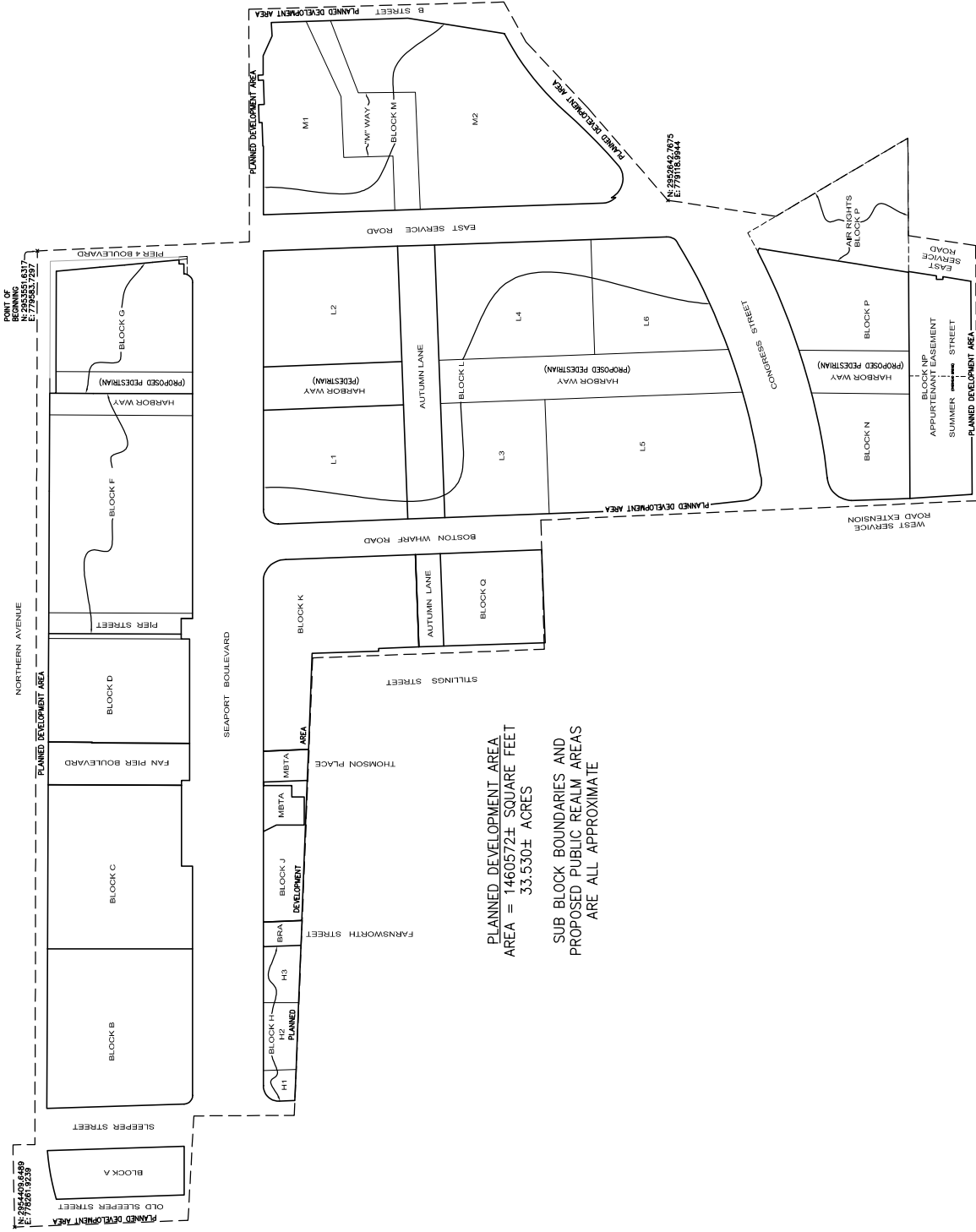
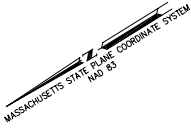
Thence running southeasterly 20 feet north of the southerly sideline of Northern Avenue to the point of beginning.

Together with any fee or easements that Proponent has or may acquire from MassDOT with respect to Air Rights Block P.

The above described Planned Development Area contains approximately 1,460,572 square feet (approximately 33.5 acres) and is shown on the plan titled "Planned Development Area, Seaport District South Boston, Boston, Massachusetts" dated September 2017, prepared by Nitsch Engineering.

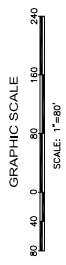


EXHIBIT B  
PDA AREA PLAN



PLANNED DEVELOPMENT AREA  
 AREA = 1460572± SQUARE FEET  
 33.530± ACRES

SUB BLOCK BOUNDARIES AND  
 PROPOSED PUBLIC REALM AREAS  
 ARE ALL APPROXIMATE



POINT OF  
 NAD 83  
 E: 2983351.637  
 E: 7795837.297

N: 2525642.7075  
 E: 7781618.8444

N: 2525409.6589  
 E: 7782618.2529

PLANNED DEVELOPMENT AREA  
 SEAPORT DISTRICT SOUTH BOSTON  
 BOSTON, MASSACHUSETTS

PREPARED FOR:  
 SEAPORT SQUARE DEVELOPMENT COMPANY, LLC  
 33 BOYLSTON STREET, CHESTNUT HILL, MA 02467

REV.	COMMENTS	DATE

SUBJECT: A. 1460	RM
FILE: 13149_PDA_460	RM
SCALE: 80'	RM
DATE: SEPTEMBER 2017	RM
FIELD BOOK: N/A	RM
DRAWN BY: RM	RM
CHECKED BY: RM	RM

- Civil Engineering
- Land Surveying
- Structural Engineering
- Green Infrastructure
- Planning
- GIS

**www.nitsch.com**  
 2 Center Plaza, Suite 430  
 Boston, MA 02108  
 T: (617) 338-0063  
 F: (617) 338-6472



EXHIBIT C  
PUBLIC REALM IMPROVEMENTS



**Major Public Open Spaces**

- 1 Seaport Common (F)
- 2 Harbor Square Park (L3-L6)
- 3 Courthouse Square (B+C)
- 4 Sea Green (Q)
- 5 Summer Street Steps and Plaza (N+P)
- 6 Block M Courtyard (M)
- 7 Harbor Way (F+G)
- 8 Old Sleeper Street (A)
- 9 H-1 Plaza (H)
- 10 Farnsworth St. Pedestrian Link (H+J)
- 11 Harbor Way (L1+L2)

Seaport Square Boston, Massachusetts

**SEAPORT**

**Exhibit D**

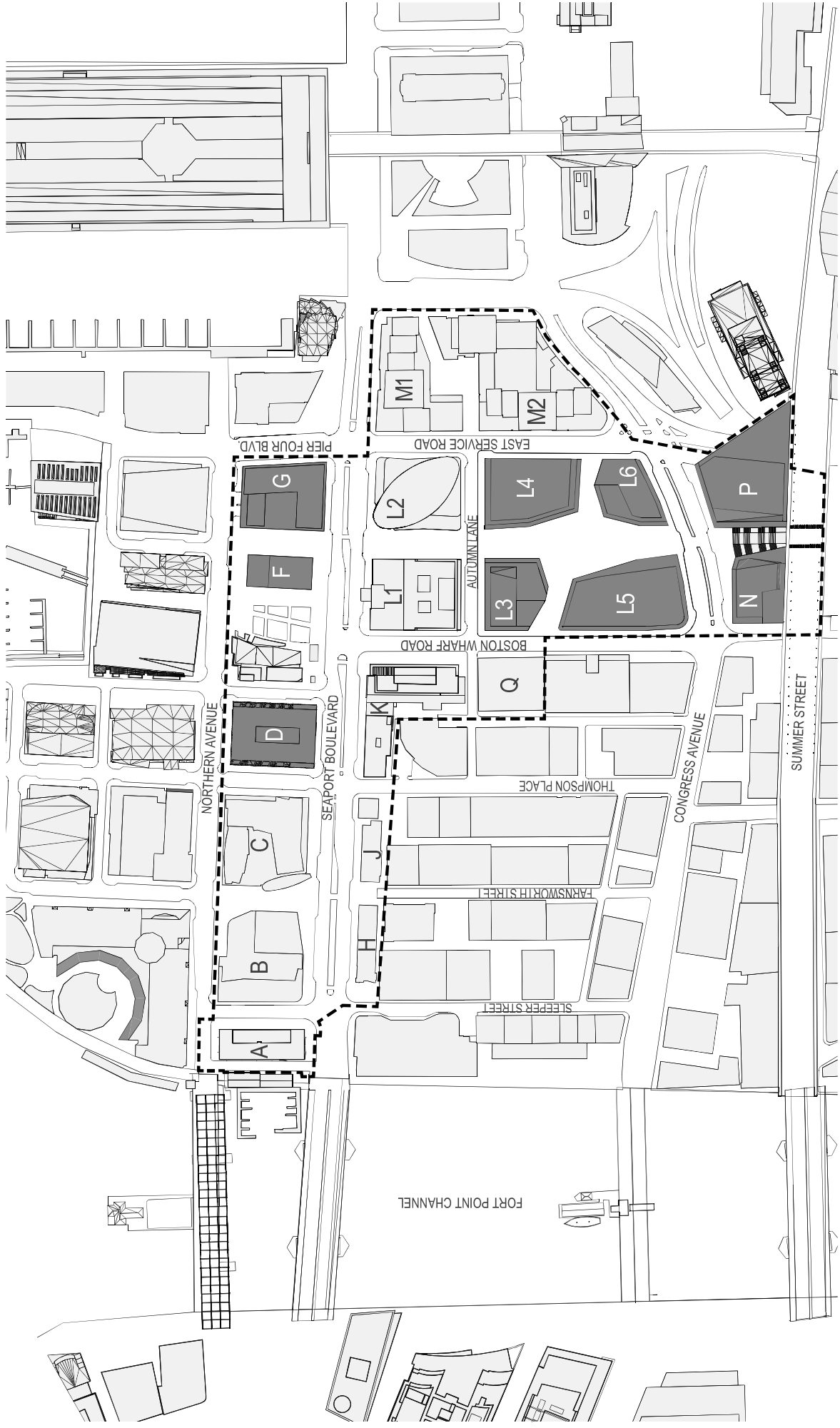
Block*	Maximum Build Out (sf of GFA)	Maximum Height (ft)	Maximum FAR
A	85,800	75	N/A
B	459,000	253	N/A
C	641,000	253	N/A
D	499,400	270	N/A
F	42,000**	55	N/A
G	671,800	260	N/A
H	24,000	90	N/A
J	99,000	107***	N/A
K	299,000	190	N/A
L1	455,300	250	N/A
L2	432,038	250	N/A
L3	417,000	270	N/A
L4	523,540	270	N/A
L5	707,000	270	N/A
L6	338,000	270	N/A
M1 & M2	1,012,000	260	N/A
N	422,000	270	N/A
P	591,000	270	N/A
Q	4,000	15	N/A
Total	7,723,110	N/A	7.55

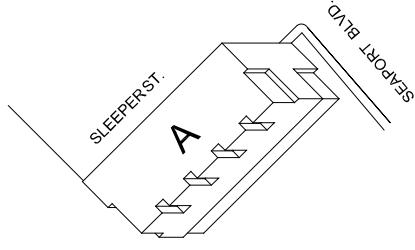
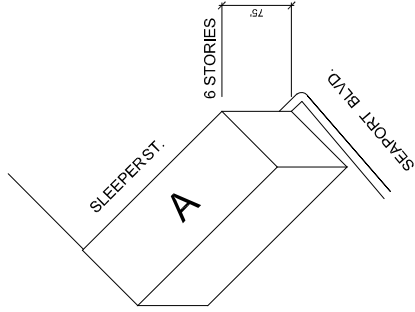
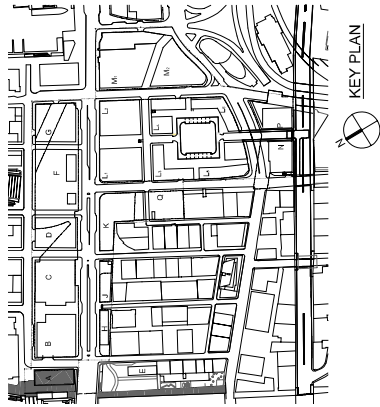
\* Other criteria to be satisfied by each block:

1. Size of the block and maximum footprint (as shown on Exhibit D: Block Plans & Parcelization)
2. Sidewalk dimensions (as shown on Exhibit H)
3. Provision of open space and other public realm elements (as shown on Exhibit C and described in Exhibit E)

\*\*This includes the existing Innovation Center building.

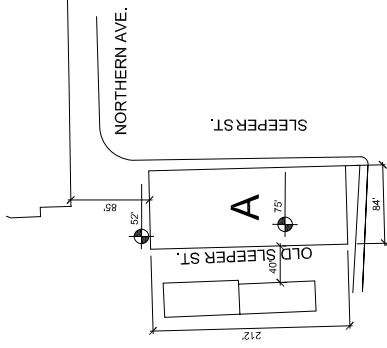
\*\*\*The Maximum Height shall apply to the penthouse floor; the height of the roof of the enclosed roof lounge-lobby area shall be approximately 122 feet.





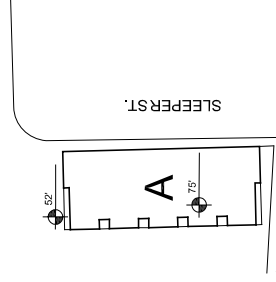
BLOCK "A"		
Proposed Max. GFA	Street Wall Heights	Max. Bldg Height
81,800 GSF	75'	75'

MASSING ENVELOPE AXON

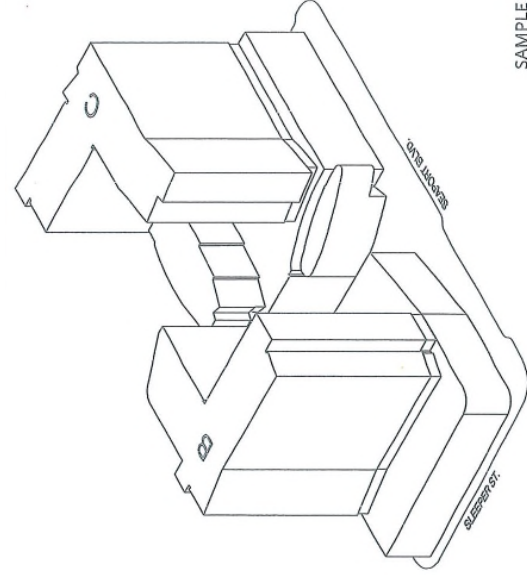


MASSING ENVELOPE ROOF PLAN

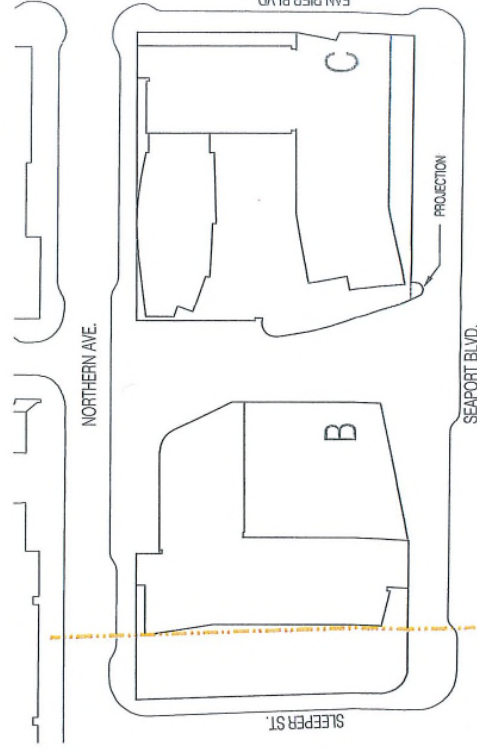
SAMPLE BUILDING MASSING



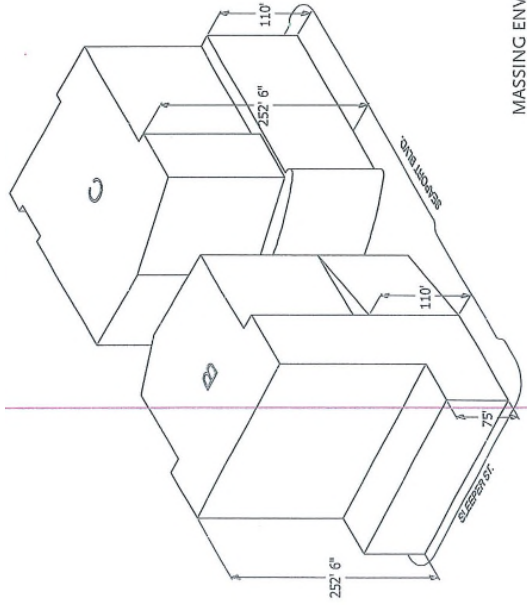
SAMPLE BUILDING MASSING ROOF PLAN



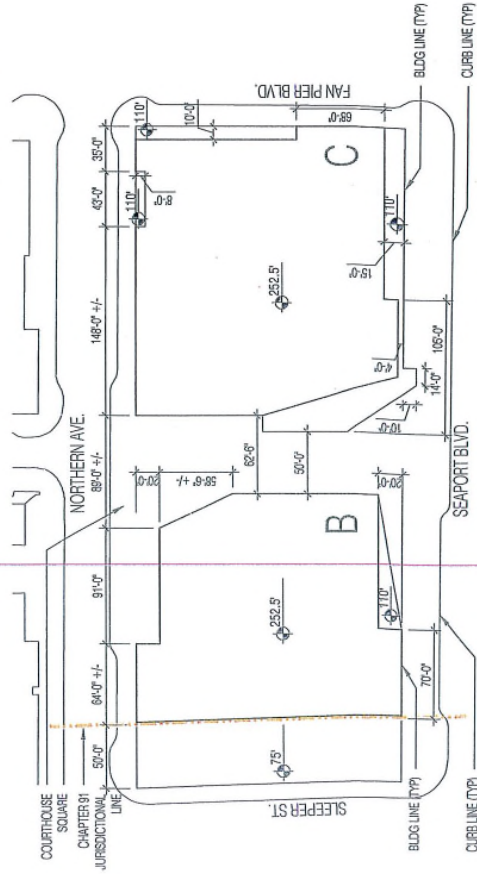
SAMPLE BUILDING MASSING



SAMPLE BUILDING MASSING ROOF PLAN



MASSING ENVELOPE AXON



MASSING ENVELOPE ROOF PLAN

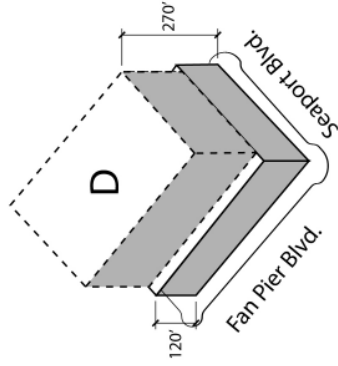




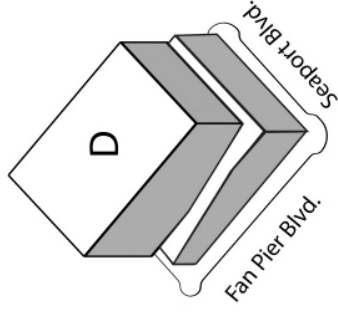
KEY PLAN

BLOCK "D"		
PROPOSED MAX. GFA	STREET WALL HEIGHTS	MAX. BUILDING HEIGHT
Block "D" : 499,400	120'	270'

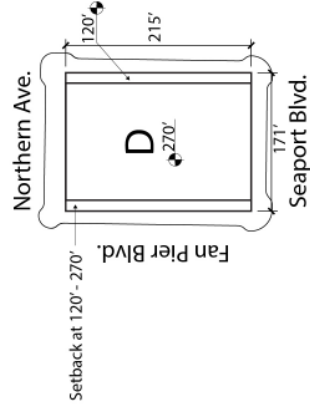
\* MAX. BUILDING HEIGHT IS MEASURED FROM GRADE



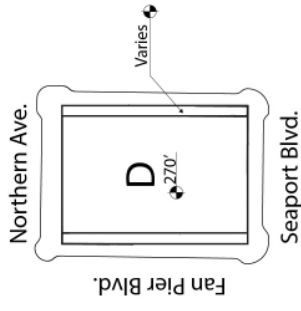
MASSING ENVELOPE AXON



SAMPLE BUILDING MASSING AXON



MASSING ENVELOPE PLAN



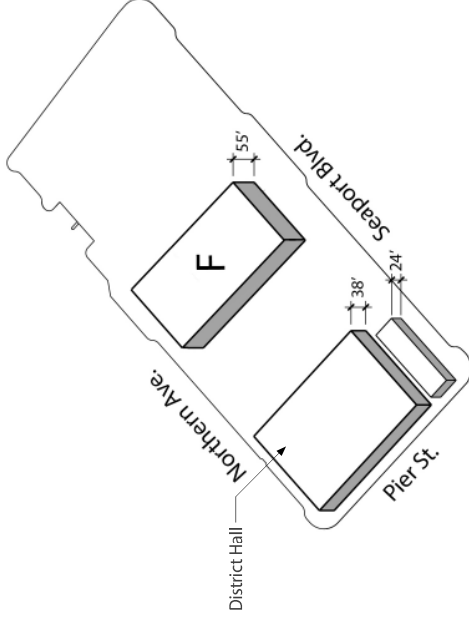
SAMPLE BUILDING MASSING PLAN



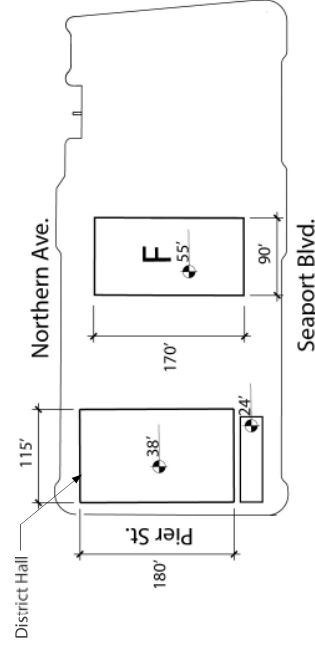
KEY PLAN

BLOCK "F"		
PROPOSED MAX. GFA	STREET WALL HEIGHTS	MAX. BUILDING HEIGHT
Block "F" : 42,000	40'-55'	55'

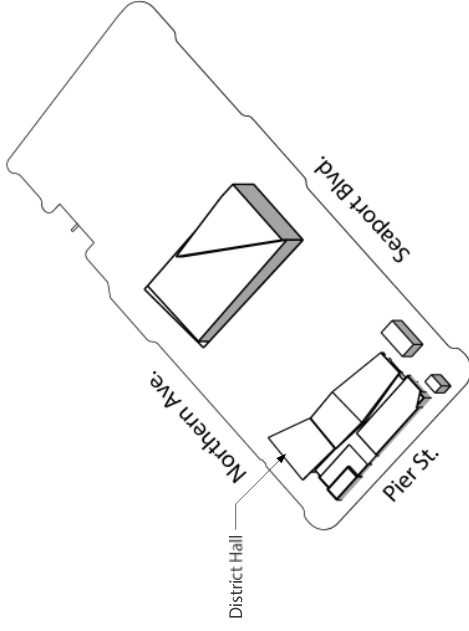
\* MAX. BUILDING HEIGHT IS MEASURED FROM GRADE



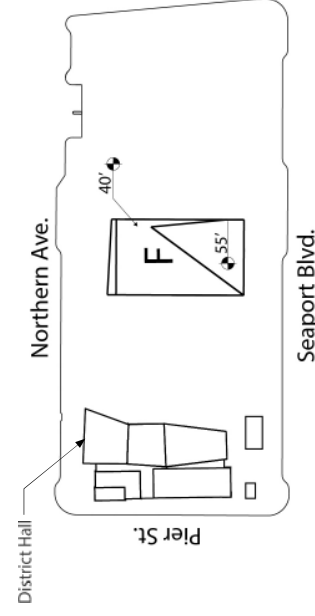
MASSING ENVELOPE AXON



MASSING ENVELOPE PLAN



SAMPLE BUILDING MASSING AXON



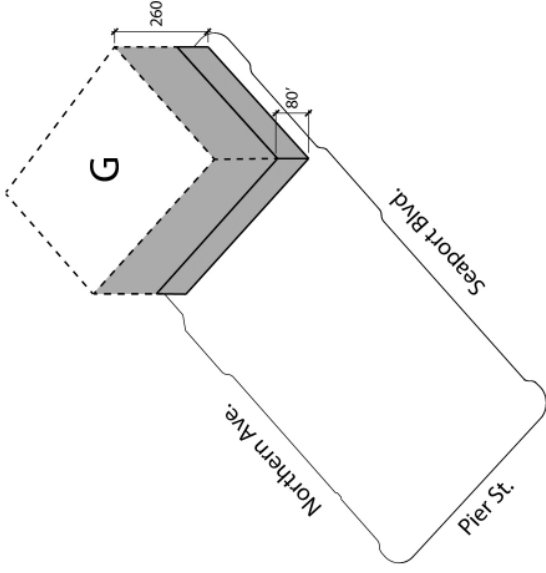
SAMPLE BUILDING MASSING PLAN



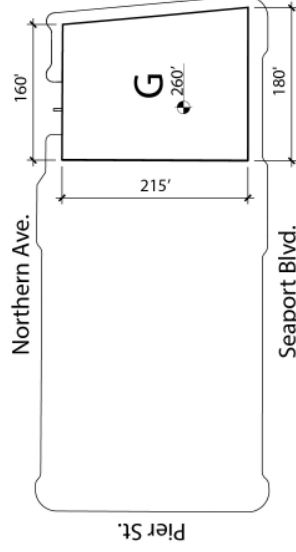
KEY PLAN

BLOCK "G"		
PROPOSED MAX. GFA	STREET WALL HEIGHTS	MAX. BUILDING HEIGHT
Block "G" : 671,800	80' - 260'	260'

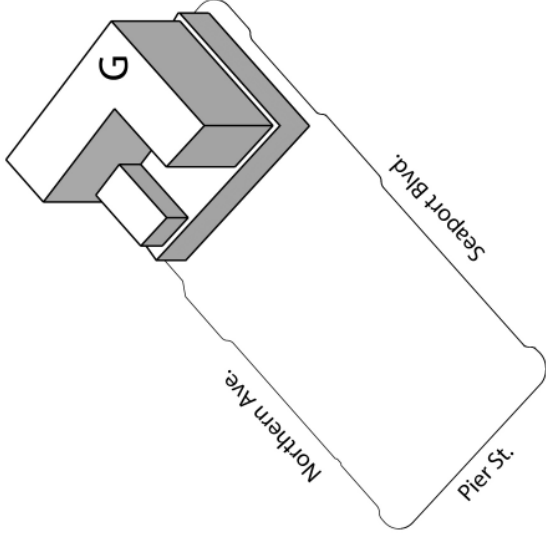
\* MAX. BUILDING HEIGHT IS MEASURED FROM GRADE



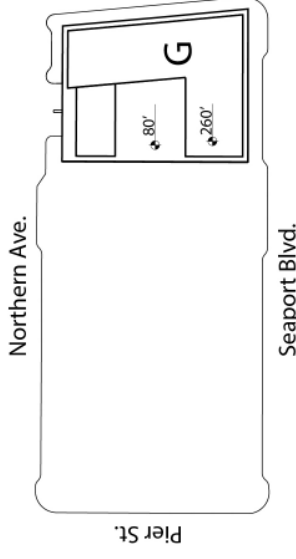
MASSING ENVELOPE AXON



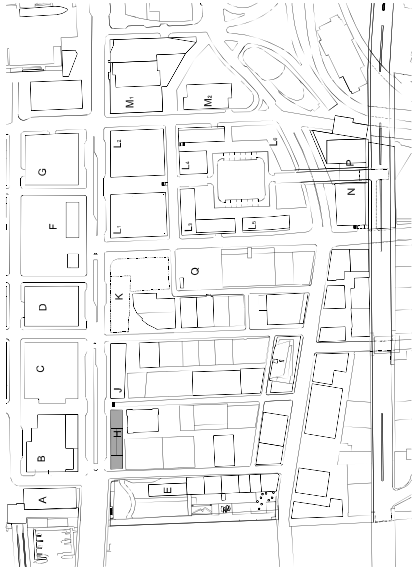
MASSING ENVELOPE PLAN



SAMPLE BUILDING MASSING AXON

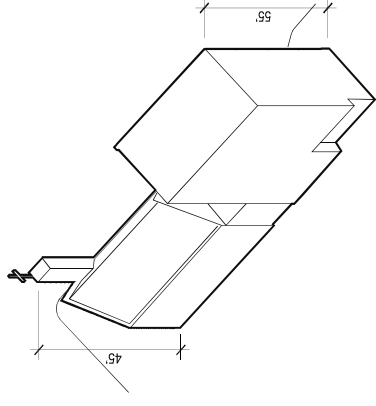


SAMPLE BUILDING MASSING PLAN

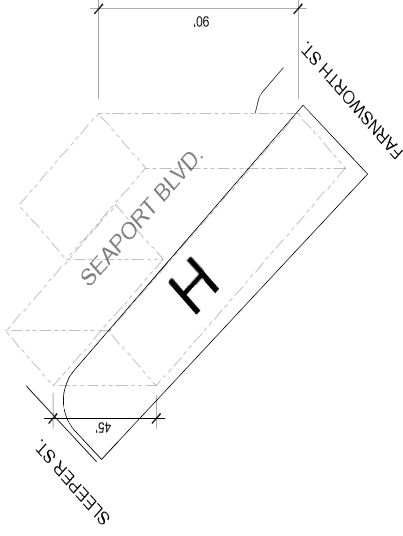


KEY PLAN

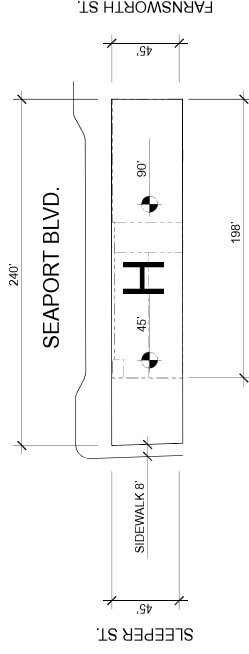
BLOCK "H"		
Proposed Max. GFA	Street Wall Heights	Max. Building Height
24,000	20'-55'	90'



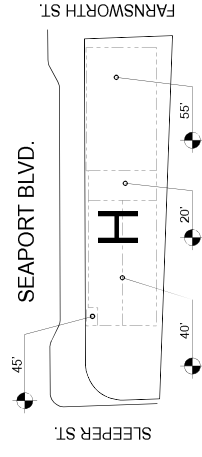
SAMPLE BUILDING MASSING



MASSING ENVELOPE AXON



MASSING ENVELOPE ROOF PLAN



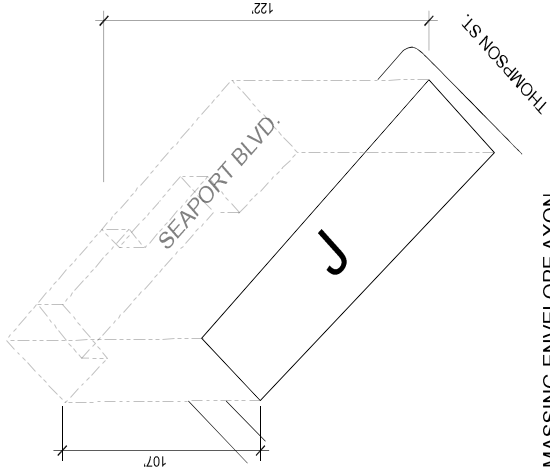
BUILDING MASSING ROOF PLAN



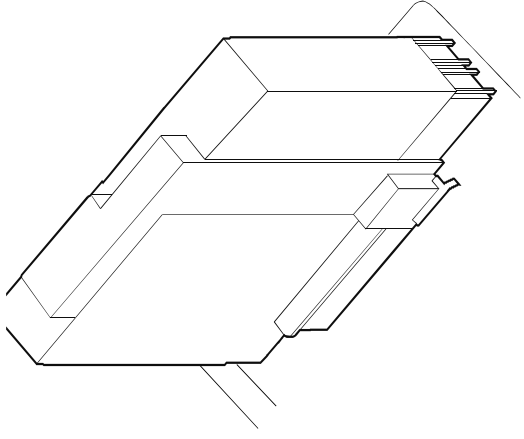
KEY PLAN

BLOCK "J"		
Proposed Max. GFA	Street Wall Heights	Max. Building Height*
99,000	107'	107'

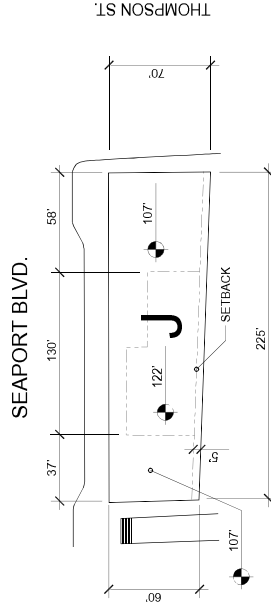
\* The Maximum Height shall apply to the penthouse floor; the height of the roof of the enclosed roof lounge/lobby area shall be approximately 122 feet



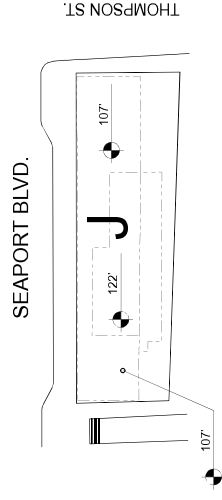
MASSING ENVELOPE AXON



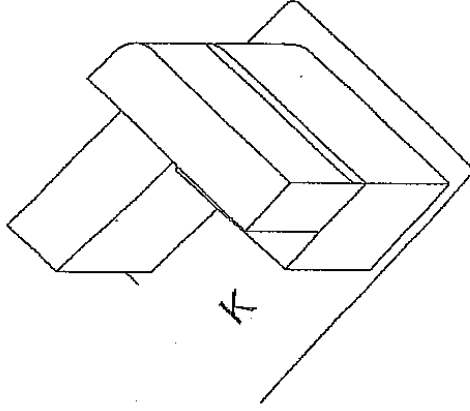
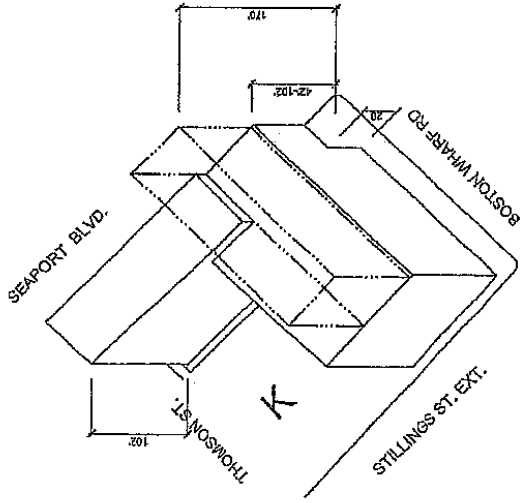
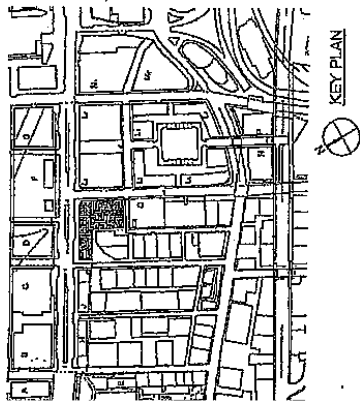
SAMPLE BUILDING MASSING



MASSING ENVELOPE ROOF PLAN



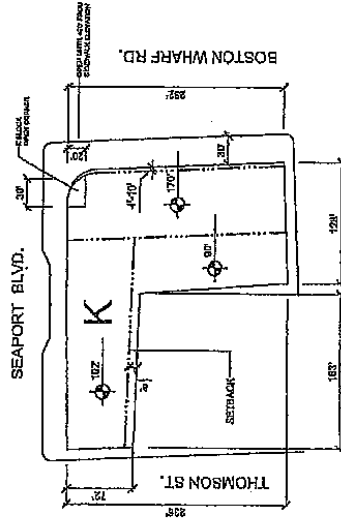
BUILDING MASSING ROOF PLAN



MASSING ENVELOPE AXON

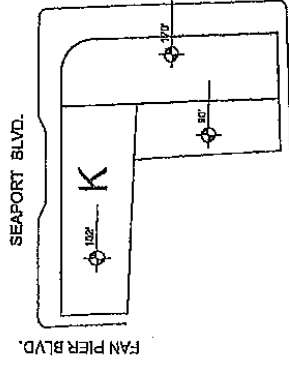
SAMPLE BUILDING MASSING

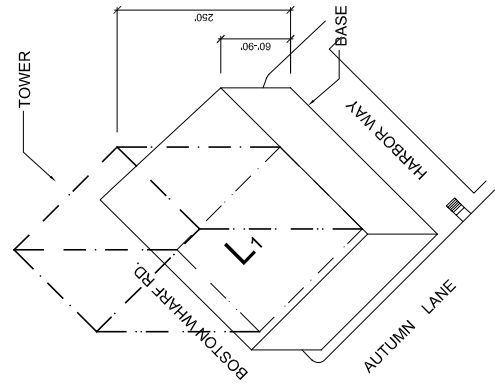
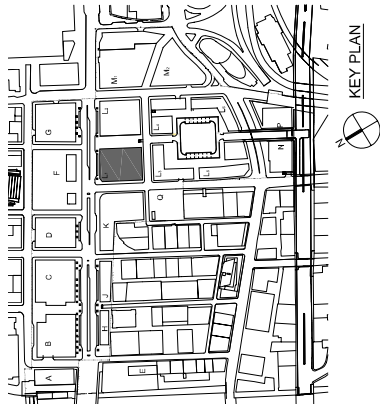
BLOCK K		
Proposed Max. GFA	293,000	
Street Wall Heights	42'-102'	
Max. Bldg Height		190'



MASSING ENVELOPE ROOF PLAN

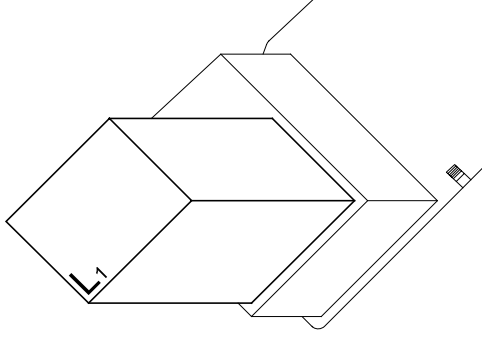
SAMPLE BUILDING MASSING ROOF PLAN



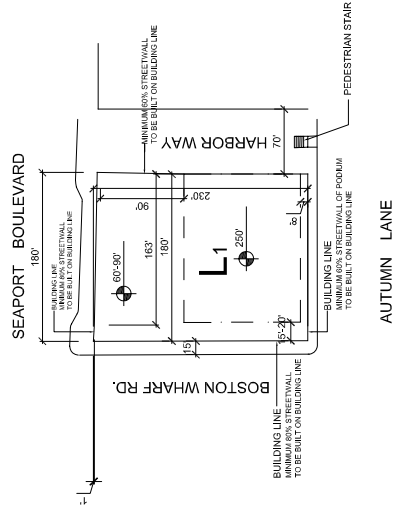


MASSING ENVELOPE AXON

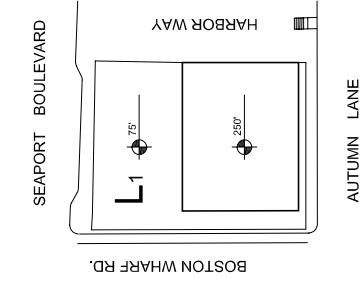
BLOCK 'L1'			
Proposed Max. GFA	Street Wall Heights	Max. Bldg Height	250'
455,300 GSF	60'-90'		



SAMPLE BUILDING MASSING



MASSING ENVELOPE ROOF PLAN

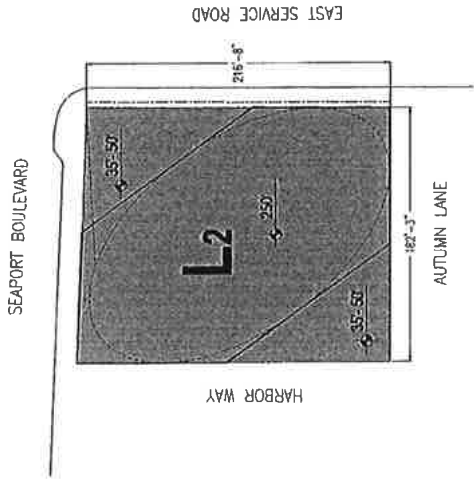


SAMPLE BUILDING MASSING ROOF PLAN

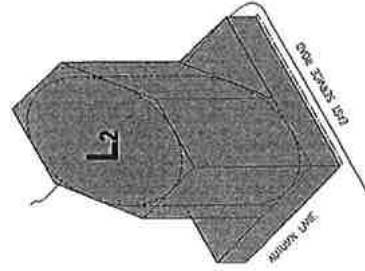


BLOCK 'L2'		
PROPOSED BLDG. CFA	PROPOSED BLDG. WALL	MAXIMUM BUILDING HEIGHT
0.45M <sup>2</sup> /M	3.0M	20'

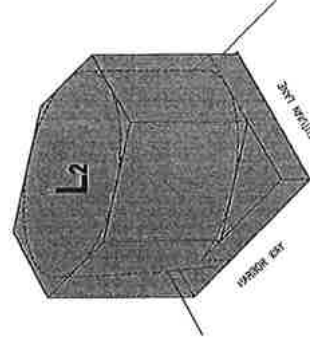
NOTE: SAMPLE BUILDING MASSING SHOWN IN DOTTED LINES TO ACCOMMODATE BLDG. REPRESENTATIVE DURING THE DESIGN DESIGN AND PUBLIC AGENCY REVIEW PHASES.



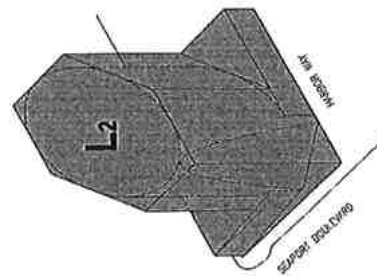
1. PROPOSED BLDG. MASSING - FRONT VIEW



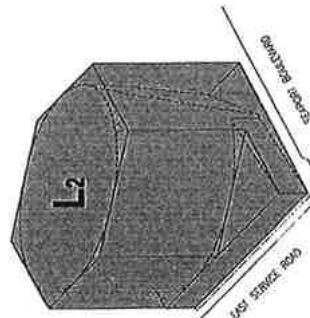
5. PROPOSED BLDG. MASSING - SIDE VIEW TO CORNER



4. PROPOSED BLDG. MASSING - SIDE VIEW TO CORNER



3. PROPOSED BLDG. MASSING - SIDE VIEW TO CORNER



2. PROPOSED BLDG. MASSING - SIDE VIEW TO CORNER

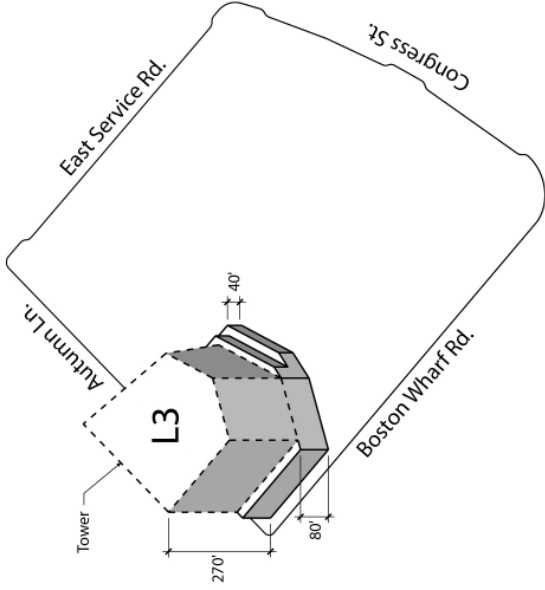




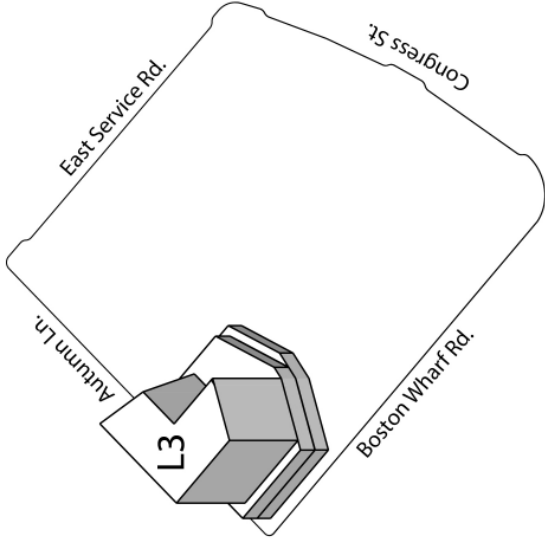
KEY PLAN

BLOCK "L3"		
PROPOSED MAX. GFA	STREET WALL HEIGHTS	MAX. BUILDING HEIGHT
Block "L3" : 417,000	40' - 270'	270'

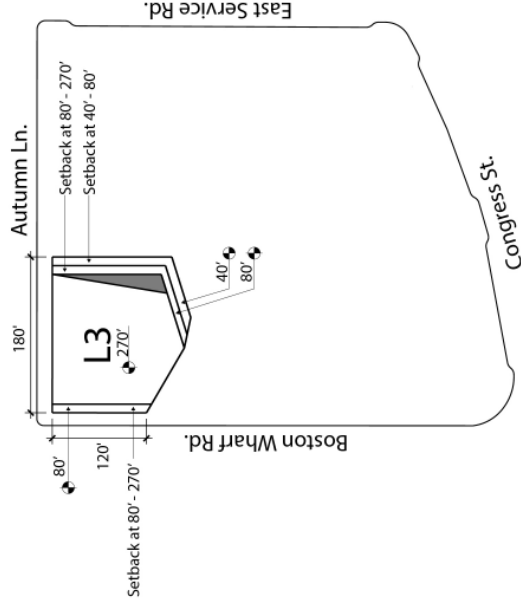
\* MAX. BUILDING HEIGHT IS MEASURED FROM GRADE



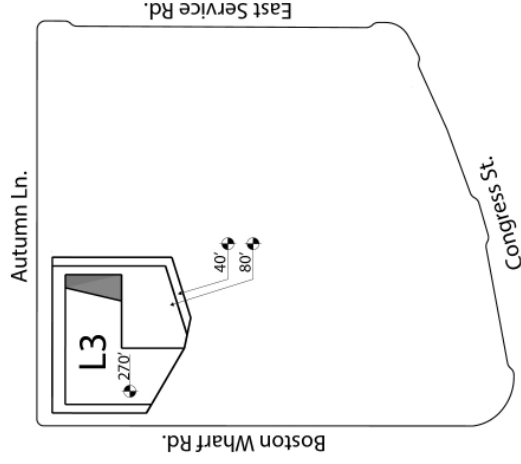
MASSING ENVELOPE AXON



SAMPLE BUILDING MASSING AXON



MASSING ENVELOPE PLAN



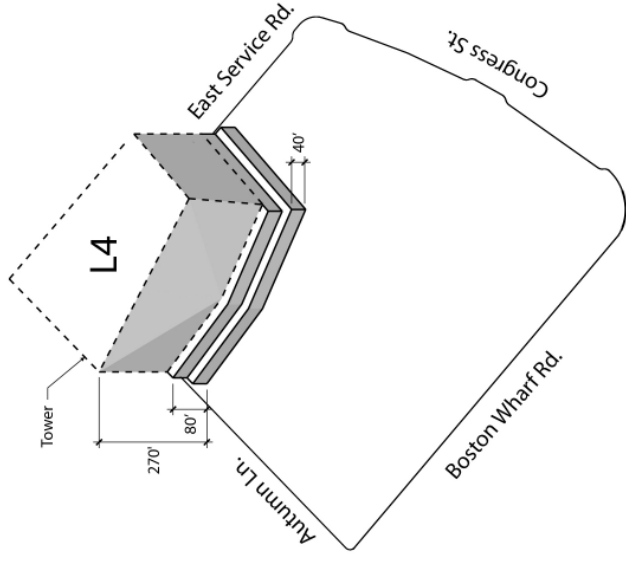
SAMPLE BUILDING MASSING PLAN



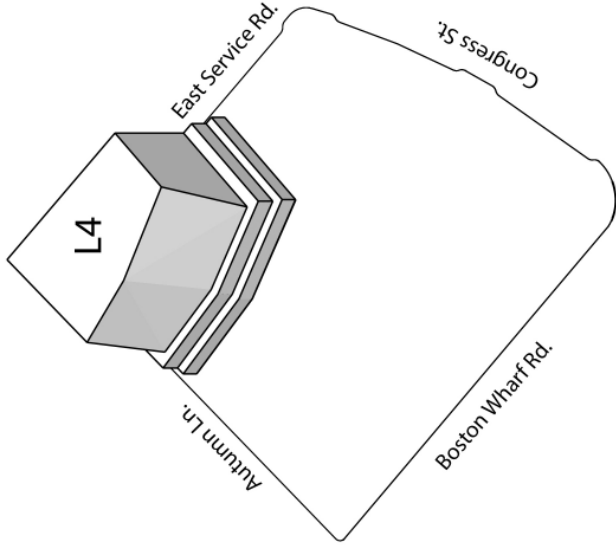
KEY PLAN

BLOCK "L4"		
PROPOSED MAX. GFA	STREET WALL HEIGHTS	MAX. BUILDING HEIGHT
Block "L4" : 523,540	40' - 270'	270'

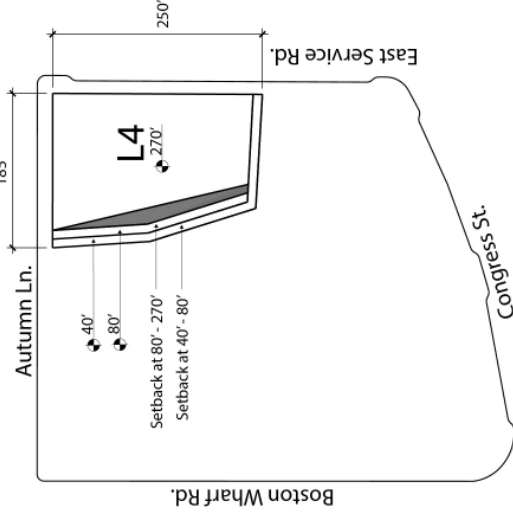
\* MAX. BUILDING HEIGHT IS MEASURED FROM GRADE



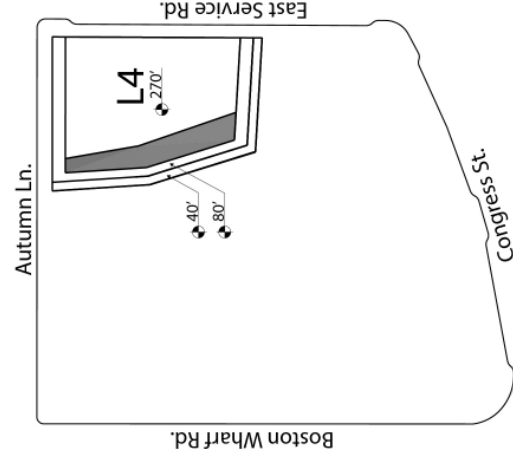
MASSING ENVELOPE AXON



SAMPLE BUILDING MASSING AXON



MASSING ENVELOPE PLAN



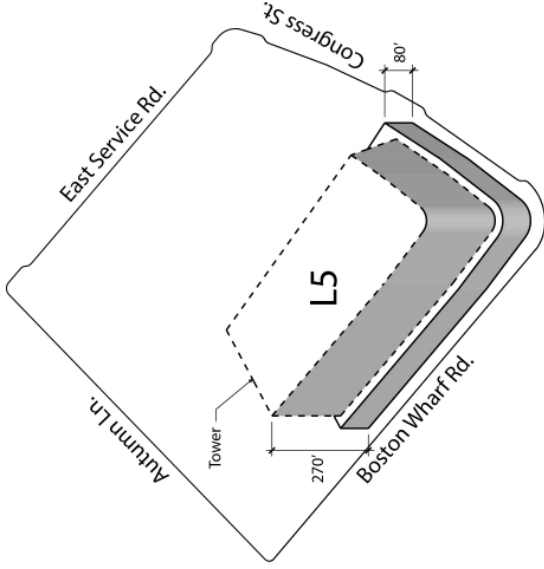
SAMPLE BUILDING MASSING PLAN



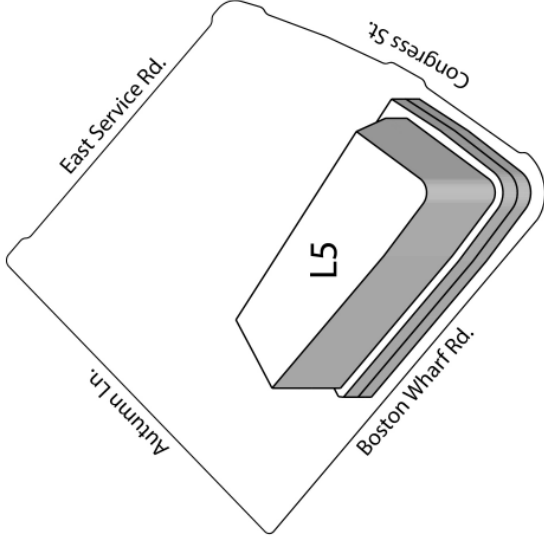
KEY PLAN

BLOCK "L5"		
PROPOSED MAX. GFA	STREET WALL HEIGHTS	MAX. BUILDING HEIGHT
Block "L5" : 707,000	80'	270'

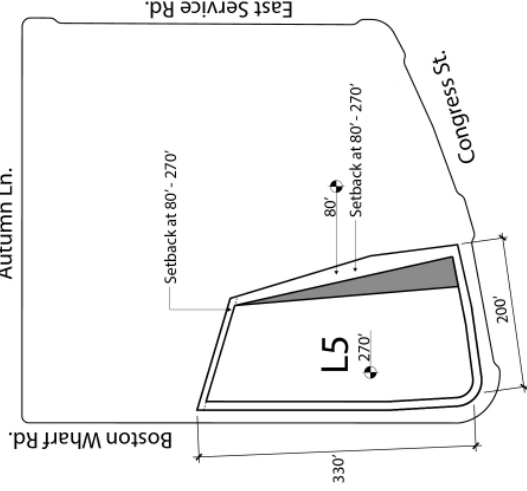
\* MAX. BUILDING HEIGHT IS MEASURED FROM GRADE



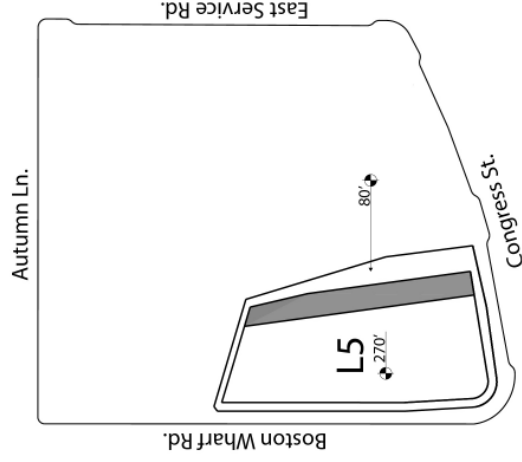
MASSING ENVELOPE AXON



SAMPLE BUILDING MASSING AXON



MASSING ENVELOPE PLAN



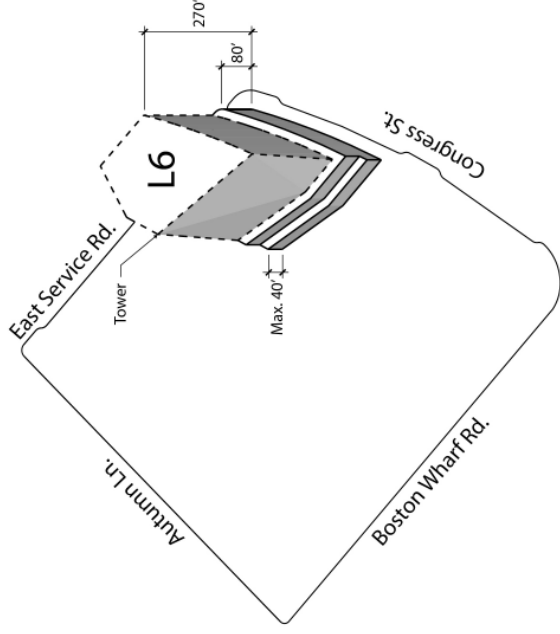
SAMPLE BUILDING MASSING PLAN



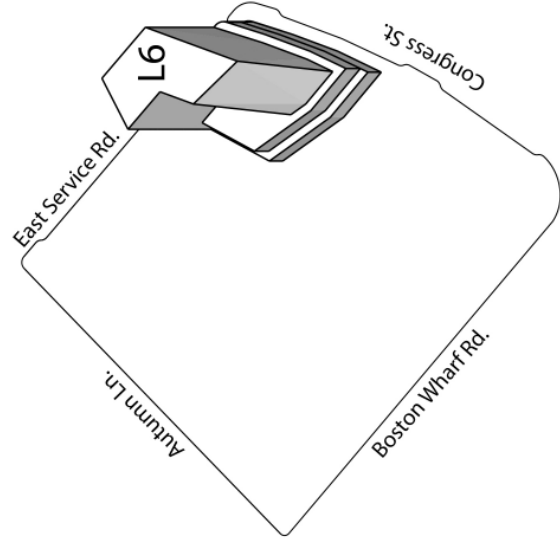
KEY PLAN

BLOCK "L6"		
PROPOSED MAX. GFA	STREET WALL HEIGHTS	MAX. BUILDING HEIGHT
Block "L6" : 338,000	40'- 270'	270'

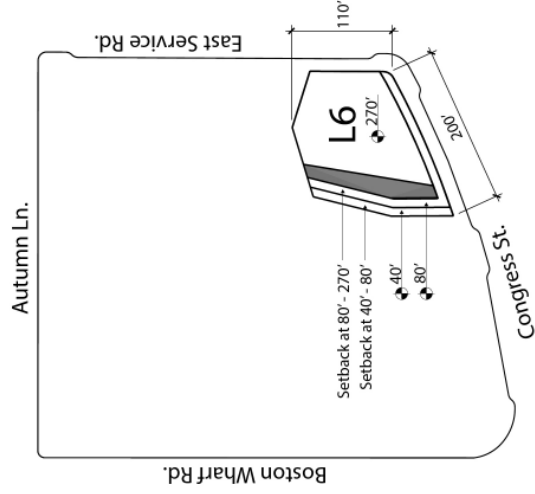
\* MAX. BUILDING HEIGHT IS MEASURED FROM GRADE



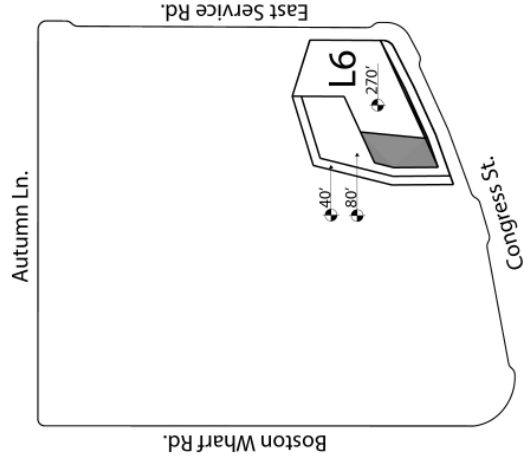
MASSING ENVELOPE AXON



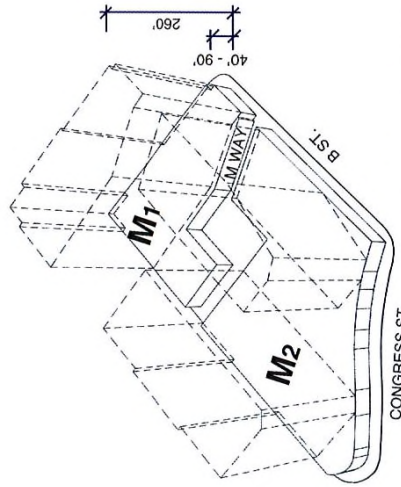
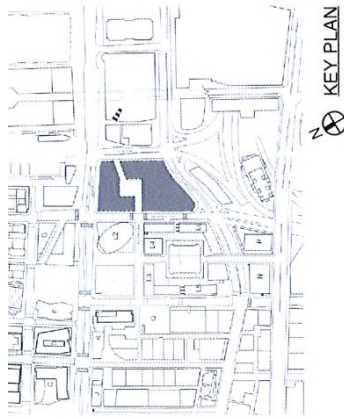
SAMPLE BUILDING MASSING AXON



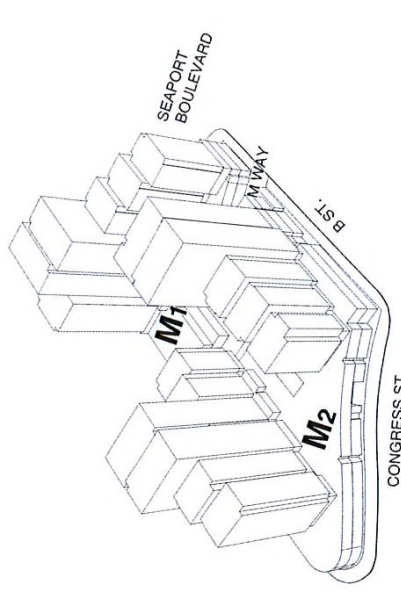
MASSING ENVELOPE PLAN



SAMPLE BUILDING MASSING PLAN

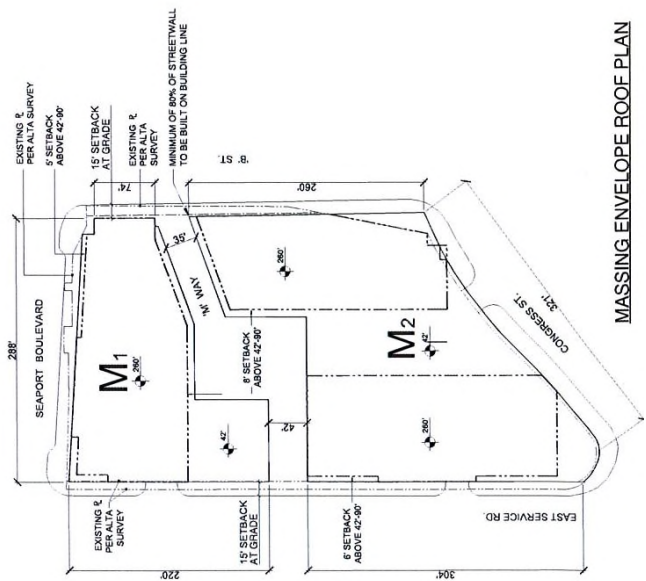


MASSING ENVELOPE AXON

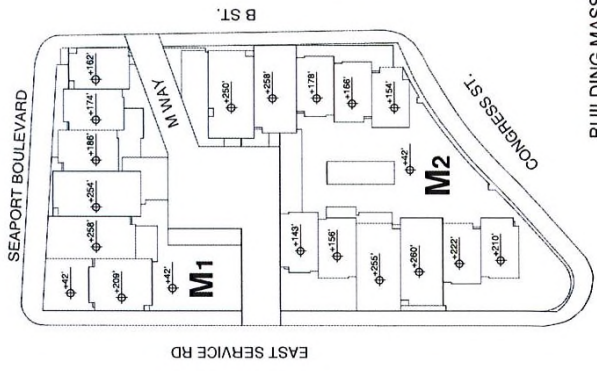


BUILDING MASSING

BLOCK M1 and M2		
Proposed Max. GFA	Street Wall Heights	Max. Bldg Height
1,012,000 GFA	40'-90'	260'



MASSING ENVELOPE ROOF PLAN



BUILDING MASSING ROOF PLAN

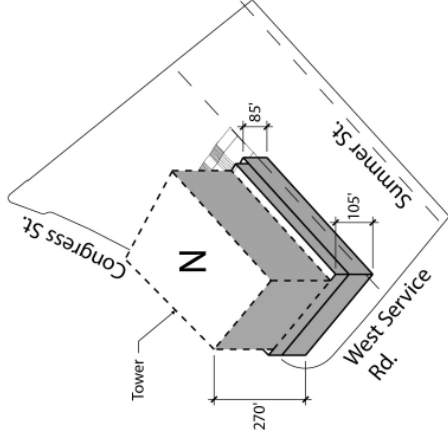


KEY PLAN

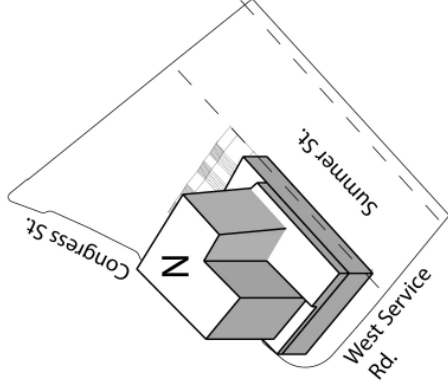
BLOCK "N"		
PROPOSED MAX. GFA	STREET WALL HEIGHTS	MAX. BUILDING HEIGHT
Block "N" : 422,000	85'-270'	270'

\* SUMMER STREET IS AN EXISTING STREET ELEVATED 26' FROM GROUND LEVEL

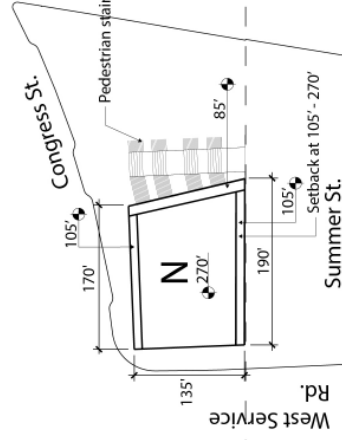
\*\* ELEVATIONS SHOWN ARE RELATIVE TO GROUND LEVEL AT CONGRESS STREET



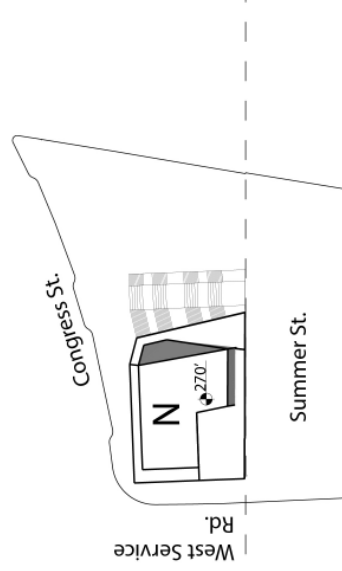
MASSING ENVELOPE AXON



SAMPLE BUILDING MASSING AXON



MASSING ENVELOPE PLAN



SAMPLE BUILDING MASSING PLAN

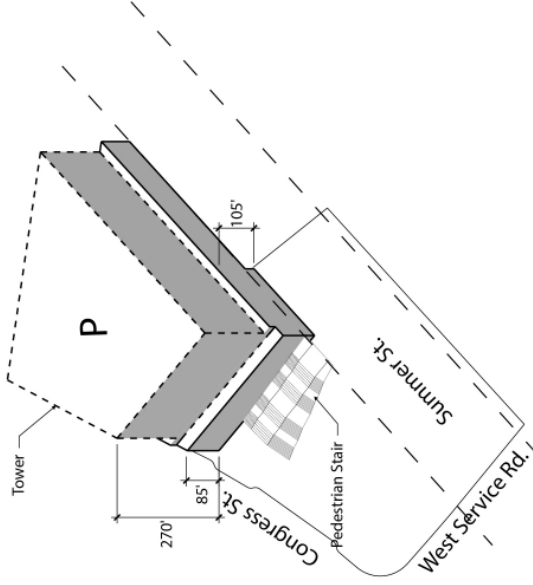


KEY PLAN

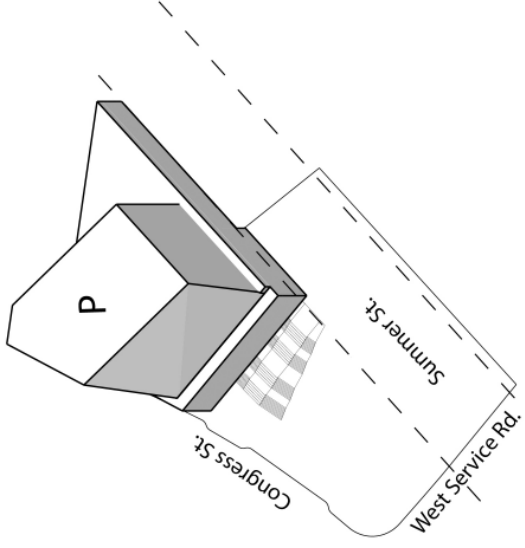
BLOCK "P"		
PROPOSED MAX. GFA	STREET WALL HEIGHTS	MAX. BUILDING HEIGHT
Block "P" : 591,000	85'-105'	270'

\* SUMMER STREET IS AN EXISTING STREET ELEVATED 26' FROM GROUND LEVEL

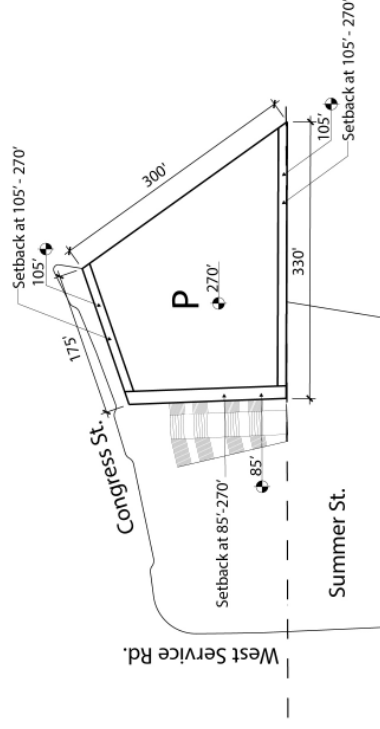
\*\* ELEVATIONS SHOWN ARE RELATIVE TO GROUND LEVEL AT CONGRESS STREET



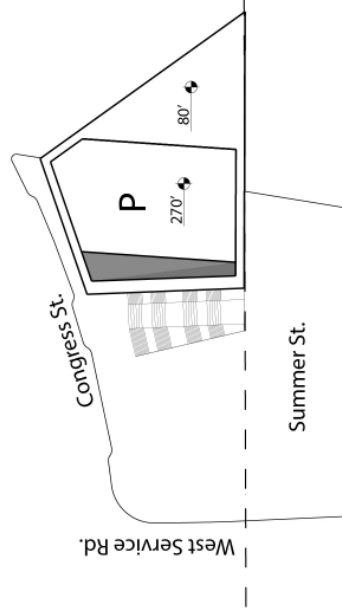
MASSING ENVELOPE AXON



SAMPLE BUILDING MASSING AXON



MASSING ENVELOPE PLAN



SAMPLE BUILDING MASSING PLAN

**EXHIBIT E**

**APPROVED USES, PUBLIC REALM IMPROVEMENTS AND BENEFITS**

<b><u>Block</u></b>	<b><u>Approved Uses<sup>1</sup></u></b>	<b><u>Public Realm Improvements and Benefits</u></b>	
<b><u>EARLY ACTION BENEFITS</u></b>			<b><u>Timing<sup>2</sup></u></b>
BLOCK Q	<ul style="list-style-type: none"> <li>▪ Open Space Uses</li> <li>▪ Park Pavilion: (including Local Retail/Services Uses; Restaurant Uses)</li> <li>▪ Off-premises advertising (on wall of 22 Boston Wharf Road building)</li> </ul>	<ul style="list-style-type: none"> <li>▪ Sidewalk improvements (Stillings Extension and Boston Wharf Road)</li> <li>▪ Active recreational space</li> </ul>	<ul style="list-style-type: none"> <li>▪ Complete (although Park Pavilion may be added).</li> </ul>
BLOCK F	<ul style="list-style-type: none"> <li>▪ Innovation Uses</li> </ul>	<ul style="list-style-type: none"> <li>▪ Innovation Center</li> </ul>	<ul style="list-style-type: none"> <li>▪ Complete.</li> </ul>
Parcel E	N/A	<ul style="list-style-type: none"> <li>▪ Contribute to Improvements</li> </ul>	<ul style="list-style-type: none"> <li>▪ Complete.</li> </ul>
Interim ICA Connector	N/A		<ul style="list-style-type: none"> <li>▪ Complete</li> </ul>

<sup>1</sup> For the purposes of this Exhibit E, the Approved Uses listed below may include Accessory and Ancillary Uses listed on Exhibit F. This Exhibit E governs the Allowed Uses for each specific Block. Any changes to the uses for any Block shall be subject to an amendment to this Plan.

<sup>2</sup> All timing is subject to the cooperation of the BPDA and other state and City agencies with respect to final approvals and the issuance of permits where required.



**DEVELOPMENT BLOCKS**

<b><u>Block</u></b>	<b><u>Approved Uses<sup>3</sup></u></b>	<b><u>Public Realm Improvements and Benefits</u></b>
BLOCK A	<ul style="list-style-type: none"> <li>▪ Retail/Entertainment/ Restaurant/ Services Uses</li> <li>▪ Residential Uses</li> <li>▪ Office Uses</li> <li>▪ Hotel Uses</li> <li>▪ Civic/Community and Cultural Uses</li> <li>▪ Restaurant Uses</li> <li>▪ Accessory parking</li> </ul>	<ul style="list-style-type: none"> <li>▪ Construction of Old Sleeper Street Pedestrian Way (connecting existing segments of the Harborwalk)</li> <li>▪ Approximately 2,000 sf of Gross Floor Area for Seaport District visitors' center or similar civic space</li> <li>▪ Construction of Northern Avenue to connect to Old Northern Avenue Bridge</li> <li>▪ Sidewalk improvements (adjacent portions of Sleeper Street, Seaport Boulevard)</li> </ul>
BLOCK H	<ul style="list-style-type: none"> <li>▪ Place of Worship</li> <li>▪ Retail/Entertainment/ Restaurant/Service Uses</li> <li>▪ Innovation Uses</li> <li>▪ Education/Cultural Uses</li> <li>▪ Office Uses</li> <li>▪ Open Space Uses</li> <li>▪ Civic/Community Uses</li> </ul>	<ul style="list-style-type: none"> <li>▪ New Chapel</li> <li>▪ Open space at Sleeper Street end of Block</li> <li>▪ Sidewalk on adjacent portions of Seaport Boulevard</li> </ul>
BLOCK J	<ul style="list-style-type: none"> <li>▪ Innovation Uses</li> <li>▪ Hotel Uses</li> </ul>	<ul style="list-style-type: none"> <li>▪ MBTA Silver Line head house improvements incorporated into development</li> <li>▪ Farnsworth Pedestrian Link and</li> </ul>

<sup>3</sup> For the purposes of this Exhibit E, the Approved Uses listed below may include Accessory and Ancillary Uses listed on Exhibit E. This Exhibit E governs the Allowed Uses for each specific Block. Any changes to the uses for any Block shall be subject to an amendment to this Plan.

	<ul style="list-style-type: none"> <li>▪ Residential Uses</li> <li>▪ Retail/Entertainment/ Restaurant/Services Uses</li> <li>▪ Office Uses</li> <li>▪ Transportation Uses</li> <li>▪ Civic/Community and Cultural Uses</li> </ul>	<p>connection to Seaport Boulevard (see Section XV.c.ii)</p> <ul style="list-style-type: none"> <li>▪ Thomson Seaport Extension</li> <li>▪ Sidewalk Improvements (adjacent portions of Seaport Boulevard, Farnsworth Street and Thomson Place)</li> </ul>
BLOCK B	<ul style="list-style-type: none"> <li>▪ Retail/Entertainment/ Restaurant/ Services Uses</li> <li>▪ Residential Uses</li> <li>▪ Public and Accessory parking</li> <li>▪ Innovation Uses</li> <li>▪ Civic/Community and Cultural Uses</li> </ul>	<ul style="list-style-type: none"> <li>▪ Courthouse Square (portion within Block B constructed with Block B; remainder constructed upon completion of the later of Block B or Block C; 10-foot wide pedestrian passage if B completed before C)</li> <li>▪ Seaport Boulevard Improvements (area adjacent to Block and corresponding median)</li> <li>▪ Sidewalk Improvements (Northern Avenue, Seaport Boulevard, and Sleeper Street)</li> <li>▪ Northern Avenue Improvements (area adjacent to Block)</li> <li>▪ Public parking</li> <li>▪ Car-sharing (on Block B and/or Block C)</li> </ul>

BLOCK C	<ul style="list-style-type: none"> <li>▪ Retail/Entertainment/ Restaurant/ Services Uses</li> <li>▪ Public Infrastructure Uses</li> <li>▪ Residential Uses</li> <li>▪ Public and Accessory parking</li> <li>▪ Innovation Uses</li> <li>▪ Civic/Community and Cultural Uses</li> </ul>	<ul style="list-style-type: none"> <li>▪ Courthouse Square (upon completion of later of Block B or Block C; 10-foot wide pedestrian passage if C completed before B)</li> <li>▪ Fan Pier Boulevard Extension (upon completion of Block C or Block D, whichever is earlier)</li> <li>▪ Seaport Boulevard Improvements (area adjacent to Block and corresponding median)</li> <li>▪ Sidewalk Improvements (adjacent portions of Northern Avenue, Fan Pier Boulevard)</li> <li>▪ Northern Avenue Improvements (area adjacent to Block)</li> <li>▪ Public parking</li> <li>▪ Car-sharing (on Block B and/or Block C)</li> </ul>
BLOCK D	<ul style="list-style-type: none"> <li>▪ Innovation Uses</li> <li>▪ Retail/Entertainment/ Restaurant/ Services Uses, open to the public</li> <li>▪ Civic/Community and Cultural Uses</li> <li>▪ Educational Uses</li> <li>▪ Office Uses</li> <li>▪ Public and Accessory parking</li> </ul>	<ul style="list-style-type: none"> <li>▪ Seaport Boulevard Improvements (including median corresponding to Block)</li> <li>▪ Sidewalk Improvements (adjacent portions of Northern Avenue, Seaport Boulevard, Fan Pier Boulevard)</li> <li>▪ Northern Avenue Improvements (area adjacent to Block)</li> <li>▪ Pier Street (between Block D and Block F)</li> <li>▪ 5,000 sf of civic/educational use</li> <li>▪ MBTA Silver Line head house on Block F</li> <li>▪ Advance the design of the planned Summer Street/Massport Haul Road/Drydock Avenue/Pappas Way Connector connection to 25% with BTB (upon completion of the earlier of Block D or Block G)</li> </ul>

<p>BLOCK F</p>	<ul style="list-style-type: none"> <li>▪ Innovation Uses</li> <li>▪ Open Space Uses, including memorials, water features</li> <li>▪ Park Pavilion: (including Local Retail/Services Uses; Restaurant Uses)</li> <li>▪ Local Retail/Services Uses; Restaurant Uses</li> <li>▪ Office Uses</li> <li>▪ Public and Accessory parking</li> <li>▪ Civic/Community and Cultural Uses</li> <li>▪ Educational Uses</li> <li>▪ Transportation Uses</li> </ul>	<ul style="list-style-type: none"> <li>▪ Innovation Center (term as set forth in Section __ above)</li> <li>▪ Seaport Common (completed; expansion to approximately 40,000 sf to be completed with Block F retail pavilion building)</li> <li>▪ Seaport Boulevard Improvements (including median corresponding to Block)</li> <li>▪ Other sidewalk improvements, including wide sidewalks with pedestrian amenities adjacent to Common</li> <li>▪ Northern Avenue Improvements (area adjacent to Block)</li> <li>▪ Pedestrian-only Harbor Way segment between Seaport Boulevard and Northern Avenue (upon completion of the earlier of Block F or Block G)</li> <li>▪ New MBTA Silver Line head house (with Block D)</li> <li>▪ 1,500 GSF Civic Space</li> </ul>
----------------	---	--

<p>BLOCK G</p>	<ul style="list-style-type: none"> <li>▪ Innovation Uses</li> <li>▪ Retail/Entertainment/Restaurant/ Services Uses</li> <li>▪ Civic/Community and Cultural Uses</li> <li>▪ Educational Uses</li> <li>▪ Residential Uses</li> <li>▪ Office Uses</li> <li>▪ Hotel Uses</li> <li>▪ Public and Accessory parking</li> </ul>	<ul style="list-style-type: none"> <li>▪ Approximately 5,000 square feet of flexible Exhibition Space</li> <li>▪ Pedestrian-only Harbor Way segment between Seaport Boulevard and Northern Avenue (upon completion of the earlier of Block F or Block G)</li> <li>▪ Seaport Boulevard Improvements (including median corresponding to Block)</li> <li>▪ Sidewalk Improvements (adjacent portions of Northern Avenue, and Pier Four Boulevard)</li> <li>▪ Northern Avenue Improvements (area adjacent to Block)</li> <li>▪ Advance the design of the planned Summer Street/Massport Haul Road/Drydock Avenue/Pappas Way Connector connection to 25% with BTB (upon completion of the earlier of Block D or Block G)</li> </ul>
<p>BLOCK K</p>	<ul style="list-style-type: none"> <li>▪ Innovation Uses</li> <li>▪ Retail/Entertainment/Restaurant/ Services Uses</li> <li>▪ Residential Uses</li> <li>▪ Hotel Uses</li> <li>▪ Public and Accessory parking</li> <li>▪ Civic/Community and Cultural Uses</li> </ul>	<ul style="list-style-type: none"> <li>▪ Stillings Extension (upon completion of earlier of Block K or Block Q)</li> <li>▪ Sidewalk improvements (adjacent portions of Seaport Boulevard, Thomson Street, Boston Wharf Road and Stillings Extension)</li> <li>▪ Block K Open Corner</li> <li>▪ Public parking</li> </ul>

<p>BLOCKS L1-L2</p>	<ul style="list-style-type: none"> <li>▪ Innovation Uses</li> <li>▪ Retail/Entertainment/ Restaurant/ Services Uses</li> <li>▪ Office Uses</li> <li>▪ Public and Accessory parking</li> <li>▪ Civic/Community and Cultural Uses</li> </ul>	<ul style="list-style-type: none"> <li>▪ Autumn Lane (upon completion of earlier of Blocks L1-L2 or Blocks L3-L6)</li> <li>▪ Harbor Way (upon completion of the later of Blocks L1 or L2; a 20-foot pedestrian passage will be constructed with the earlier of L1 or L2)</li> <li>▪ Sidewalk Improvements (adjacent portions of Seaport Boulevard, Autumn Lane, Pier Four Boulevard and Boston Wharf Road)</li> <li>▪ Public parking</li> </ul>
<p>BLOCKS L3-L6</p>	<ul style="list-style-type: none"> <li>▪ Retail/Entertainment/ Restaurant/ Services Uses</li> <li>▪ Innovation Uses</li> <li>▪ Residential Uses</li> <li>▪ Office Uses</li> <li>▪ Hotel Uses</li> <li>▪ Civic/Community and Cultural Uses</li> <li>▪ Public and Accessory parking</li> </ul>	<ul style="list-style-type: none"> <li>▪ Harbor Way and Harbor Square park (upon completion of the earliest of Blocks L3 and L5 or L4 and L6)</li> <li>▪ Sidewalk Improvements (adjacent portions of Congress Street, Autumn Lane, East Service Road, Boston Wharf Road)</li> <li>▪ Public art and/or landscaping installations</li> <li>▪ Mid-Block Pedestrian Crossing to the Summer Street Steps</li> <li>▪ Bicycle improvements on Boston Wharf Road from Congress Street to Seaport Boulevard (with the later Blocks L3 and L5)</li> <li>▪ Fort Point Community Theater (unless this is included with the SeaPAC on Block P)</li> <li>▪ Incubator Retail Pop-up Space</li> </ul>

BLOCK M1	<ul style="list-style-type: none"> <li>▪ Innovation Uses</li> <li>▪ Retail/Entertainment/ Restaurant/ Services Uses</li> <li>▪ Residential Uses</li> <li>▪ Hotel Uses</li> <li>▪ Public and Accessory parking</li> <li>▪ Civic/Community and Cultural Uses</li> </ul>	<ul style="list-style-type: none"> <li>▪ M Way (upon completion of later of Blocks M1 and M2; 20-foot pedestrian passage if M1 is completed before M2)</li> <li>▪ Seaport Boulevard Improvements (area adjacent to Block)</li> <li>▪ Other sidewalk improvements (adjacent portions of Seaport Boulevard, East Service Road, B Street)</li> </ul>
BLOCK M2	<ul style="list-style-type: none"> <li>▪ Innovation Uses</li> <li>▪ Retail/Entertainment/ Restaurant/ Services Uses</li> <li>▪ Residential Uses</li> <li>▪ Office and Research Uses</li> <li>▪ Public and Accessory parking</li> <li>▪ Civic/Community and Cultural Uses</li> </ul>	<ul style="list-style-type: none"> <li>▪ M Way (upon completion of later of Blocks M1 and M2; 20-foot pedestrian passage if M2 is completed before M1)</li> <li>▪ Other sidewalk improvements (adjacent portions of East Service Road, B Street and Congress Street)</li> </ul>
BLOCK N	<ul style="list-style-type: none"> <li>▪ Retail/Entertainment/ Restaurant/Services Uses</li> <li>▪ Innovation Uses</li> <li>▪ Civic/Community and Cultural Uses</li> <li>▪ Educational Uses</li> <li>▪ Residential Uses</li> <li>▪ Hotel Uses</li> <li>▪ Office Uses</li> <li>▪ Public and Accessory Parking</li> </ul>	<ul style="list-style-type: none"> <li>▪ Summer Street Steps and accessible route (upon completion of Blocks N or P, whichever earlier)</li> <li>▪ Sidewalk Improvements (adjacent portions of Congress Street, West Service Road and Summer Street)</li> <li>▪ Bicycle Improvements on West Service Road to Melcher Street Extension</li> </ul>

<p>BLOCK P</p>	<ul style="list-style-type: none"> <li>▪ Innovation Uses</li> <li>▪ Retail/Entertainment/ Restaurant/ Service Uses</li> <li>▪ Civic/Community and Cultural Uses</li> <li>▪ Educational Uses</li> <li>▪ Residential Uses</li> <li>▪ Office Uses</li> <li>▪ Hotel Uses</li> <li>▪ Public and Accessory Parking</li> </ul>	<ul style="list-style-type: none"> <li>▪ Sidewalk improvements (Congress Street and Summer Street)</li> <li>▪ Summer Street Steps and accessible route (upon completion of Blocks N or P, whichever earlier)</li> </ul>
----------------	---	---



## EXHIBIT F

### ALLOWED USES

#### Office and Research Uses

##### Office Uses

- Office of professional persons, not accessory to a main use;
- Real estate, insurance, financial service institution, or other agency or government office;
- Office building, post office, bank or similar establishment.

##### Innovation Uses

- Laboratories, small business incubators, and/or facilities for teaching and for theoretical, basic and applied research, product development and testing, prototype fabrication or production of experimental products; vivarium; the keeping of marine life or laboratory animals incidental to a research or development use; storage and office use accessory to a research or development use;
- Design, development, manufacture, compounding, packaging, processing, fabrication, altering, assembly, repairing, servicing, renting, testing, handling, or transfer of products as would be included in research and development uses, consistent with the provisions of Subsection 36-4.1 of the Boston Zoning Code;
- Restaurant and Café wired with communication technology;
- Public event space for exhibitions and presentations;
- Rooftop garden, or other horticultural use;
- Innovation District visitors' center;
- Innovation Businesses
  - i. Innovative Retail: Existing brands in Boston creating new concepts or prototypes or brands new to Boston or local new businesses
  - ii. Innovative Office: flexible, communal, or short-term office space
  - iii. Innovative Hotel: Existing flagship hotels in Boston creating new concepts or prototypes or brands new to Boston
  - iv. Other Innovative Business: New to the Boston market or net new job growth
- Innovation Transportation and Energy
  - i. Car-sharing facilities
  - ii. Bicycle-sharing facilities
  - iii. Electrical vehicle charging station
  - iv. Other infrastructure for sustainable and green transportation
  - v. Facilities or building systems or components for building sustainability, energy efficiency, renewable and clean energy or co-generation of electricity, heat and/or cooling
- Public, common, or shared space within Innovation/Workforce Housing
- Alcoholic Beverage Manufacturing: incl: breweries, distilleries, wineries and attendant tasting rooms, bars, brew pubs or other on-premise or off-premise alcoholic beverage retail uses, with or without food service.

Provided, however, that no laboratory classified by the U.S Centers for Disease Control as Biosafety Level 3 or 4 (“BSL-3” or “BSL-4”) shall be permitted.

## **Residential Uses**

### Residential Uses

- Multi-family residential uses; townhouses.
- Artists' live-work use.
- Convalescent, nursing, or rest home.
- Innovation/Workforce Housing: Co-housing or live-work uses, which may include smaller unit sizes, flexible unit layouts, combined living and working spaces, and common space shared by residents occupying different units.

## **Retail/Entertainment/Restaurant/Service Uses**

### Local Retail/Services Uses

- Store primarily serving the local retail business or service needs of the neighborhood and harbor/waterfront users, including but not limited to chandlery, barber shop, beauty shop, shoe repair shop, self-service laundry, pick-up and delivery station of laundry or dry cleaner, tailor shop, hand laundry;
- Store retailing one or more of the following, but not limited to: food, baked goods, groceries, drugs, tobacco products, clothing, dry goods, books, film, video, art, flowers, paint, hardware, and small household appliances.
- Fitness Center, health club, gymnasium, tennis courts, swimming pool, or other recreational or fitness uses.
- Bank branch, post office.
- Off-premises advertising, signage, billboards.

### General Retail Uses

- Department store, furniture store, general merchandise mart, or other store serving the general retail business needs of a major part of the city, including accessory storage.

### Restaurant Uses

- Lunchroom, restaurant, cafeteria, brew-pub and brewery, or other place for the service or sale of food or drink for on-premises consumption, including outdoor cafes;
- Place for sale and consumption of food and beverages (other than drive-in restaurants) providing dancing or entertainment or both;
- In a structure, sale over the counter, not wholly incidental to a local retail business or restaurant use, of food or drink prepared on premises for off-premises consumption or for on-premises consumption if, as so sold, such food or drink is ready for take-out (other than drive-in restaurants).
- Pushcart food vendors.
- Alcoholic Beverage Manufacturing: incl: breweries, distilleries, wineries and attendant tasting rooms, bars, brew pubs or other on-premise or off-premise alcoholic beverage retail uses, with or without food service.

### Entertainment Uses

- Movie theater
- Bowling alley
- Ice or roller skating Rink

- Live music performance
- Recorded music performance
- Theatre

## **Hotel Uses**

### Hotel Uses

- Hotel (including extended-stay hotel), conference and meeting facilities, restaurant, lounge, bar, store primarily serving the retail needs of hotel, conference, and meeting guests, health club, swimming pool, storage and office use accessory to hotel use.

## **Education/Cultural Uses/Place of Worship**

### Civic/Community Uses and Cultural Facilities

- Museum, gallery, concert hall, theater, auditorium, exhibition space, performance space, aquarium, or historical exhibit open to public generally;
- Community center, community service facility, visitors' center;
- Daycare center.
- Exhibition hall, conference center, meeting facilities, auditorium.
- Place of Worship; monastery; convent; parish house.
- Artist's studio, Art Uses, Artists' Mixed Use.
- Library

### Educational Uses

- Elementary, middle or high school;
- College, university or trade school;
- Education or instructional institution;
- Adult education uses.

## **Open Space Uses**

### Open Space/Recreational Uses

- Open space for active or passive recreational use or dedicated to the conservation of natural resources, including but not limited to parks, public gardens, dog parks and playgrounds; public recreational facilities; publicly accessible garden conservatories or botanical gardens.
- Parks, esplanades, boardwalks, and other pedestrian facilities that promote public use and enjoyment of the water and are located at or near the water's edge;
- Cultural, educational, research, or training facilities focused on open space uses;
- Pavilions open to the public and containing uses accessory to open space uses;
- Sale of food, beverage, and other products accessory to open space uses;
- Art, graphics, sculpture, and signage installations accessory to open space uses;
- Events and other programming that enhances the pedestrian experience.

## **Public Infrastructure Uses**

### Infrastructure Uses

- One or more co facilities for the generation of electricity, heat, and/or cooling.

Public Services Uses

- Public service substation, automatic telephone exchange, fire station, police station;
- Cable conduit, pipeline crossing, stormwater outlet, or other similar utility structure.

Transportation Uses

- Public transportation facility, bus station, subway or trolley station.

**Parking Uses**

Public parking

- Parking garage, including car-sharing and or bicycle-sharing service

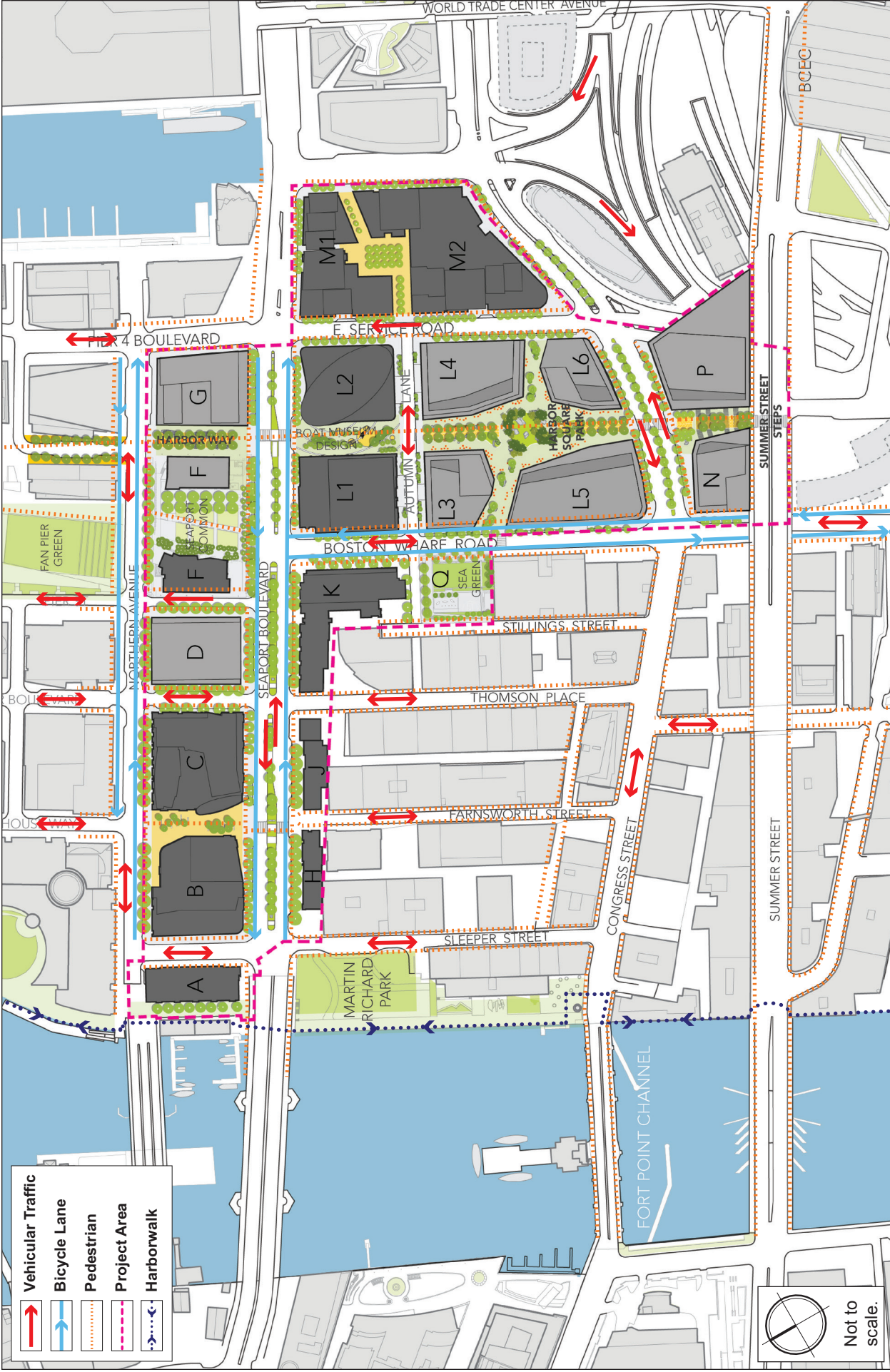
**Accessory and Ancillary Uses**

- Any of the following uses accessory or ancillary to an allowed use, subject to the limitations and restrictions of Article 10:
  - (i) any use accessory or ancillary to, and ordinarily incident to, a lawful main use; provided that such use is not specifically forbidden in the district; and provided further that any such use shall be subject to the same restrictions, conditions, limitations, provisos and safeguards as the use to which it is accessory;
  - (ii) an office, within a main building, of an accountant, architect, attorney, dentist, physician, real estate agent, or other professional person who resides in such building;
  - (iii) an occupation for profit customarily carried on in a dwelling unit by a person residing therein provided that such occupation is carried on in a main building and requires only equipment ordinarily incident to a dwelling unit and that no nonresident help is employed and that there is no trading in merchandise;
  - (iv) the keeping of marine life or laboratory animals incidental to a lawful educational, research center, aquarium, or institutional use;
  - (v) as accessory uses to hotel uses, restaurants, conference facilities, retail and service establishments serving guests and visitors and other uses incidental to the operation of a hotel;
  - (vi) the storage of flammable liquids and gases incidental to a lawful use;
  - (vii) permanent dwellings for personnel required to be resident on a Lot for the safe and proper operation of a lawful main use;
  - (viii) day care center;
  - (ix) health club facility, tennis court, swimming pool;
  - (x) roof deck or outdoor terrace;
  - (xi) Non-Electronic or Electronic sign use, if such signs meet the following requirements: complete design review approval by the BPDA; do not project more than five (5') feet from the face of the building or the width of the sidewalk, whichever is less; are limited to hours of operation between 7:00 AM and 2:00 AM, except that between 2:00 AM and 7:00 AM the sign shall be either off or on sleep mode, displaying abstract imagery that is non-commercial in nature; and have a luminance at night that does not exceed 500 cd/m<sup>2</sup>. If the above requirements are met and such electronic sign(s) have received BPDA approval, then such electronic signs: (i) shall not be required to obtain a conditional use permit from the Board of

Appeal and shall have no time limitation in terms of years of operation/use, except as set forth in a written license agreement with the BPDA, which license agreement shall also include fees to be paid to the BPDA for existence of such electronic signs, other than for signs located on the Innovation Center; and (ii) shall not have an illuminated side facing a residential zoning district listed in Section 3-1.(a) of the Code if located within one hundred fifty (150') feet of such a residential zoning district.

- Parking garage, including car-sharing and/or bicycle-sharing service.
- On-street parking.

EXHIBIT G  
TRANSPORTATION CIRCULATION



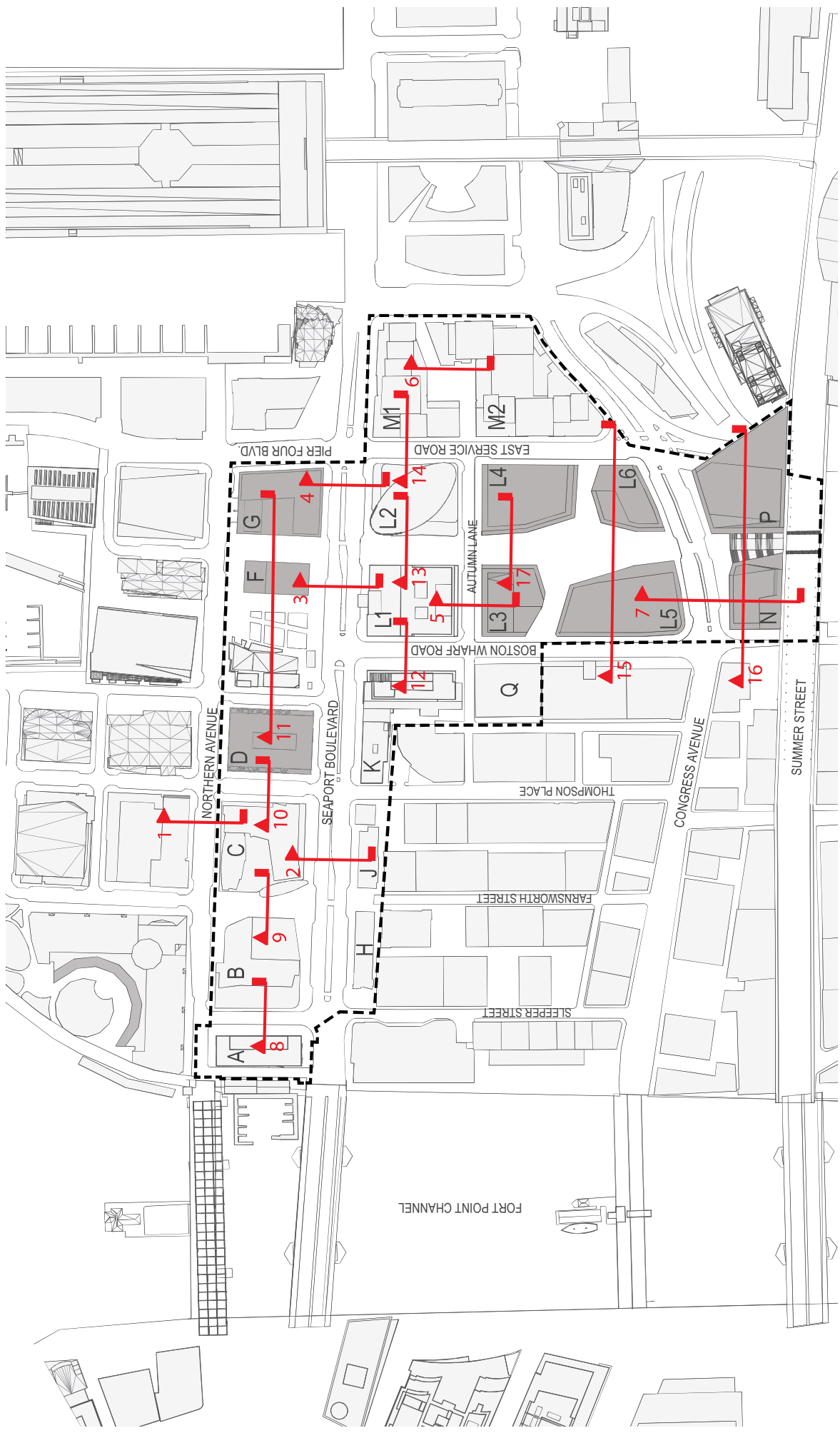
Seaport Square Boston, Massachusetts

# SEAPORT

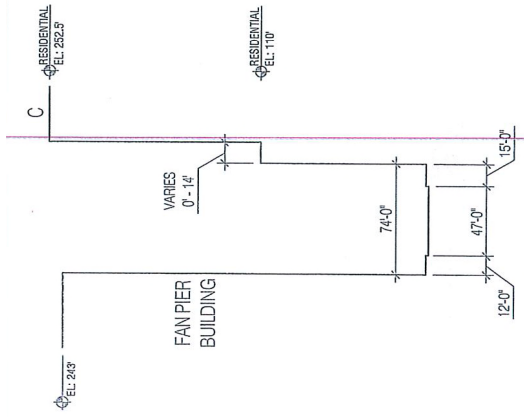
EXHIBIT H

Proposed Street Dimensions

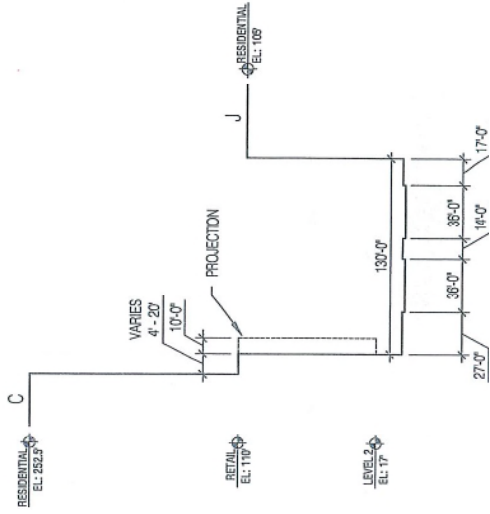




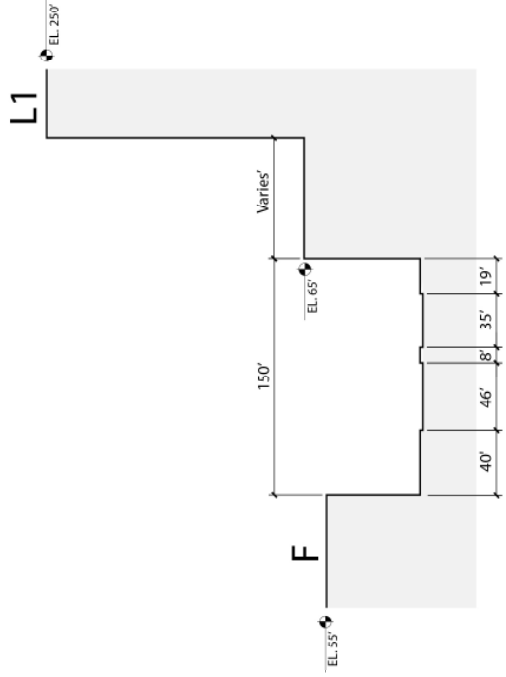
DETAIL SECTION LOCATION #



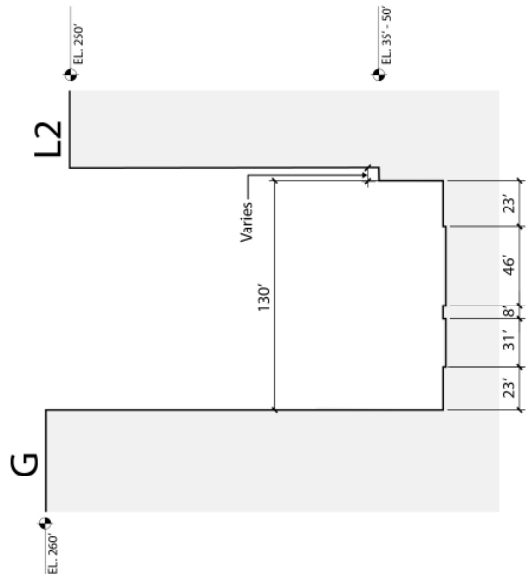
SECTION 1: NORTHERN AVENUE PER SECOND AMENDMENT TO ORIGINAL PDA PLAN



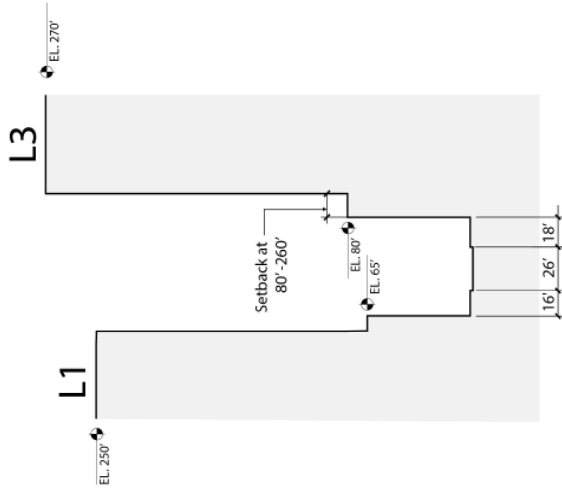
SECTION 2: SEAPORT BOULEVARD PER SECOND AMENDMENT TO ORIGINAL PDA PLAN



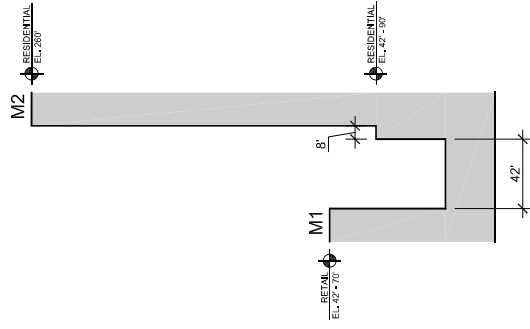
SECTION 3: SEAPORT BOULEVARD



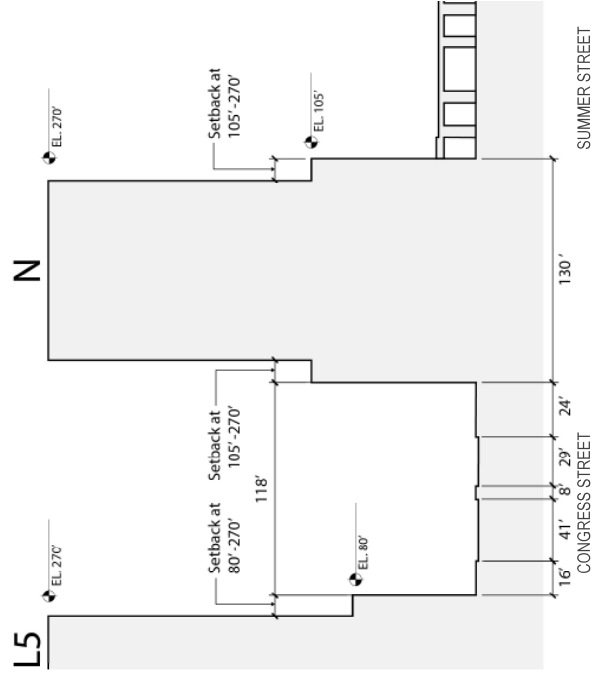
SECTION 4: SEAPORT BOULEVARD



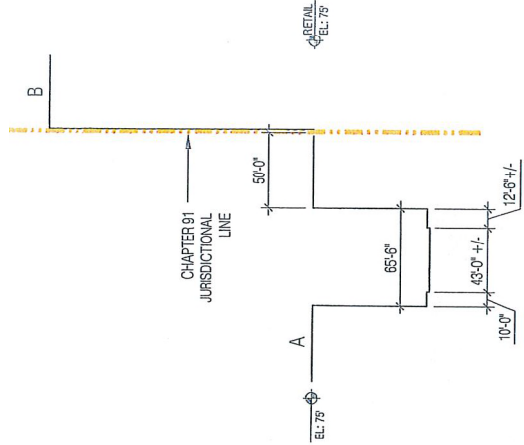
SECTION 5: AUTUMN LANE



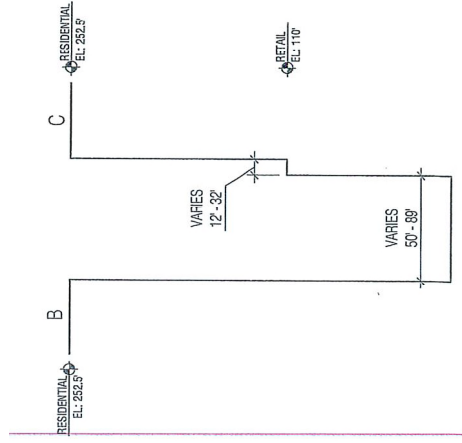
SECTION 6: 'M' WAY PER ORIGINAL PDA PLAN  
(SUPERSEDED BY SIXTH AMENDMENT TO  
ORIGINAL PDA PLAN)



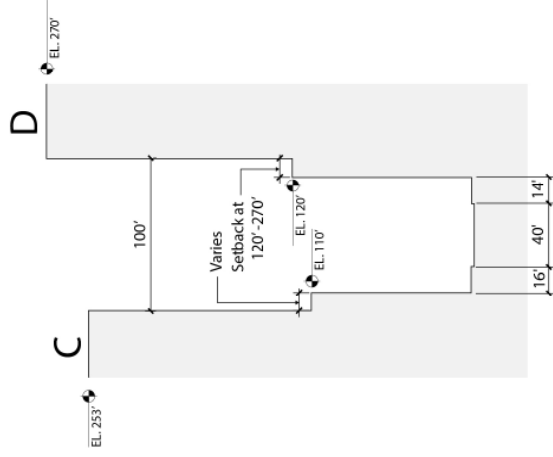
SECTION 7: CONGRESS STREET AND SUMMER STREET



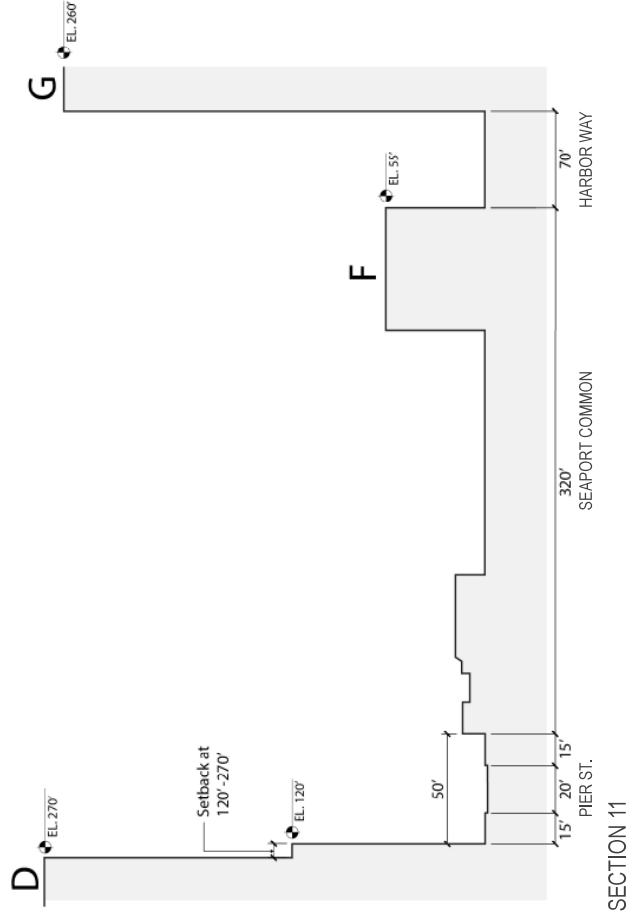
SECTION 8: SLEEPER STREET PER SECOND AMENDMENT TO ORIGINAL PDA PLAN



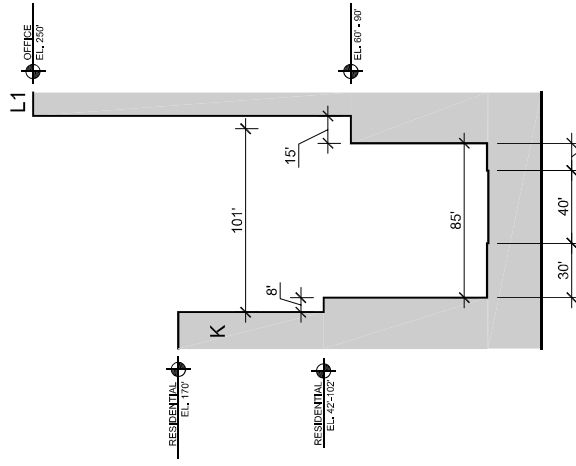
SECTION 9: COURTHOUSE SQUARE PER SECOND AMENDMENT TO ORIGINAL PDA PLAN



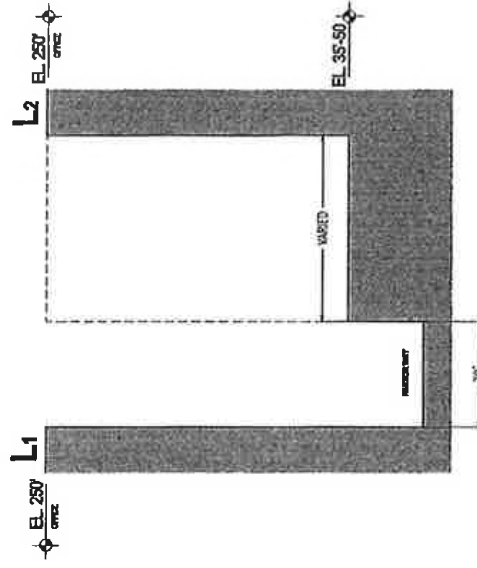
SECTION 10: FAN PIER BOULEVARD



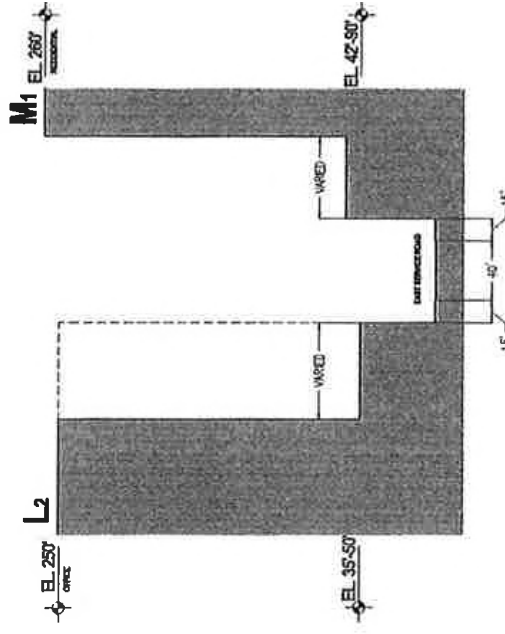
SECTION 11



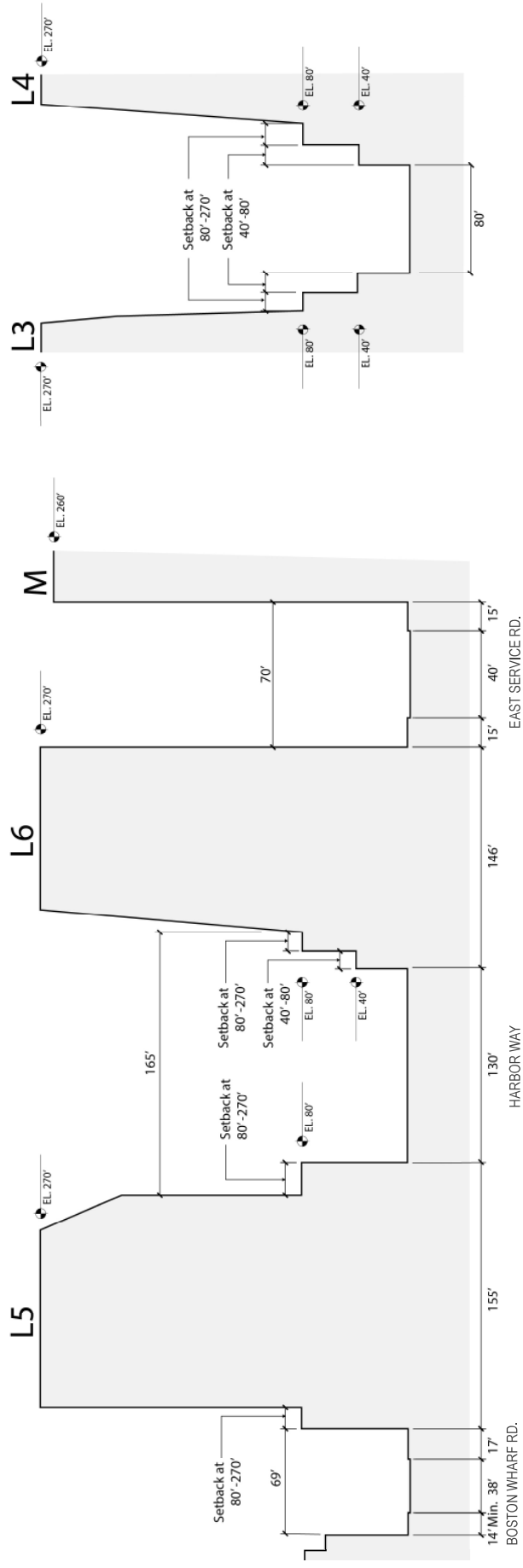
SECTION 12: BOSTON WHARF ROAD



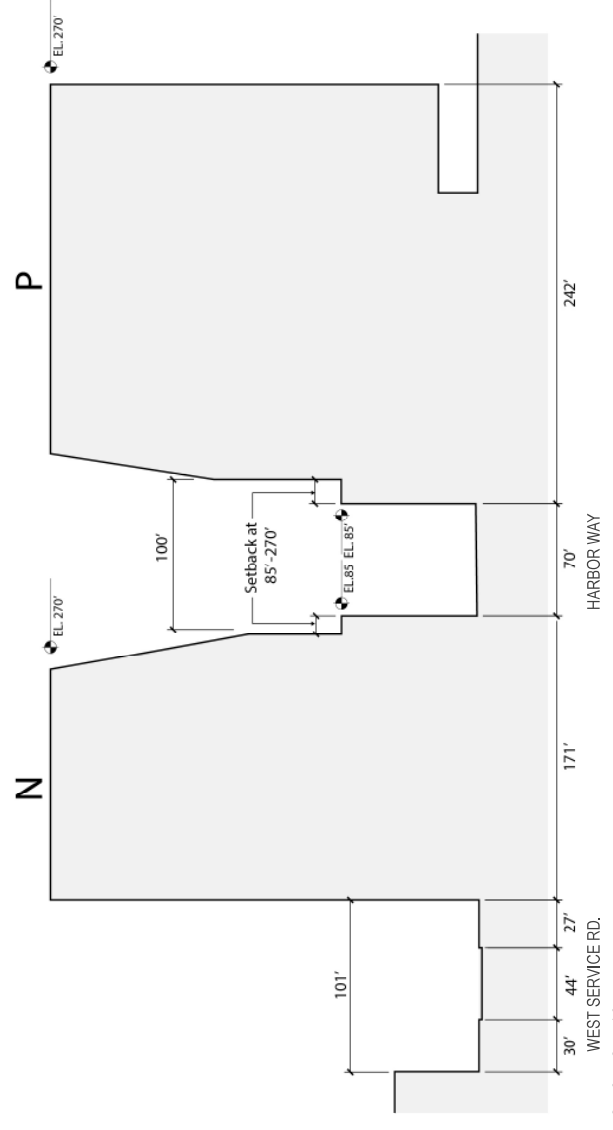
SECTION 13: HARBOR WAY PER FOURTH AMENDMENT TO ORIGINAL PDA PLAN



SECTION 14: EAST SERVICE ROAD PER FOURTH AMENDMENT TO ORIGINAL PDA PLAN

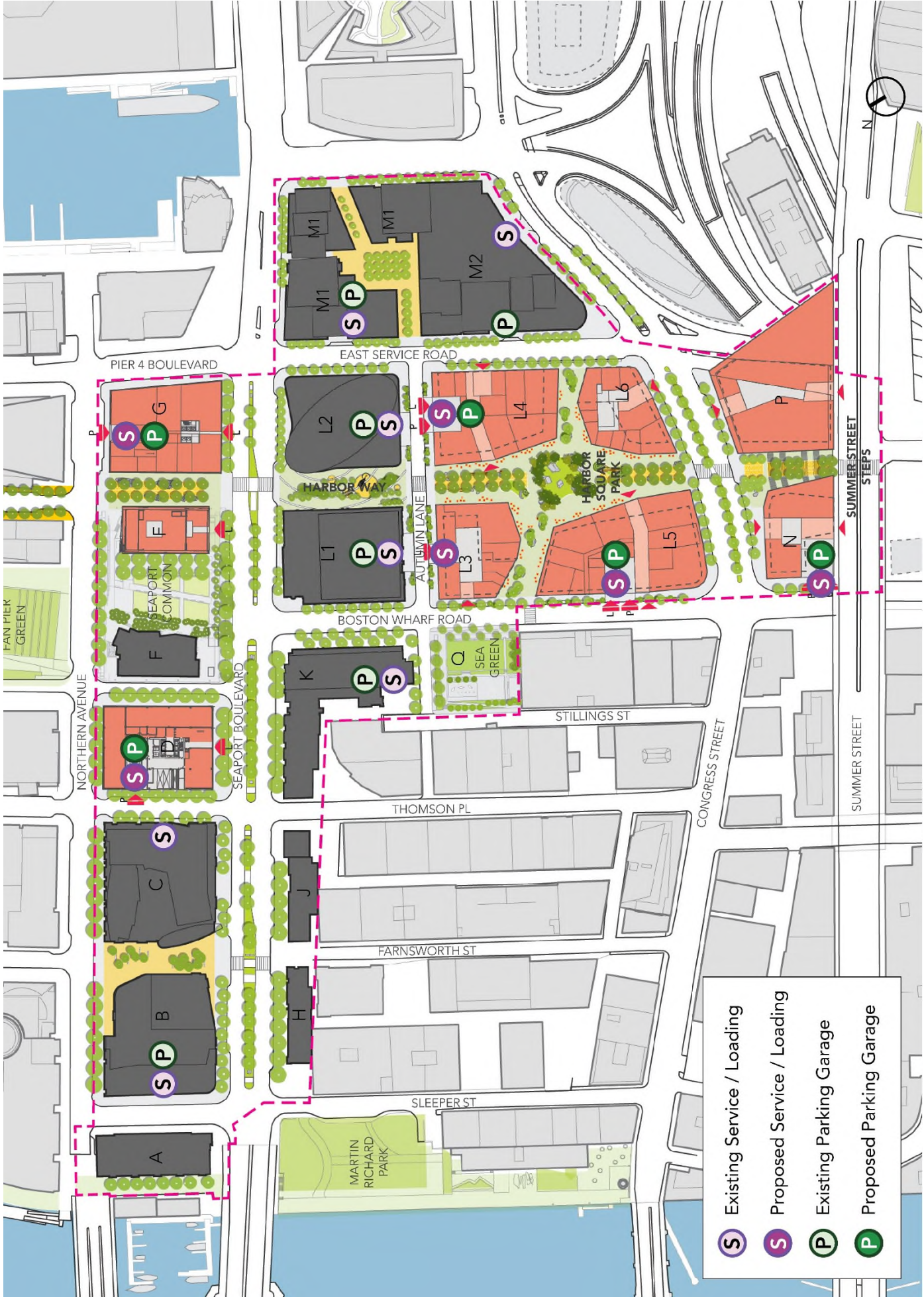


SECTION 17: HARBOR WAY



SECTION 16

EXHIBIT I  
Parking and Loading



Seaport Square Boston, Massachusetts



## Fact Sheet

### Application for Approval of Amended and Restated Planned Development Area Development Plan

#### **Seaport Square Project, South Boston**

<u>Board Action</u>	The Proponent is requesting the Authority’s approval of an Amended and Restated Development Plan for Planned Development Area No. 78 (the “ <u>Amended and Restated PDA Plan</u> ”) for the Seaport Square project (the “ <u>Project</u> ”) a portion of which has been constructed, and a portion of which shall be constructed, on the site located in South Boston, Massachusetts.
<u>Proponent</u>	Seaport Square Development Company LLC, a Delaware corporation, and its affiliates.
<u>Site</u>	The Planned Development Area (“ <u>PDA Area</u> ”) will consist of approximately 33.5 acres in the South Boston Waterfront District. A property description is attached as <u>Exhibit A</u> .
<u>General Description of Proposed Project</u>	The Amended and Restated PDA Plan would supersede the existing Planned Development Area Plan for PDA No. 78, Seaport Square Project, as previously amended (the “ <u>Original PDA Plan</u> ”), to allow changes to approximately nine of the previously-approved twenty development blocks, which remain undeveloped and are largely occupied by surface parking lots, as well as modifications and enhancements to the public realm improvements and public benefits to be provided in conjunction with the development of those undeveloped blocks. The Amended and Restated PDA Plan would allow an increase in the total gross floor area of the Project from approximately 6.3 million square feet to approximately 7.7 million square feet, which would include a total of approximately 3.2 million square feet of residential uses, 2.8 million square feet of office/research/innovation uses, 1.1 million square feet of retail/entertainment/performing arts uses, 480,000 square feet of hotel uses, 19,700 square feet of civic uses, as well as cultural/community uses. Approximately 5,500 underground parking spaces, reduced from approximately 6,375 spaces in the original project, and approximately 200 on-street parking spaces, are proposed. Approximately 39% of the development site will be dedicated to open space, including three signature public spaces.
<u>Anticipated Job Creation</u>	The Project has created and will create a total of approximately 12,000 construction jobs and approximately 23,000 permanent jobs. The permanent jobs will be created through the retail stores, office and research uses, hotels, and services related to the residential uses.
<u>Project Impact Project Contribution</u>	The Project has generated and will generate a total of approximately \$41,500,000 in housing and jobs linkage funds to the City of Boston. Notably, this linkage payment will be the largest linkage payment ever made to the City of Boston to date.

## Zoning

Nearly all of the PDA Area is already located within PDA No. 78 pursuant to the Original PDA Plan; the boundaries of the PDA Area will be adjusted to result in an increase from 1,444,765 square feet to 1,460,572 square feet. The PDA Area is also located within the Fort Point Waterfront Subdistrict of the Harborpark District governed by Article 42E of the Code, except for Block Q and the southern portion of Block K, which are within the M-4 Restricted Manufacturing Subdistrict, and the southern half of Summer Street, which is outside of the Harborpark District and within an I-2 Industrial Subdistrict. The entire PDA Area is within the Restricted Parking Overlay District. Blocks H, J, K and Q are within the Groundwater Conservation Overlay District. Portions of certain blocks are designated as special flood hazard areas, Zone AE, on the Suffolk County Flood Insurance Rate Map issued by the Federal Emergency Management Agency, and are thus within a flood hazard special purpose overlay district and subject to the regulations set forth in Article 25 of the Code. Planned Development Areas are allowed on all portions of the PDA Area.

EXHIBIT A  
LEGAL DESCRIPTION

**PLANNED DEVELOPMENT AREA DESCRIPTION  
SEAPORT SQUARE**

The Limits of Seaport Square Planned Development Area are bounded and described as follows:

Beginning at the point of intersection of a line that is about 21 feet north of the northerly line of Block G and 18 feet east of the easterly line of Block G;

Thence running southwesterly about 18 feet east of the easterly line of Block G to a point about 22 feet north of the southerly line of Seaport Boulevard;

Thence running easterly about 22 feet north of Seaport Boulevard to a point about 22 feet easterly of B Street;

Thence running southerly about 22 feet east of B Street to a point 24 feet south of the northerly line of Congress Street;

Thence running southwesterly about 24 feet south of the northerly line of Congress street to a point on the easterly sideline of Air Rights Block P;

Thence running southwesterly along the easterly sideline of Air Rights Block P;

Thence running northwesterly along the southerly sideline of Air Rights Block P;

Thence running southerly about 58 feet east of the westerly sideline of East Service Road to a point 9 feet south of the southerly line of summer street;

Thence running northwesterly about 9 feet south of the southerly line of summer street to a point 11 feet west of the easterly line of West Service Road Extension;

Thence running northeasterly about 11 feet west of the easterly line of West Service Road Extension over Congress Street, and continuing northeasterly about 10 feet west of Boston Wharf Road to a point;

Thence running northwesterly by the southerly sideline of Block Q to a point 11 feet west of the easterly sideline of Stillings Street;

Thence running northeasterly 11 west of the easterly sideline of Stillings Street to a point at the sideline of Block K;

Thence running northwesterly by the southerly lines of Block K, MBTA, Block J, BRA, and Block H to a point 24 feet west of the easterly line of Sleeper Street;

Thence running northeasterly to a point 13 feet south of the northerly sideline of Seaport Boulevard to a point;

Thence running northwesterly 13 feet south of the northerly sideline of Seaport Boulevard to a point 41 feet west of the westerly line of Block A;

Thence running northeasterly 41 west of the westerly line of Block A to a point 60 north of the southerly sideline of Northern Avenue;

Thence running southwesterly in Northern Avenue to a point 20 feet north of the southerly sideline of Northern Avenue and 10 feet east of the westerly sideline of Sleeper Street;

Thence running southeasterly 20 feet north of the southerly sideline of Northern Avenue to the point of beginning.

Together with any fee or easements that Proponent has or may acquire from MassDOT with respect to Air Rights Block P.

The above described Planned Development Area contains approximately 1,460,572 square feet (approximately 33.5 acres) and is shown on the plan titled "Planned Development Area, Seaport District South Boston, Boston, Massachusetts" dated January 2017, prepared by Nitsch Engineering.

## **LEGAL NOTICE**

The Boston Redevelopment Authority d/b/a the Boston Planning & Development Agency ("BRA"), pursuant to Article 80 of the Boston Zoning Code, hereby gives notice that an Amended and Restated Development Plan for Planned Development Area No. 78, Seaport Square Project, South Boston ("Amended and Restated PDA Plan") was submitted pursuant to Section 80C-5 and Section 80C-7 on September 15, 2017, by Seaport Square Development Company LLC and its affiliates (the "Proponent") for the Seaport Square project (the "Proposed Project"), located on approximately 23 acres of land in South Boston generally bounded by Northern Avenue and Seaport Boulevard (between Old Sleeper Street and Pier 4 Boulevard) and by Stillings Street, Boston Wharf Road, East Service Road and Pier 4 Boulevard and B Street (between Seaport Boulevard and Summer Street) (the "**Project**"). The site that is the subject of the Amended and Restated PDA Plan has an area of approximately 1,460,572 square feet (33.5 acres). The Amended and Restated PDA Plan would supersede the existing Planned Development Area Plan for Planned Development Area No. 78, to allow changes to approximately nine of the previously-approved twenty Blocks, which remain undeveloped and are largely occupied by surface parking lots, as well as modifications to the public realm improvements and public benefits to be provided in conjunction with the development of those undeveloped Blocks. The Amended and Restated PDA Plan would allow an increase in the total gross floor area of the Project from approximately 6.3 million square feet to approximately 7.7 million square feet, which would include approximately 3.2 million square feet of residential uses, 2.8 million square feet of office/research/innovation uses, 1.1 million square feet of retail/entertainment/performing arts uses, 480,000 square feet of hotel uses, 19,700 square feet of civic uses, as well as cultural/community uses. Approximately 5,500 underground parking spaces, reduced from approximately 6,375 spaces in the original project, and approximately 200 on-street parking spaces are proposed.

Approvals are requested of the BRA pursuant to Article 80 to approve the Amended and Restated PDA Plan and to authorize the Director of the BRA to petition the Zoning Commission to approve the Amended and Restated PDA Plan and the associated map amendment. The Amended and Restated PDA Plan may be viewed at the following locations: Office of the Secretary of the BRA, Room 910, Boston City Hall, One City Hall Square, Boston, MA 02201 (Monday through Friday, 9:00 a.m. to 5:00 p.m.), except legal holidays; and the South Boston Branch Library, 646 East Broadway (open Monday and Thursday between 12:00 p.m. and 8:00 p.m., Tuesday and Wednesday between 10:00 a.m. and 6:00 p.m., and Friday between 9:00 a.m. and 5:00 p.m.). Public comments on the NPC should be transmitted to Michael Rooney, Project Manager, BRA, at the address stated above by October 30, 2017.

BOSTON REDEVELOPMENT AUTHORITY  
Teresa Polhemus  
Executive Director/Secretary