

BEA Annual: 11/14/01  
ZC Annual: 2/15/02  
EMERILE: 2/28/02

**APPENDIX A**

**DEVELOPMENT PLAN**

**FAN PIER DEVELOPMENT**

**28-52 Northern Avenue, Boston**

**Introduction**

In accordance with Section 80C-3 of the Boston Zoning Code (the "Code"), this development plan sets forth information on the Fan Pier Development (the "Development") at 28-52 Northern Avenue, including the proposed location and appearance of structures, open spaces and landscaping, the proposed uses of the Development, the proposed dimensions of structures, the proposed densities, the proposed traffic circulation, parking and loading facilities, access to public transportation and other major elements of the Development (the "Development Plan"). This Development Plan, including the Exhibits attached hereto, is subject to continued design, environmental, and development review by the Boston Redevelopment Authority (the "Authority") and other governmental agencies. In accordance with Section 80C-8 of the Code, a building, use or occupancy permit for the Development shall not be issued until the Director of the Authority shall have issued a Certification of Consistency pursuant to Section 80C-8 of the Code, and such Certification of Consistency shall be a conclusive determination of compliance with the terms and conditions of this Development Plan.

**Developer**

The developer of the Development is Fan Pier Land Company, a Delaware corporation, its successors and assigns (the "Developer").

The business address, telephone number and designated contact for the Developer are:

Fan Pier Land Company  
c/o Spaulding & Slye Colliers  
255 State Street  
Boston, MA 02109  
617-523-8000

Contact persons:

Daniel O'Connell  
Kyle Warwick

## Project Area

The site proposed for the Development (the "Project Area") is a rectangular site, approximately 909,799 square feet in area (20.9 acres), including 643,080 square feet of land (14.8 acres) and 266,719 square feet of water (6.1 acres), located at 28-52 Northern Avenue in Boston, Massachusetts, as more particularly described in Exhibit A (the "Project Area"). The Project Area is currently vacant and is used as a surface parking facility. The Project Area abuts the Boston Inner Harbor to the north, the Moakley Federal Courthouse to the west, Northern Avenue to the south, and Pier 4 to the east.

## General Description of the Proposed Development

Nine new buildings will be constructed. They will contain residential, office, hotel, retail and civic uses, with ancillary parking. Four of the buildings will be primarily residential, three will be primarily office and one will be primarily hotel. Each of those buildings will contain retail uses on the lower floors and two of them will also contain civic uses on the lower floors. The ninth building will be entirely dedicated to civic uses. Together the nine buildings will contain a total of 2,927,000 square feet of residential, office, hotel and retail space, together with 107,000 square feet of civic space. A breakdown of the anticipated square footage and uses of each of the nine buildings is contained in Figure 1 of Exhibit B.

The building dedicated to civic uses will contain the new home of the Institute of Contemporary Art. The civic space in the office building will be an interactive learning center for families and children sponsored by the Children's Museum. The civic space in the residential building will be a children's aquarium and Boston Harbor Islands gateway sponsored by the New England Aquarium and the Island Alliance. The Boston Redevelopment Authority must approve any changes in these civic uses.

The project will contain 263,000 square feet of open space (excluding streets) that will be publicly accessible at all times. This public open space will include two major parks: one located along the curved edge of the Fan Pier (Fan Pier Park) and one located between Northern Avenue and the Fan Pier cove (Public Green). It will also include a Harborwalk along the entire waterfront edge of the Project Area. The general arrangement of open space and streets is illustrated in Figure 1 of Exhibit B.

The cove will be made suitable for water transportation and water recreation uses by the construction of a wave attenuation structure (breakwater) and by dredging the cove to an appropriate depth. Water transportation will be supported by a fixed pier of approximately 160 linear feet and by on-site ticketing and waiting areas. Water recreation opportunities will be provided by transient docking slips and by a public "touch and go" dock. The general arrangement of water transportation and water recreation facilities is illustrated in Figure 1 of Exhibit B.

Parking will be provided by 2,285 underground parking spaces and 40 on-street, short-term parking spaces.

A list of the permitted uses on the site is set forth on Exhibit C.

**Proposed Dimensions, Form and Appearance of Structures**

The Municipal Harbor Plan prepared by the Boston Redevelopment Authority, and approved with qualifications by the Secretary of Environmental Affairs, establishes several dimensional, locational and design requirements for buildings within the Project Area as follows:

- Total building footprints within the Project Area may not exceed 44% of the total site area
- Buildings must be set back specified minimum distances from the water's edge as follows:

Curved Edge of Fan Pier	150 feet
Cove Edge (general)	60 feet
Cove Edge (ICA only)	30 feet
- Buildings must be located so as to ensure minimum dimensions of the two major parks within the Project Area:

Minimum depth of Fan Pier Park	150 feet
Minimum width of Public Green	270 feet
- View corridors to the water must be preserved
- Taller buildings must maintain a street wall of 75-85 feet
- Taller building elements may not have floorplates exceeding 25,000 square feet
- Maximum building heights are established for each building parcel as follows:

Parcel A	244 feet
Parcel B	239 feet
Parcel C	175 feet
Parcel D	175 feet
Parcel E	236 feet
Parcel F	237 feet
Parcel H	175 feet
Parcel I	226 feet
Parcel J	75 feet
- Total gross floor area may not exceed 2,927,000 square feet of non-civic space and 107,000 of civic space

Figures 2 to 10 of Exhibit B provide conceptual plans for each of the nine buildings. These conceptual plans conform to the dimensional, locational and design requirements of the Municipal Harbor Plan, as approved. Because the Municipal Harbor Plan requirements (taken together) limit building design, these conceptual plans reflect the likely location and general massing of the nine buildings. Separate designers will give each building a separate architectural expression. Given the current conceptual state of the plans, further architectural plans, including schematic and design development plans, must be reviewed by the Boston Civic Design Commission and approved by the Boston Redevelopment Authority in accordance with its Development Review Procedures (1985, rev. 1986) before any contract documents are submitted

for review and approval. All buildings, as further designed, shall continue to comply with the terms of this Development Plan and of the Municipal Harbor Plan, as approved.

### **Open Spaces and Landscaping**

**Parks.** The Development includes two new waterfront parks: Fan Pier Park (alongside Boston Inner Harbor) and the Public Green (between Northern Avenue and the southern edge of the Fan Pier cove), as illustrated in Figure 1 of Exhibit B. Fan Pier Park will contain a tidal cove feature developed with input from the New England Aquarium. The eastern portion of Fan Pier Park is a terrace and lawn that will include a small pavilion with public restrooms and showers. The Public Green will connect the land side of Fan Pier to the harbor by allowing views and physical access to the Fan Pier cove and the waterfront directly from Northern Avenue and from the Courthouse Station stop on the new MBTA Silver Line. It will contain green landscaped areas, benches and pedestrian paths. The two parks will be accessible to the public 24 hours a day and will have public amenities, including bathrooms, phones and benches.

**Harborwalk.** Harborwalk will be extended along the entire waterfront edge of the Project Area as part of the Development. The Harborwalk is located along meandering pathways within Fan Pier Park and along a boardwalk pier following the Fan Pier cove perimeter. A publicly accessible floating pier of approximately 640 feet in length will extend into the Fan Pier cove, supported by the wave attenuation structure. The general arrangement of the Harborwalk is illustrated in Figure 1 of Exhibit B.

**Sidewalks/Streetscape.** The Development will extend the local street and sidewalk grid into the Project Area. The design of the sidewalks and streetscape will emphasize their public nature. Along Northern Avenue, new sidewalks will be constructed as buildings along the street are completed. Trash receptacles and plantings will be included in the streetscape plan. Lighting will be provided to maintain a safe, inviting environment for 24-hour public accessibility

These improvements will be designed in conjunction several City of Boston agencies, including the Public Improvements Commission, the Boston Transportation Department and the Parks and Recreation Department. The landscaping and streetscape improvements will be subject to review and approval by the Boston Redevelopment Authority.

### **Proposed Traffic Circulation**

The general arrangement of streets and sidewalks is illustrated in Figure 1 of Exhibit B. The principal access routes for vehicles, upon completion of the Central Artery/Tunnel project, will be from New Northern Avenue via Pittsburgh Street, West Service Road and East Service Road. Principal vehicular egress routes will be to New Northern Avenue via Sleeper Street and West Service Road.

The Developer will promote transportation demand management strategies designed to reduce auto dependency of people who travel to and through the Fan Pier in consultation with the Boston Transportation Department. These strategies may include emergency ride home

programs, hotel reservation systems that encourage guests to utilize the public transit options to and from the airport, an on-site rental car facility and advocacy of car sharing programs such as "Zipcar." The Development will support such options by the inclusion of shuttle shelters and waiting areas and preferential carpool/vanpool parking.

Specifics of traffic circulation and transportation demand management will be developed in consultation with the Boston Transportation Department and included in a Transportation Access Plan Agreement and Construction Management Plan.

### **Parking and Loading Facilities**

The Development will include 2,285 spaces of below-grade parking located in two parking facilities. The West Garage will contain approximately 1,540 parking spaces and the East Garage will contain approximately 745 parking spaces. There will also be 40 on-street, short-term parking spaces. Parking will be priced at market to encourage the use of alternative transportation options. Loading may be at or below grade. Specific parking and loading layouts will be developed in consultation with the Boston Transportation Department and included in the Transportation Access Plan Agreement and Construction Management Plan.

### **Public Transportation Access**

The principal means of public transportation to the South Boston Waterfront and the Development will be the MBTA's new Silver Line, projected to go on line in 2003. Courthouse Station will be located across the street from the Public Green and a short walk from the water transportation facilities on the Fan Pier cove.

The Fan Pier water transportation pier will provide berths for commuter service vessels capable of serving Quincy and/or Hingham on the South Shore and Lynn or Salem on the North Shore. It will also provide berths for inner-harbor vessels, potentially connecting the South Boston Waterfront with North Station/Lovejoy Wharf, Lewis Mall (East Boston), Charlestown, Long Wharf and Hyatt Harborside Hotel/Logan Airport.

The Development will also be served by local surface bus routes. A bus stop/shelter may be constructed along Northern Avenue if appropriate to support such service. As needed, supplemental shuttles may be made available to connect the Development with key local access points such as South Station, North Station and Logan Airport.

Specifics of public transportation access will be developed in consultation with the Boston Transportation Department and included in a Transportation Access Plan Agreement and Construction Management Plan.

### **Pedestrian/Bike Access**

The extension of the local street and sidewalk grid into the Project Area will provide pedestrian access throughout the site. Harborwalk will make a direct connection with the open space at the Moakley Federal Courthouse, allowing a continuous waterfront walk to the Financial District and beyond. The Public Green provides a pedestrian route from the Fan Pier cove to the MBTA's new Courthouse Station. The Development will also serve as the waterfront terminus of the proposed pedestrian/bike South Bay Harbortrail, which will lead to the site from Roxbury, the South End and along the Fort Point Channel. The Development will contain bike racks and showers for bicycle commuters and others.

### **Sequencing of the Development**

The Project Area naturally breaks down into two areas of development. The western portion of the site includes the hotel, four residential buildings, and the western office building. The western portion also includes the associated streets and sidewalks, Fan Pier Park, the westerly side of the Public Green, Harborwalk and the cove breakwater. The eastern portion of the site includes the two eastern office buildings and the ICA. Eastern portion amenities include the associated streets and sidewalks, Harborwalk, all improvements to the south side of the Cove, and the easterly half of the Public Green. The water transportation pier will be constructed at the beginning phase of the project. The temporary Harborwalk that is in place along the entirety of the water's edge will remain open throughout construction to the maximum extent feasible. Some marine and open space construction work may require temporary re-routing of Harborwalk.

The target date for completion of the entire Development will depend upon continued market demand for the uses contemplated, the availability of construction labor and materials, and stability in the larger economy. As more precise construction sequencing plans are developed, they shall be submitted to the Boston Redevelopment Authority for confirmation and approval.

### **Zoning**

The Project Area is located within the South Boston Inner Harbor Subdistrict of the South Boston Seaport Interim Planning Overlay District established under Article 27P of the Zoning Code. The zoning underlying the South Boston Seaport IPOD is the Fort Point Waterfront section of the Harborpark District established under Article 42E of the Zoning Code.

Article 27P allows the establishment of Planned Development Areas within the South Boston Inner Harbor Subdistrict. This Development Plan meets the public benefits criteria of Section 27P-16(2) in that it will create new permanent jobs, it will create new housing opportunities, it will provide substantial new waterfront public facilities and accessible public open space and it will activate the now unused Fan Pier cove. This Development Plan also complies with the applicable requirements of the Municipal Harbor Plan, as approved, as required by Article 27P. In addition, the Development Plan complies with the standards set forth under Section 27P-15 for a favorable Chapter 91 recommendation by the BRA.

If the Project is constructed in accordance with this Development Plan, no exceptions from the Zoning Code will be required under Article 6A. This Development Plan shall constitute permanent zoning for the Project Area, within the meaning of the Municipal Harbor Plan, as approved. No Interim Planning Permit under Section 27P-18 shall be necessary for any work in accordance with this Development Plan.

The Project Area may be severed into several parcels in the future to permit entering into financial arrangements on individual buildings or for other reasons. For the purpose of zoning, any such severance shall be deemed consistent with this Development Plan. In the case of any such severance, a Certification of Consistency may be issued for any such parcel as a conclusive determination of its compliance with the terms and conditions of this Development Plan.

### **Development Review Procedures**

The Development is subject to Large Project Review under Section 80B-1 *et seq.* of the Code. In April 2000, the Developer submitted a Draft Project Impact Report ("DPIR") for the Development. The Development was revised to comply fully with the Municipal Harbor Plan as approved by the Secretary of Environmental Affairs and to reflect the numerous public comments and dialogue that took place. In July 2001, the Developer submitted the Final Project Impact Report ("FPIR") for the Development.

Final plans and specifications (i.e., contract documents) for any portion of the Development shall be subject to review and approval by the Authority in accordance with its Development Review Procedures (1985, rev. 1986). The final plans and specifications, as approved by the Authority, shall be deemed to be consistent with this Development Plan and to have addressed all design requirements set forth in Section 27P-14 of the Zoning Code.

Given the scope of this proposed Development, and as a result of the various reviews of the Development necessary to secure all required permits and approvals, modifications may have to be made. Minor modifications which affect site improvements, exterior facades, roofscape or public spaces will be subject to the approval of the Director of the Authority under this Development Plan without further Authority action, unless the Director determines that the changes are not consistent with this Development Plan.

### **Proposed Public Benefits**

**Housing Contribution.** As required under Section 80B-7(3)(a) of the Boston Zoning Code, the Developer will enter into a Development Impact Project Agreement with the Boston Redevelopment Authority (the "DIP Agreement") and will be responsible for contributing a Housing Exaction with regard to the Development. The Housing Exaction shall be contributed, at the Developer's option, by: (i) the grant and payment by the Developer of a sum of money payable at the times and in the manner and under the conditions specified in the DIP Agreement (referred to in said Section 80B-7(3)(a) as the "Housing Contribution Grant"), (ii) the creation by the Developer of low and moderate income housing units at a cost at least equal to the amount of

the Housing Contribution Grant and under the conditions specified in the DIP agreement (referred to in said Section 80B-7(3)(a) as the "Housing Creation Option"), or (iii) a combination of items (i) and (ii) above.

Should the Development's obligation with regard to the Housing Exaction for all of the buildings included in this Development Plan be satisfied solely in the form of a Housing Contribution Grant, total payments from the Development would equal approximately \$9,529,542, calculated on the basis of 1,835,800 square feet of commercial development (less a one-time 100,000 square foot exemption) times a contribution rate of \$5.49 for each square foot of development. Payments would be allocated to individual buildings in accordance with their respective square footage, with the 100,000 square foot exemption being applied to the first building for which a building permit is issued. Subject to approval of the Neighborhood Housing Trust and the Boston Redevelopment Authority, the Developer anticipates contributing the Housing Exaction by utilizing the Housing Creation Option.

**Jobs Contribution.** As required under Section 80B-7(3)(b) of the Boston Zoning Code, the Development will also be responsible for contributing a Jobs Contribution Exaction with regard to the project. The Jobs Contribution Exaction shall be payable at the times, in the manner and under the conditions specified in the DIP Agreement. It is anticipated that the total Jobs Contribution Exaction will equal \$1,892,022, calculated on the basis of 1,835,800 square feet of commercial development (less a one-time 100,000 square foot exemption) times a contribution rate of \$1.09 for each square foot of development..

**Affordable Housing Contribution.** This Development Plan will not receive a certification under Section 42E-18 of the Boston Zoning Code unless the Development either (i) ensures that at least ten percent (10%) percent of the dwelling units proposed in the Development Plan are affordable, or (ii) makes grants for the creation, preservation, or rehabilitation of housing units off-site equivalent to twenty percent (20%) of the number of market rate housing units constructed on the site. The Developer anticipates creating both on-site and off-site affordable housing in order to meet this standard.

**Taxes.** Upon completion of full build, the Development will contribute an estimated \$15 to \$20 million per year in property taxes, in comparison with current real estate taxes on the property of \$250,000.

**Jobs.** Construction of the Development will create an estimated 1,750 union construction jobs. A Boston Residents Construction Employment Plan ("BRCEP") will be submitted in accordance with the Boston Jobs Policy. Under the BRCP the Developer will make good-faith efforts to ensure that Boston residents work at least 50% of the total employee hours, minorities work at least 25% of the total employee hours, and women work at least 10% of the total employee hours. The hotel component alone of the Development will create approximately 550 jobs for workers with diverse skills and educational backgrounds. The companies leasing space in the office buildings will create a significant number of professional and support jobs. The



Developer will enter into a First Source Agreement and Memorandum of Understanding outlining good-faith efforts to ensure that 50% of the permanent employees in the Development are Boston residents.

**Daycare Facilities.** On site space will be set aside for daycare facilities, in compliance with City of Boston requirements.

**Public Amenities.** The Development will include major new public amenities for the South Boston Waterfront District, including two waterfront parks, new facilities for water transportation and recreation, an extensive addition to Harborwalk and new civic and cultural facilities, all as described above.

**Infrastructure Improvements.** Construction of the Development will include new streets and sidewalks, as described above, along with improvements to utility and stormwater discharge systems.

**EXHIBIT A  
PROJECT AREA**

Three certain parcels of land located on the northerly side of Northern Avenue in Boston, Suffolk County, Massachusetts, being shown as Lot 1B, Remainder of Lot A and Lot B on "Compiled Plan of Land in Boston, Massachusetts - South Boston District - Scale 1:960 - 7 December 1995" by Gunther Engineering, Inc. said lots being together bounded and described as follows:

Beginning at a point on the northerly sideline of Northern Avenue located 345.29 feet southeast of a stone bound situated on the northerly sideline of Northern Avenue, said point being the southwesterly corner of the parcel; thence running:

- ◆ NORTH 31° 53' 17"
- ◆ EAST 667.56 feet by Lot 1A on the Plan to a point; thence running
- ◆ NORTHEASTERLY 275.30 feet by a curve to the right having a radius of 910.00 feet to a point; thence continuing
- ◆ NORTHEASTERLY 400.00 feet by a curve to the right having a radius of 2370.00 feet to a point of tangency; thence turning and running
- ◆ SOUTH 61° 20' 09"
- ◆ EAST 440.11 feet, said last three courses being by the pier and bulkhead line of 1916 (abandoned); thence turning and running
- ◆ SOUTH 29° 46' 06"
- ◆ WEST 1,004.85 feet by land of now or formerly of Pier Four, Inc. to a point on the northerly sideline of Northern Avenue; thence turning and running
- ◆ NORTH 34° 06' 20"
- ◆ WEST 381.13 feet by said Northern Avenue to a point on the northerly sideline of Northern Avenue; thence turning and running
- ◆ NORTH 58° 06' 43"
- ◆ WEST 779.05 feet by Northern Avenue to the point of beginning.
- ◆ Containing 20.887 acres, more or less, according to the Plan.

**EXHIBIT B  
DRAWINGS**

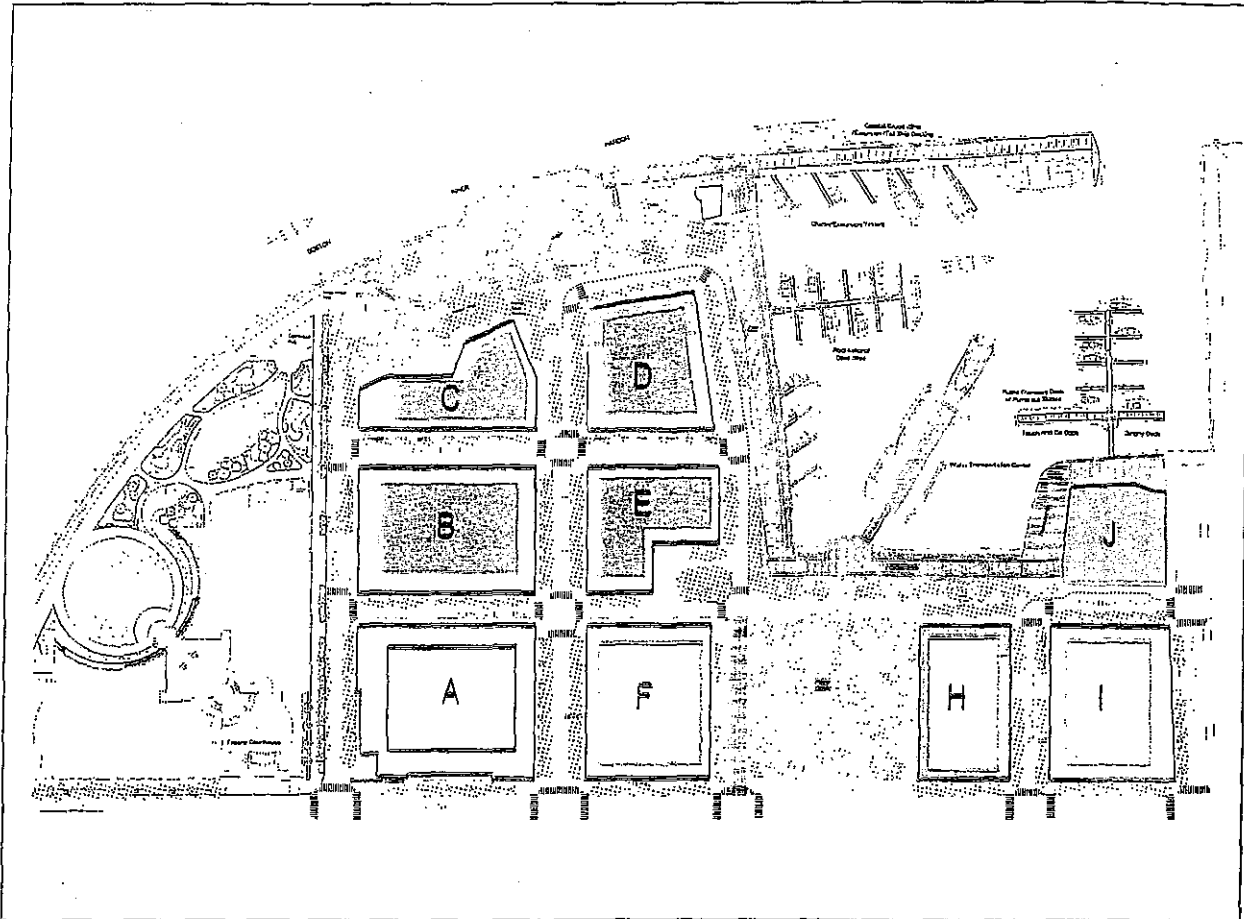

BLOCK	PROGRAM	FLOORS	HEIGHT	SF SUBTOTAL
BLOCK A	HOTEL	23	243.80'	492,475 SF
BLOCK B	RESIDENTIAL	22	238.50'	424,625 SF
BLOCK C	RESIDENTIAL	15	175.00'	225,520 SF
BLOCK D	RESIDENTIAL	15	175.00'	195,460 SF
BLOCK E	RESIDENTIAL	20	236.00'	314,025 SF
BLOCK F	OFFICE	20	237.00'	492,635 SF
BLOCK H	OFFICE	15	175.00'	290,115 SF
BLOCK I	OFFICE	19	225.50'	492,145 SF
TOTALS				2,927,000 SF
BLOCK D	CULTURAL/CIVIC			17,000 SF
BLOCK H	CULTURAL/CIVIC			30,000 SF
BLOCK J	CULTURAL/CIVIC			60,000 SF
TOTALS				3,034,000 SF
HOTEL				479,000 SF
RESIDENTIAL				1,091,200 SF
OFFICE				1,223,380 SF
RETAIL				134,420 SF
CULTURAL/CIVIC				107,000 SF
TOTALS				3,034,000 SF



Fan Pier Development

Development Program Summary

Figure 1

**EXHIBIT C**  
**PERMITTED USES**

(a) Water-Dependent Uses

Dock, slip, pier, wharf, anchorage, or moorage for Commercial Vessels and Recreational Vessels awaiting servicing, provisions, on or off loading of people or cargo at delivery;

Water-Dependent recreational facility, Recreational Marina, facilities for the use, hire or charter of Commercial vessels, Boat Rental Establishment, recreational sailing or boating school; yacht club;

Parks, esplanades, boardwalks, and other pedestrian facilities that promote public use and enjoyment of the water and are located at or near the water's edge;

Aquarium, including uses reasonably appurtenant thereto such as gift shop, laboratory space, classrooms, restaurant, and food service uses, office space, conference facilities, meeting rooms;

Other cultural, educational, research, or training facilities dedicated primarily to marine purposes, or water-oriented exhibits;

Waterborne passenger transportation facilities, such as those serving ferries, cruise ships, commuter and excursion boats, and water shuttles and taxis;

Navigation aids, marine police and fire stations, and other waterways public safety and law enforcement facilities;

Shore protection structures, such as seawalls, bulkheads, revetments, dikes, breakwaters, rip rap, wave deflectors, and the like.

(b) Open Space/Recreational Uses

Open space for active or passive recreational use or dedicated to the conservation of natural resources, including but not limited to the waterways areas, beaches, reservations, parks, public gardens, and playgrounds; nonprofit sailing center or other public recreational facility operated by a nonprofit organization; publicly accessible garden conservatory or botanical garden.

Recreational building (other than a nonprofit sailing center, other public recreational facility operated by a nonprofit organization, or publicly-

accessible garden conservatory or botanical garden) on an Open Space area that is necessary and/or appropriate to the enhanced enjoyment of the particular Open Space area and is open to the public.

(c) Community Uses and Cultural Facilities

Library, museum, gallery, concert hall, legitimate theater, auditorium, performance space, aquarium, or historical exhibit open to public generally;

Community center or community service facility;

Day care center.

(d) Residential Uses

Multifamily residential uses.

(e) Hotel Uses

Hotel, conference and meeting facilities, restaurant, lounge, bar, store primarily serving the retail needs of hotel, conference, and meeting guests, health club, swimming pool, storage and office use accessory to hotel use.

(f) Office Uses

Office of professional persons, not accessory to a main use;

Real estate, insurance, financial service institution, or other agency or government office;

Office building, post office, bank (other than drive-in bank), or similar establishment.

(g) Intentionally Omitted.

(h) Local Retail/Services Uses

Store primarily serving the local retail business or service needs of the neighborhood and harbor/waterfront users, including but not limited to chandlery, barber shop, beauty shop, shoe repair shop, self-service laundry, pick-up and delivery station of laundry or drycleaner, tailor shop, hand laundry;

Store retailing one or more of the following but not limited to: food, baked goods, groceries, drugs, tobacco products, clothing, drygoods, books, film, video, art, flowers, paint, hardware, and small household appliances.

(i) General Retail Uses

Department store, furniture store, general merchandise mart, or other store serving the general retail business needs of a major part of the city, including accessory storage.

(j) Restaurant Uses

Lunchroom, restaurant, cafeteria, or other place for the service or sale of food or drink for on-premises consumption, including outdoor cafes;

Place for sale and consumption of food and beverages (other than drive-in restaurants) providing dancing or entertainment or both;

In a structure, sale over the counter, not wholly incidental to a local retail business or restaurant use, of food or drink prepared on premises for off-premises consumption or for on-premises consumption if, as so sold, such food or drink is ready for take-out (other than drive-in restaurants).

Pushcart food vendors.

(k) Educational Uses

Marine research and/or training institute for educational institution provided that water access is required for the facility or its operation.

(l) Public Services Uses (subject to St. 1956, Chapter 665, Section 2)

Public service pumping station, public service substation, automatic telephone exchange, fire station, police station;

Flood, water level, or tidal control facility;

Cable conduit, pipeline crossing, stormwater outlet, or other similar utility structure.

(m) Transportation Uses

Public transportation facility, bus station, trolley station.

(n) Place of Worship

Place of Worship; monastery; convent; parish house.

(o) Exhibition and Conference Use

Exhibition hall, conference center, meeting facilities, auditorium.

(p) Art Uses/Artists' Mixed Use

(q) Intentionally Omitted.

(r) Accessory and Ancillary Uses

Any of the following uses accessory or ancillary to an allowed use, subject to the limitations and restrictions of Article 10:

- (i) any use accessory or ancillary to, and ordinarily incident to, a lawful main use; provided that such use is not specifically forbidden in the district; and provided further that any such use shall be subject to the same restrictions, conditions, limitations, provisos and safeguards as the use to which it is accessory;
- (ii) an office, within a main building, of an accountant, architect, attorney, dentist, physician, or other professional person who resides in such building;
- (iii) an occupation for profit customarily carried on in a dwelling unit by a person residing therein provided that such occupation is carried on in a main building and requires only equipment ordinarily incident to a dwelling unit and that no nonresident help is employed and that there is no trading in merchandise;
- (iv) the keeping of marine life or laboratory animals incidental to a lawful educational, research center, aquarium, or institutional use;
- (v) as accessory uses to hotel uses, restaurants, conference facilities, retail and service establishments serving guests and visitors and other uses incidental to the operation of a hotel;
- (vi) Intentionally Omitted;
- (vii) the storage of flammable liquids and gases incidental to a lawful use;



(viii) permanent dwellings for personnel required to be resident on a Lot for the safe and proper operation of a lawful main use;

(ix) day care center;

(x) health club facility, tennis court, swimming pool.

(5) Accessory Parking Uses

Parking garage or on-street parking.

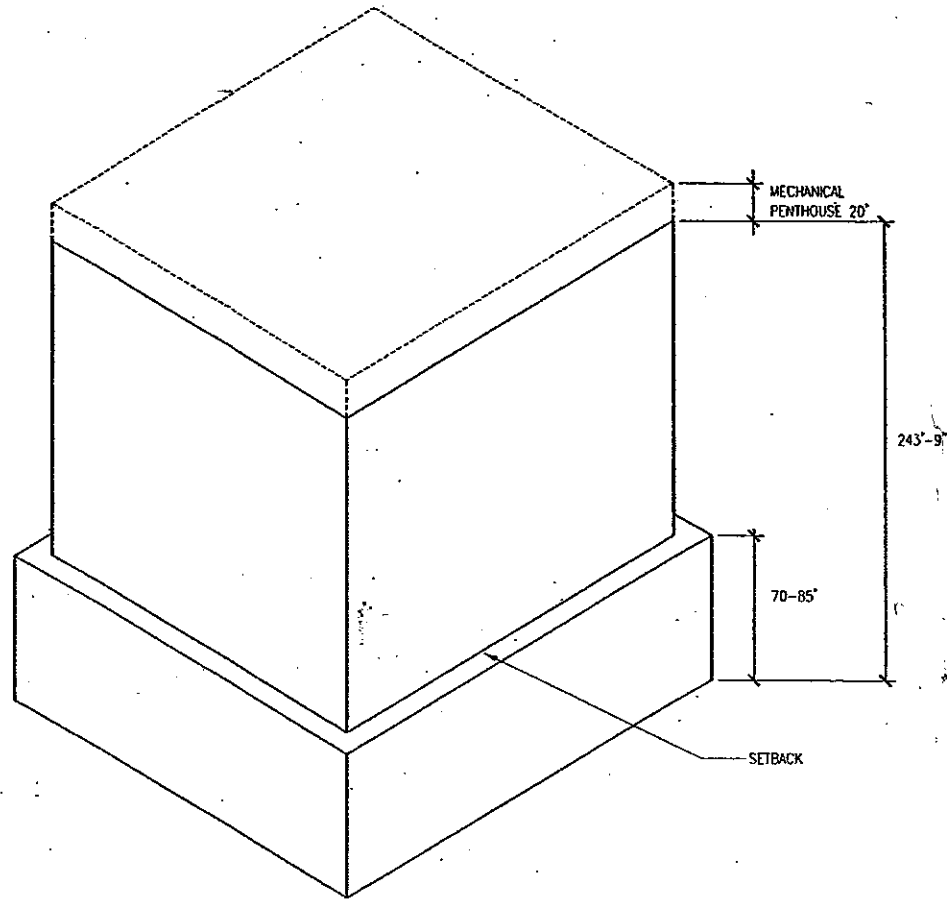

MASSING ENVELOPE

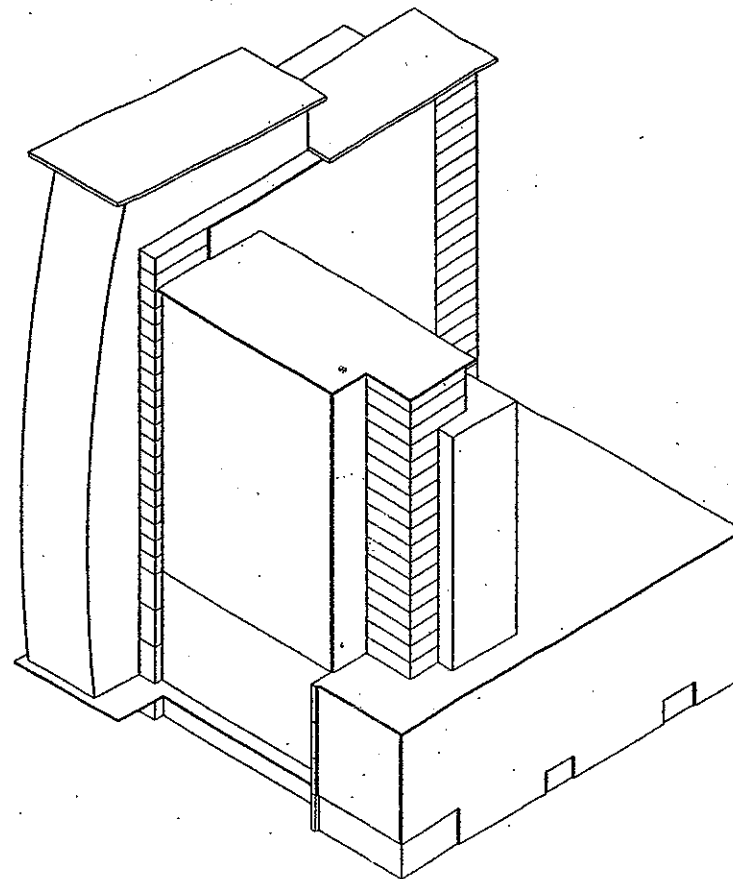

SAMPLE BUILDING MASSING

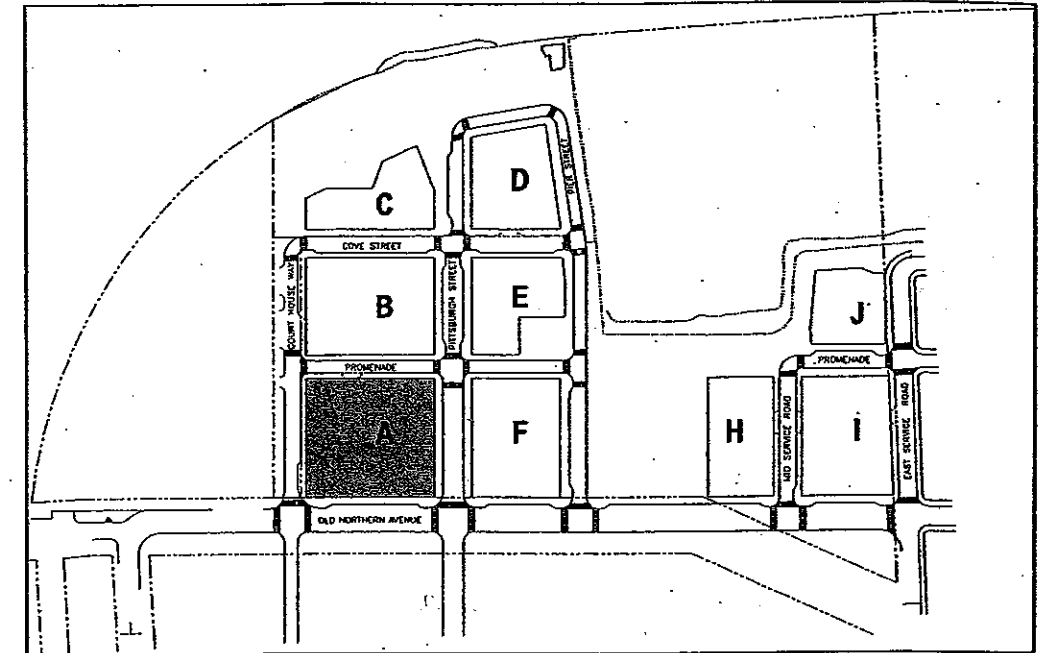

KEY PLAN

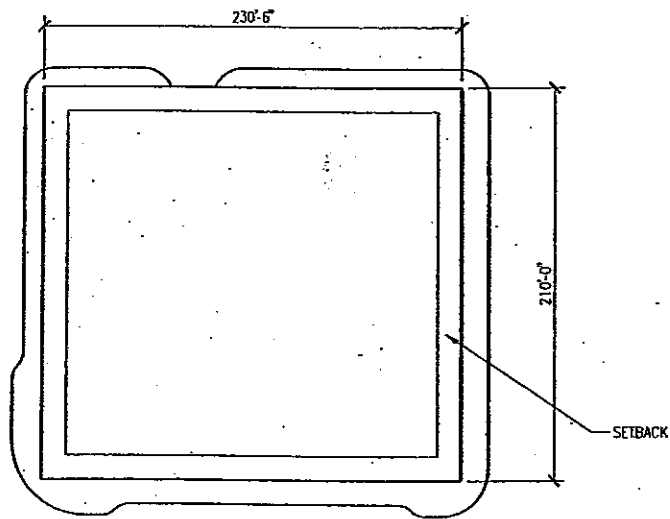

MASSING ENVELOPE  
ROOF PLAN

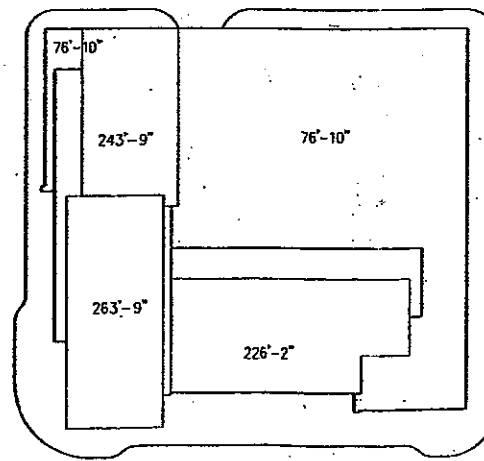

SAMPLE BUILDING MASSING  
ROOF PLAN



Fan Pier Development

Design Guideline: Building A

Figure 2

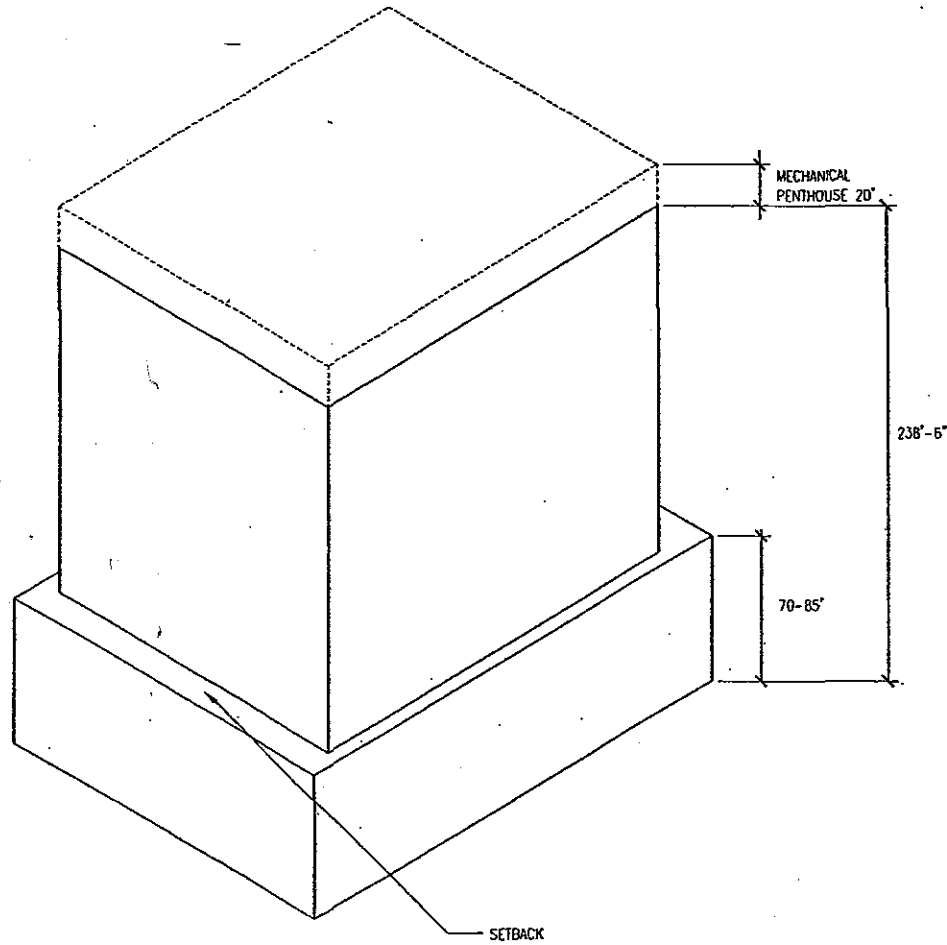

MASSING ENVELOPE

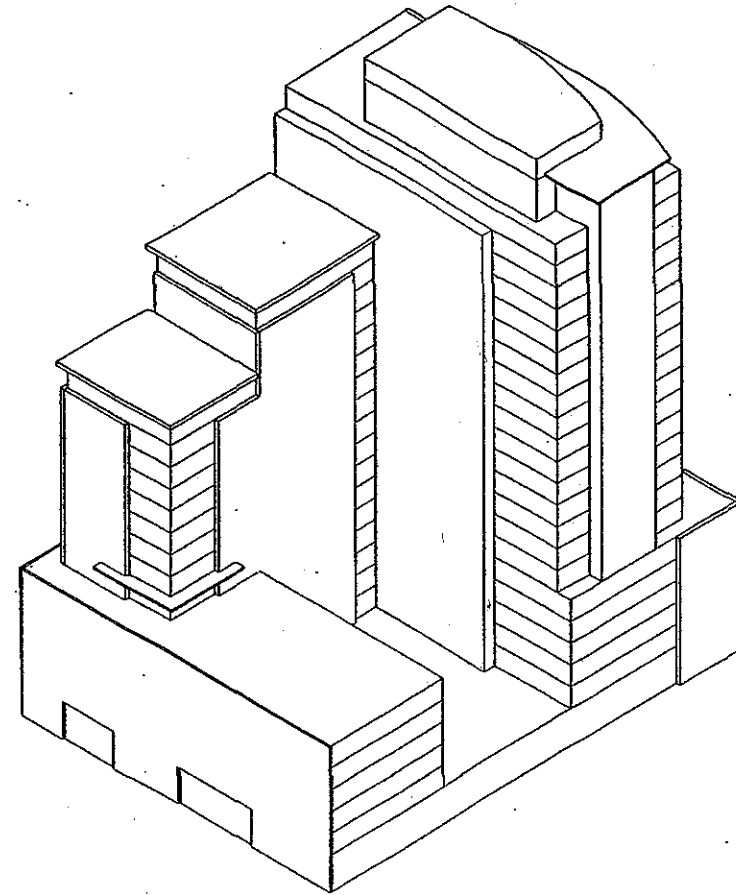

SAMPLE BUILDING MASSING

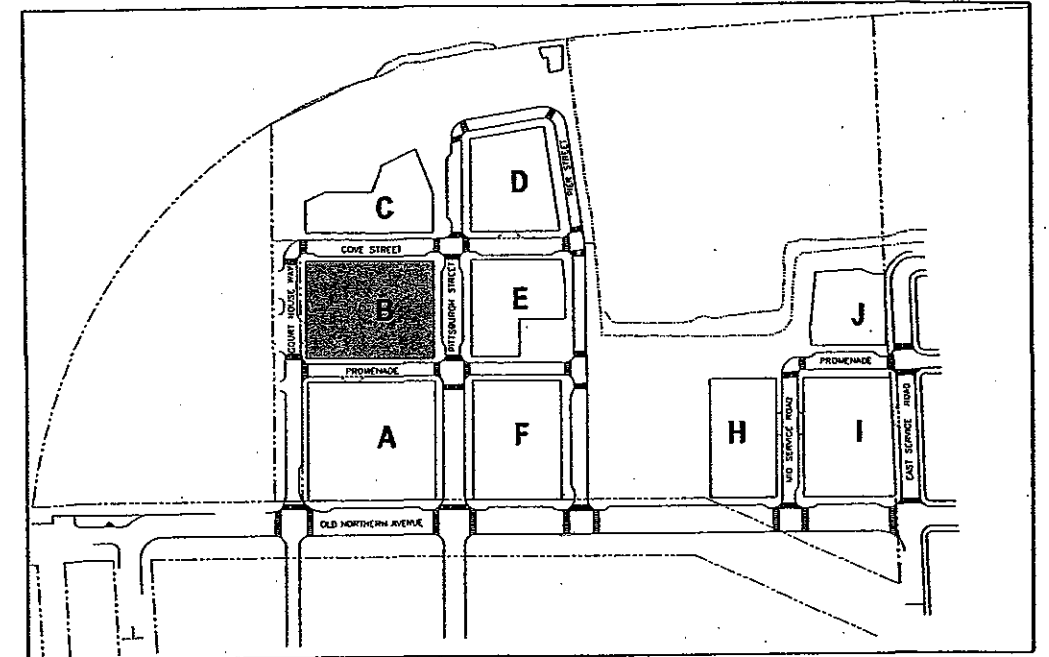

KEY PLAN

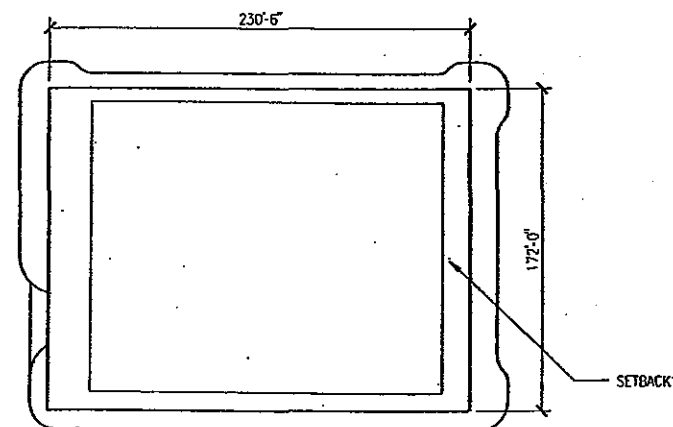

MASSING ENVELOPE  
ROOF PLAN

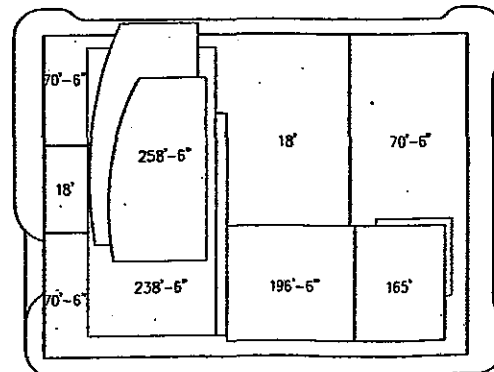

SAMPLE BUILDING MASSING  
ROOF PLAN



Fan Pier Development

Design Guideline: Building B

Figure 3

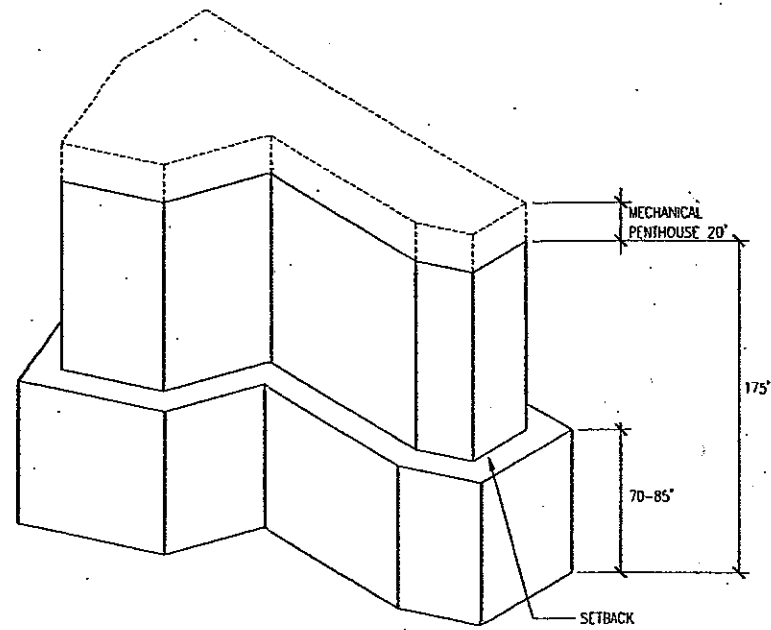

MASSING ENVELOPE

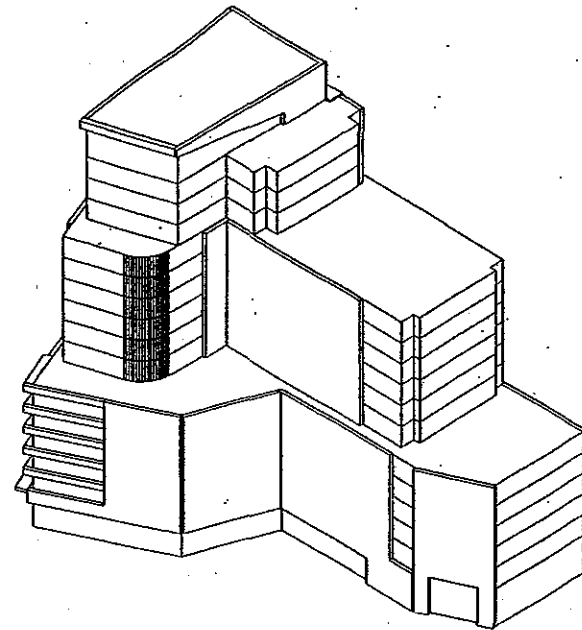

SAMPLE BUILDING MASSING

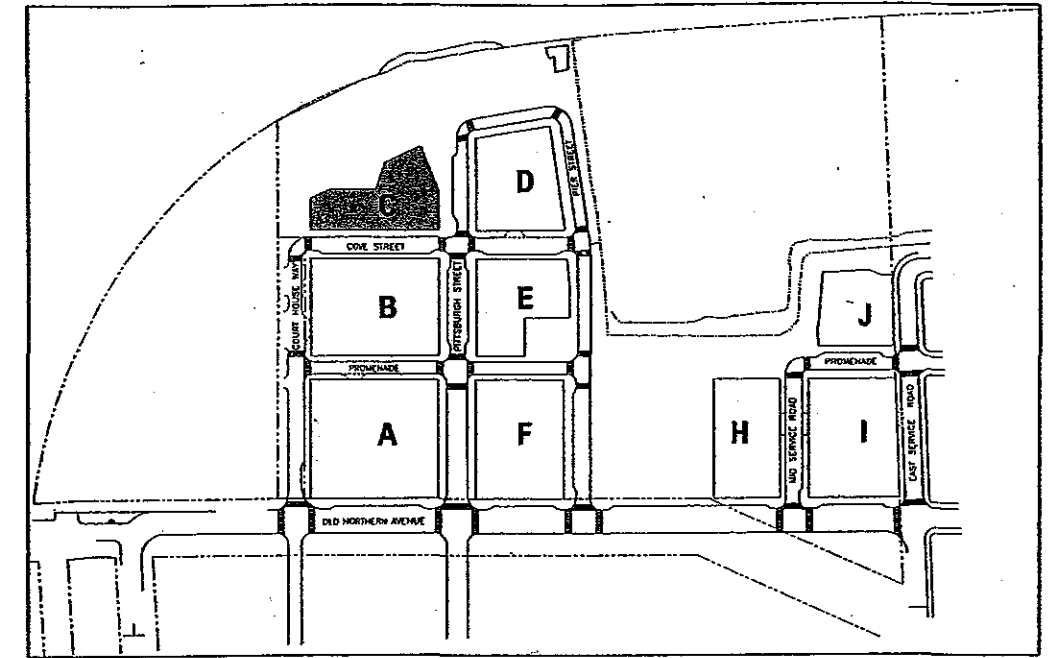

KEY PLAN

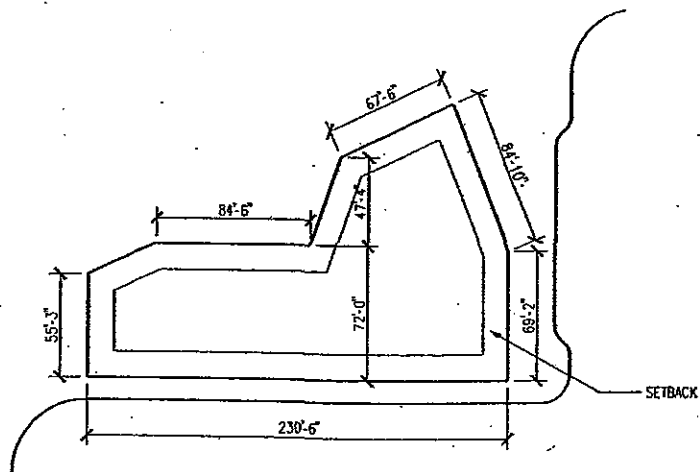

MASSING ENVELOPE  
ROOF PLAN

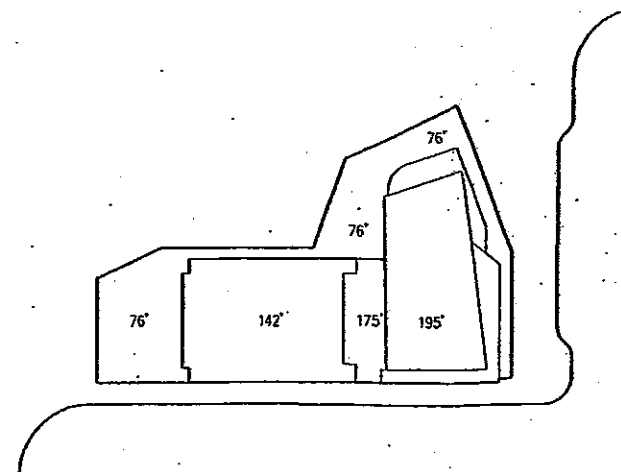

SAMPLE BUILDING MASSING  
ROOF PLAN



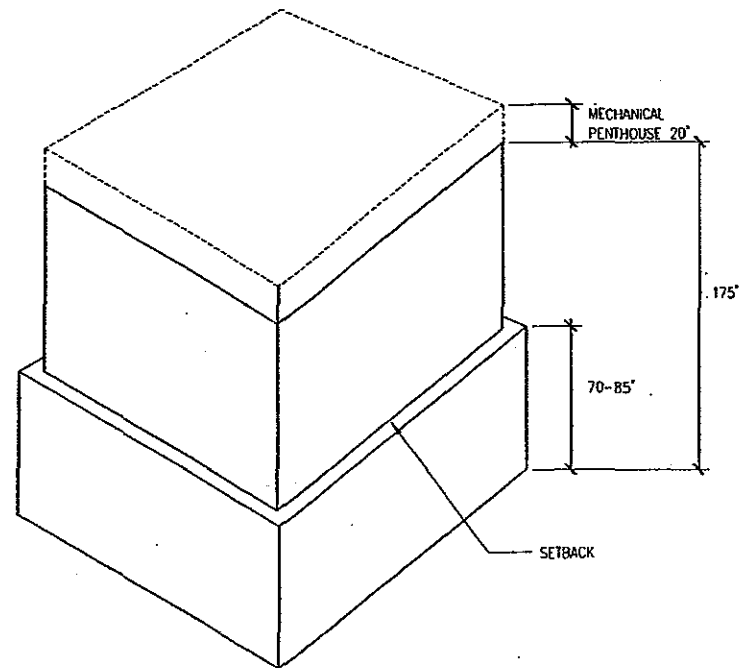

MASSING ENVELOPE

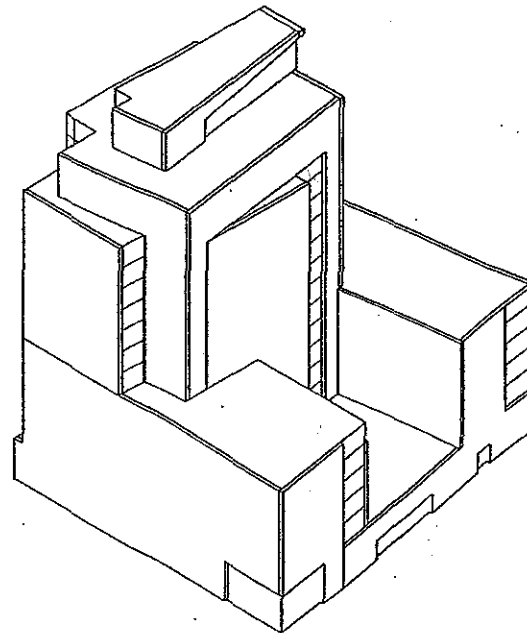

SAMPLE BUILDING MASSING

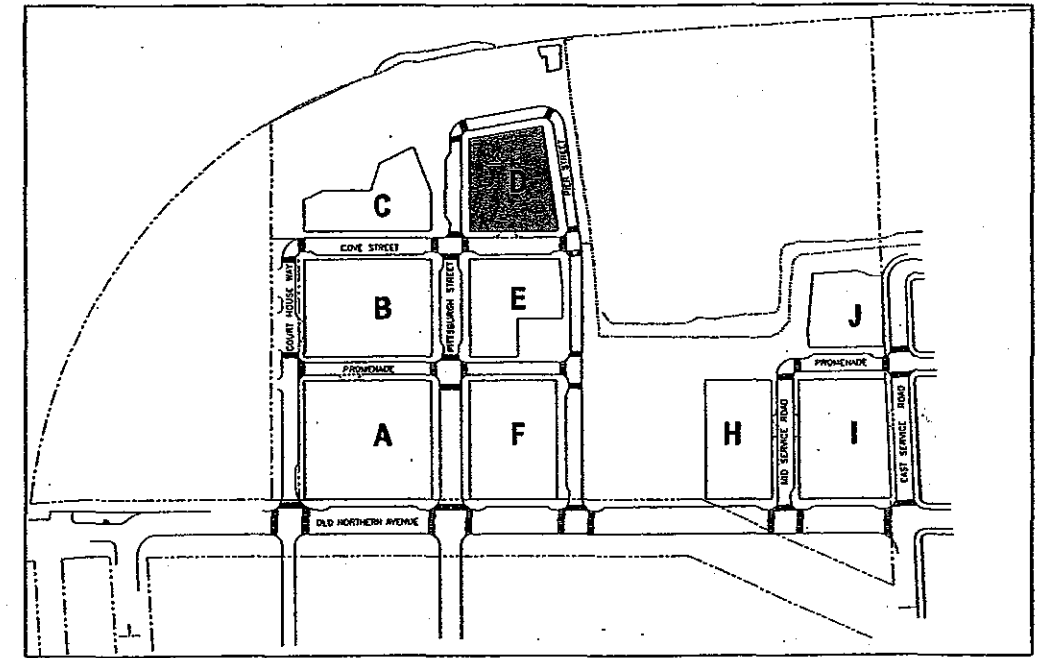

KEY PLAN

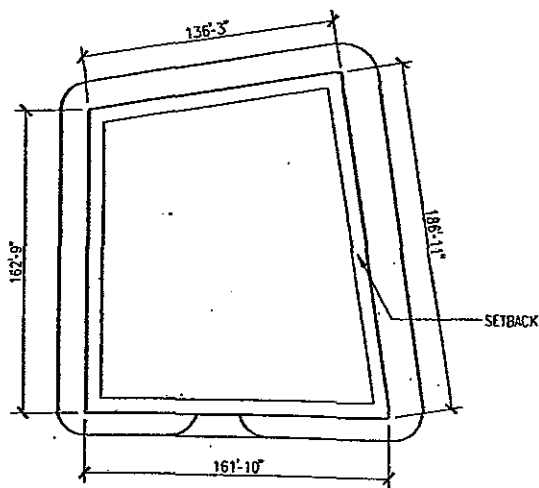

MASSING ENVELOPE  
ROOF PLAN

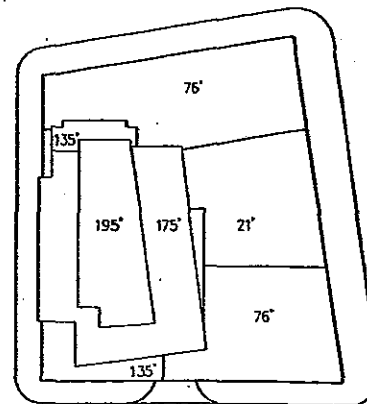

SAMPLE BUILDING MASSING  
ROOF PLAN



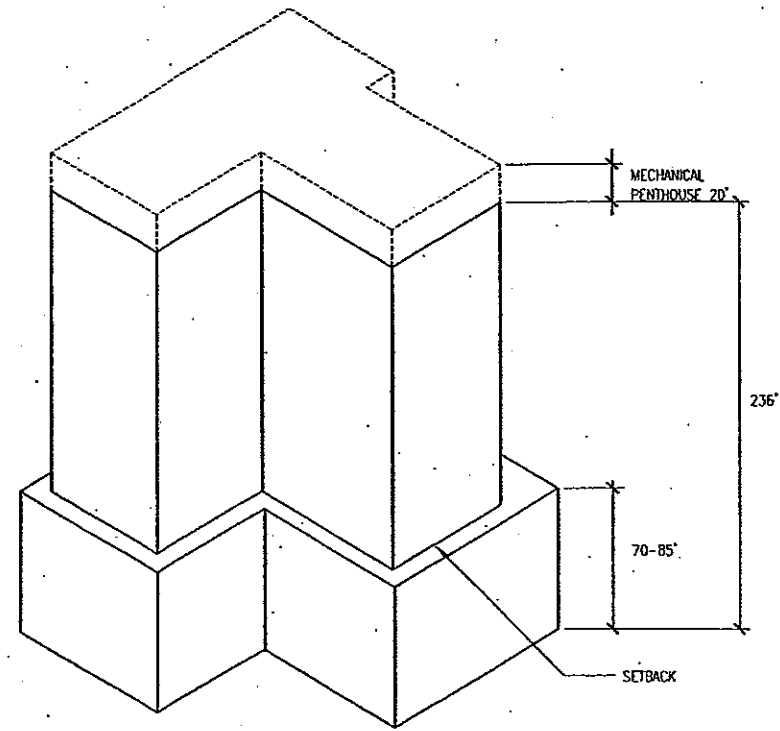

MASSING ENVELOPE

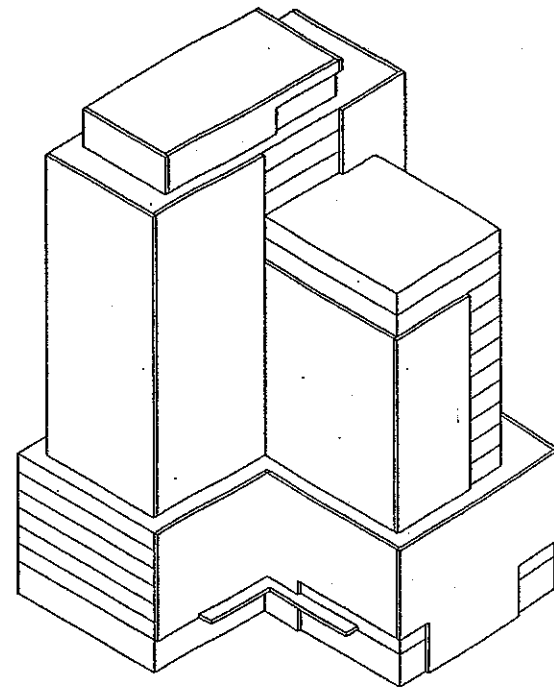

SAMPLE BUILDING MASSING

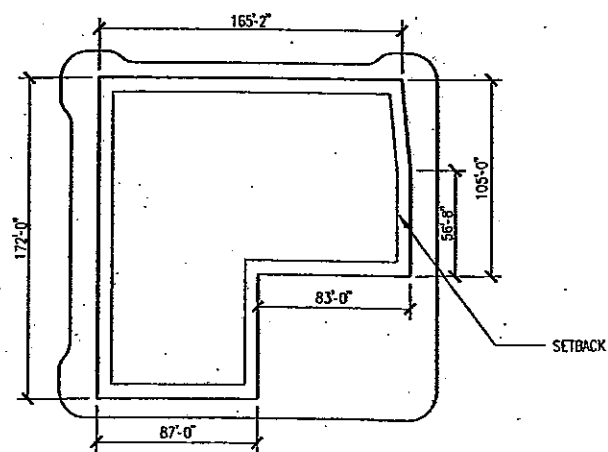
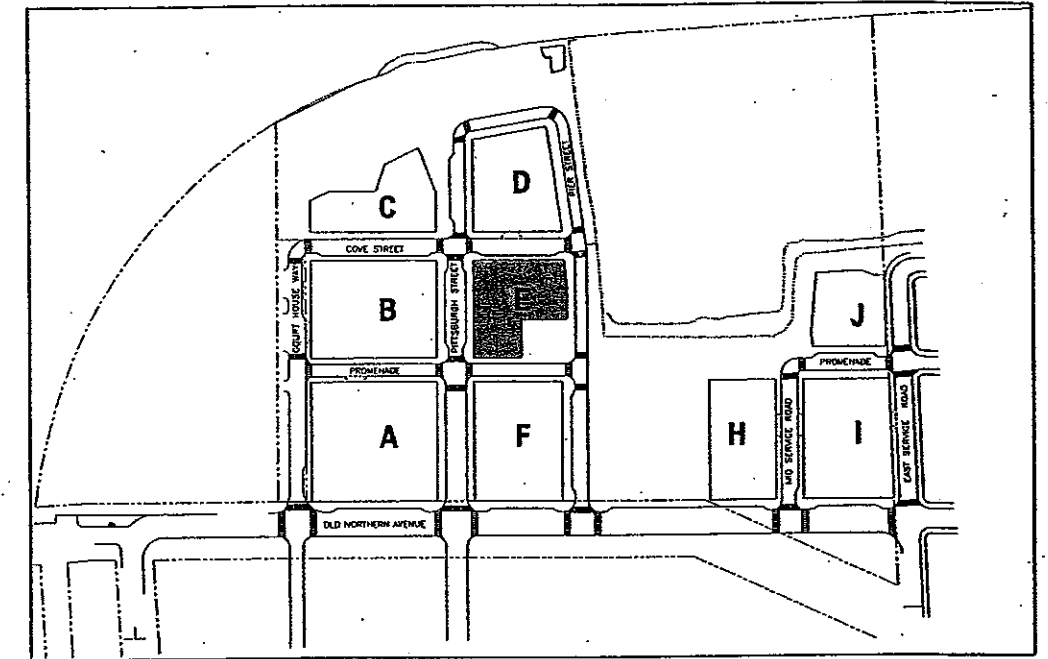

MASSING ENVELOPE  
ROOF PLAN

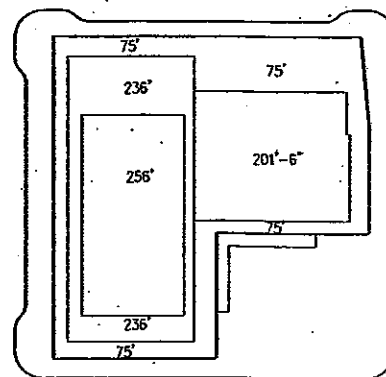

SAMPLE BUILDING MASSING  
ROOF PLAN



Fan Pier Development

Design Guideline: Building E

Figure 6

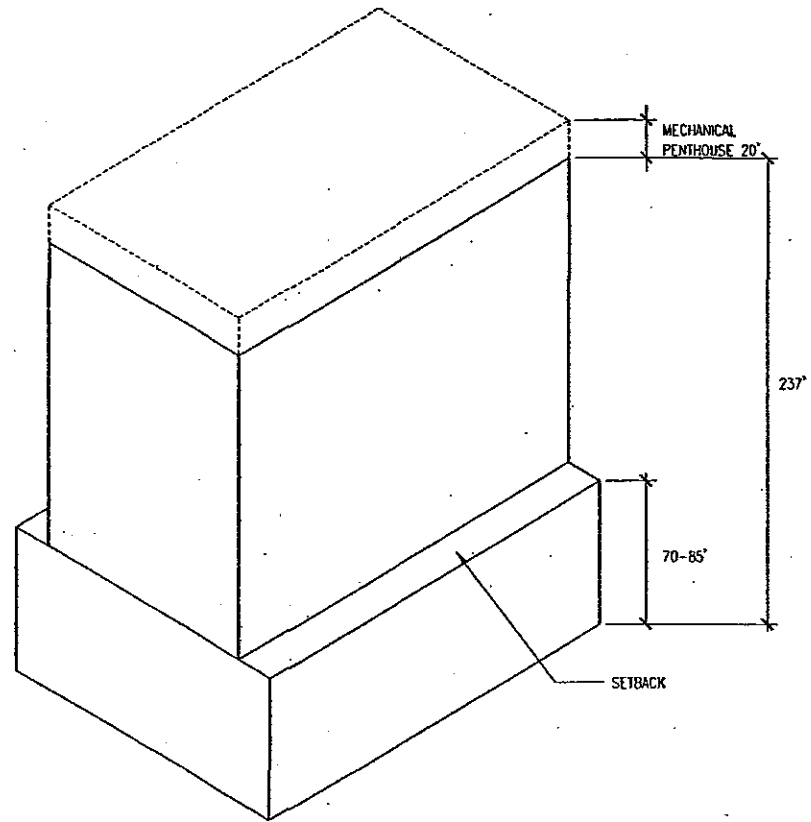

MASSING ENVELOPE

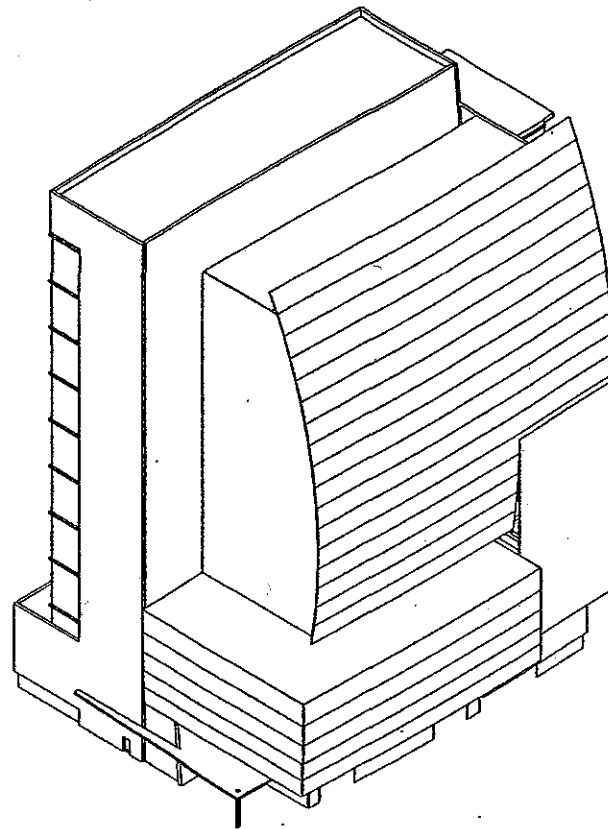

SAMPLE BUILDING MASSING

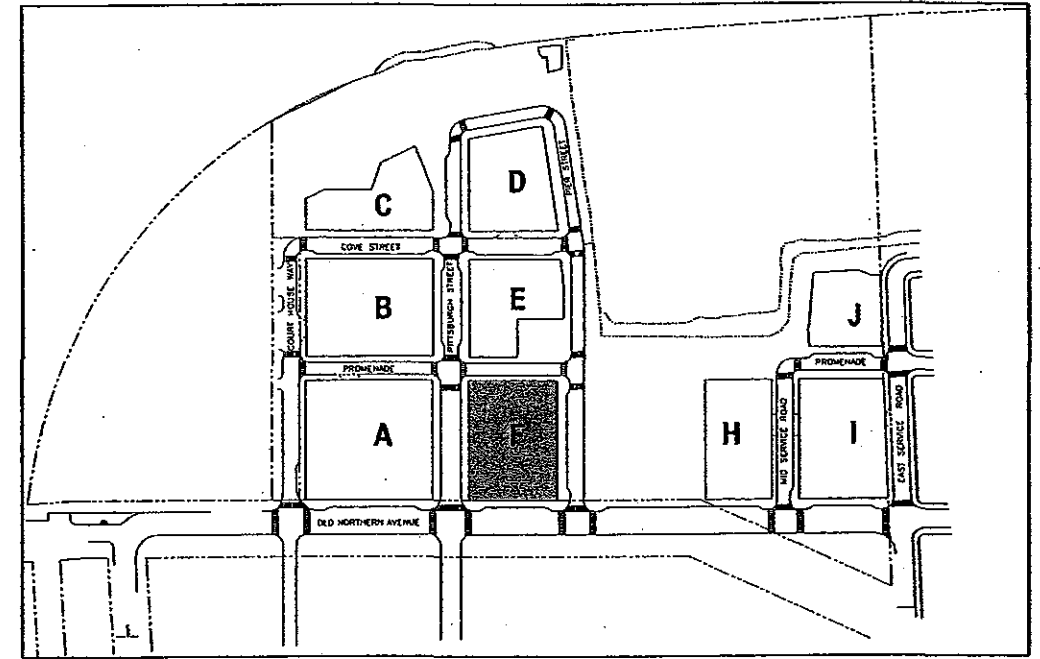

KEY PLAN

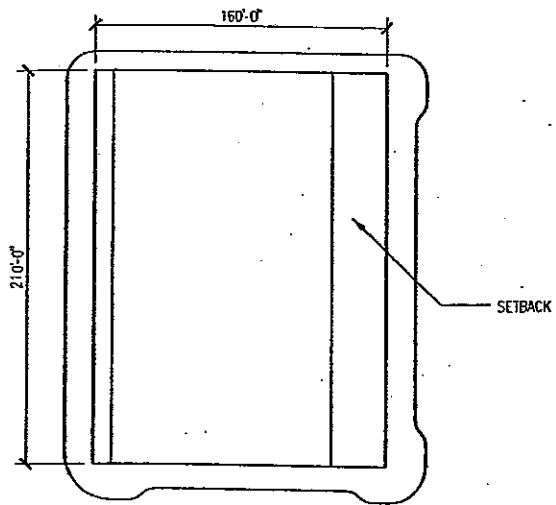

MASSING ENVELOPE  
ROOF PLAN

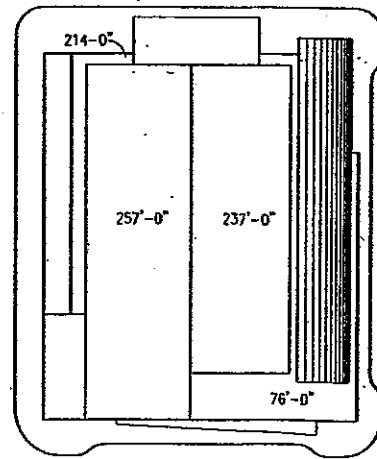

SAMPLE BUILDING MASSING  
ROOF PLAN



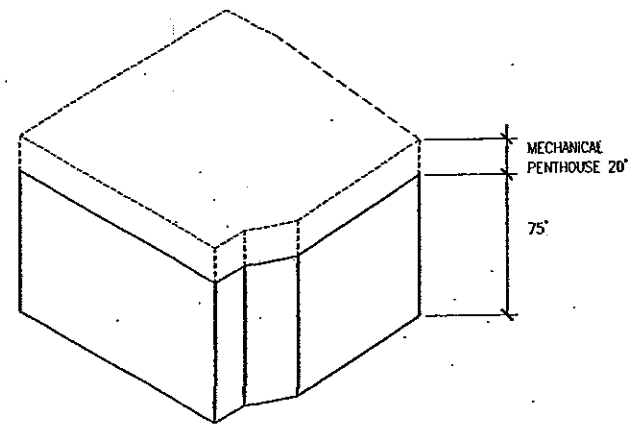

MASSING ENVELOPE

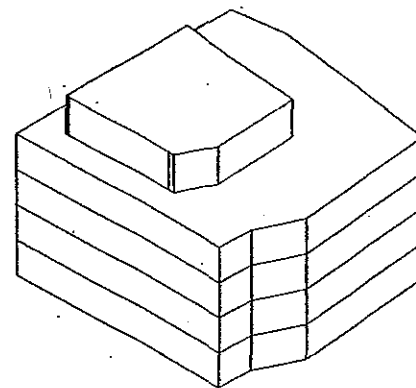

SAMPLE BUILDING MASSING

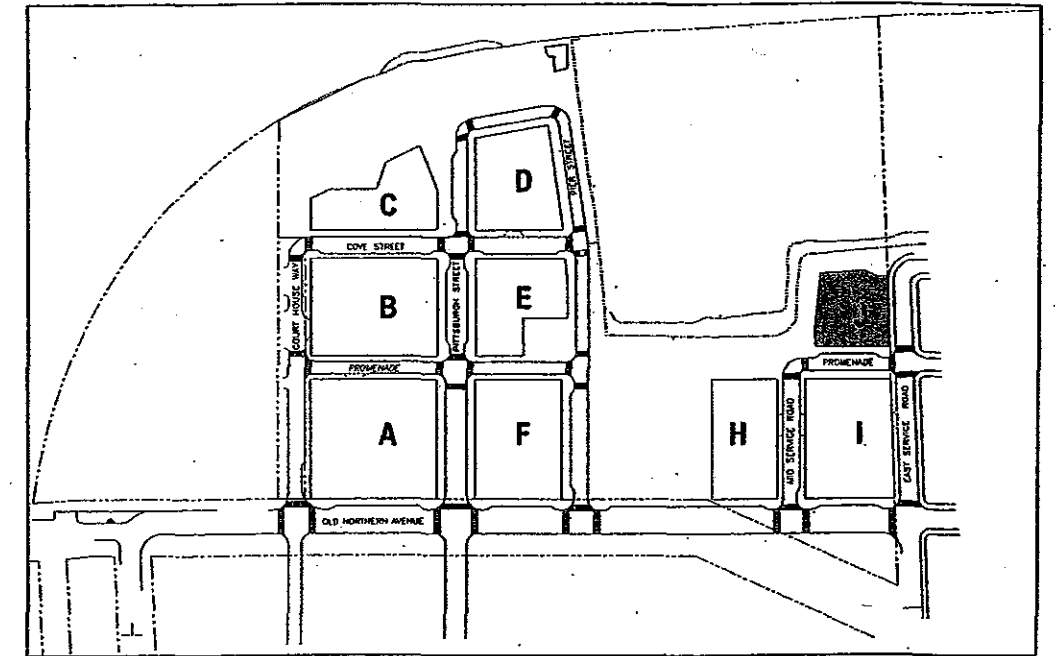

KEY PLAN

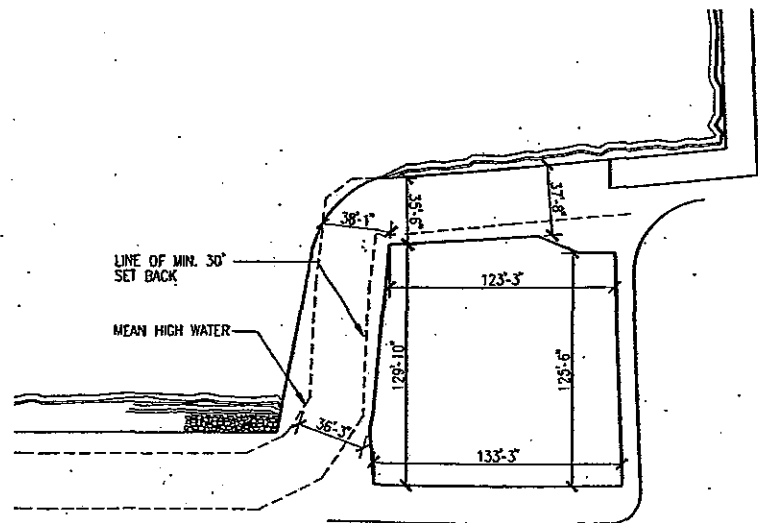

MASSING ENVELOPE  
ROOF PLAN

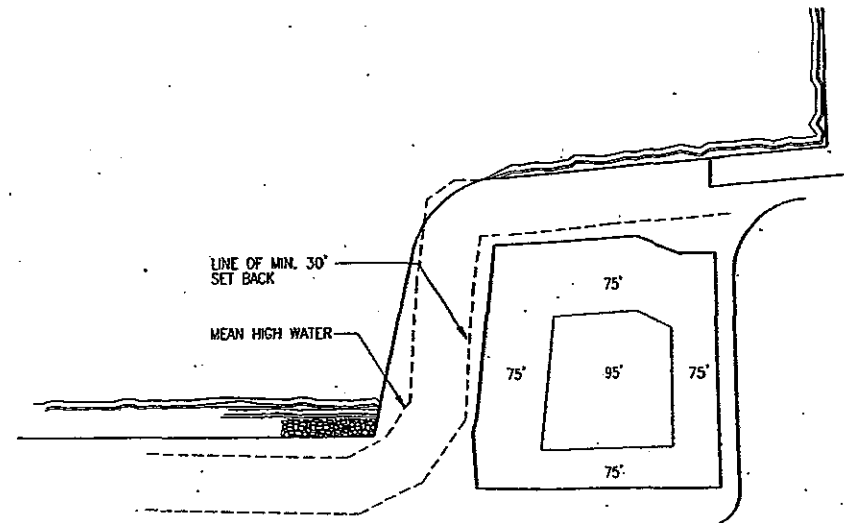

SAMPLE BUILDING MASSING  
ROOF PLAN





**MEMORANDUM****NOVEMBER 14, 2001**

**TO:** BOSTON REDEVELOPMENT AUTHORITY AND  
MARK MALONEY, DIRECTOR

**FROM:** KATHERINE KOTTARIDIS, DIRECTOR OF ECONOMIC DEVELOPMENT  
LINDA HAAR, DIRECTOR OF PLANNING AND DEVELOPMENT  
HOMER RUSSELL, DIRECTOR OF URBAN DESIGN  
JOHN O'BRIEN, SENIOR PROJECT MANAGER

**SUBJECT:** THE FAN PIER DEVELOPMENT - PUBLIC HEARINGS IN CONNECTION  
WITH A PLANNED DEVELOPMENT AREA DEVELOPMENT PLAN UNDER  
ARTICLE 80C AND A DEVELOPMENT IMPACT PROJECT UNDER ARTICLE  
80B.

---

**SUMMARY:** This memorandum requests that the Boston Redevelopment Authority (the "Authority") approve the Planned Development Area Development Plan for the Fan Pier Development (the "Fan Pier PDA Development Plan"), pursuant to Section 80C of the Boston Zoning Code (the "Code"), and authorize the Director to: (1) issue an Adequacy Determination relating to the Fan Pier Final Project Impact Report ("Fan Pier FPIR"); (2) petition the Boston Zoning Commission (the "Zoning Commission") for approval of Planned Development Area designation for the parcel of land which is the subject of the Fan Pier PDA Development Plan pursuant to Section 80C-5 of the Code; (3) petition the Zoning Commission for approval of the Fan Pier PDA Development Plan pursuant to Section 80C-5 of the Code; (4) submit a Section 18 Recommendation to the Department of Environmental Protection; (5) issue a Certification of Consistency pursuant to Section 80C-8 of the Code upon completion of the Article 80 review process; (6) issue a Certification of Compliance under Large Project Review pursuant to Section 80B-6 of the Code upon completion of the Article 80 review process; and (7) execute and deliver all documents deemed appropriate by the Director in connection with the Fan Pier Development pursuant to Article 80, including, without limitation, a Cooperation Agreement, Development Impact Project Agreement, Boston Residents Construction Plan, First Source Agreement and Memorandum of Understanding, Transportation Access Plan Agreement and Construction Management Plan.

---

**FAN PIER PDA DEVELOPMENT PLAN DESCRIPTION:**

The Fan Pier Land Company, a Delaware corporation (the "Proponent") is the owner of the approximately 20.9 acre site located at 28-52 Northern Avenue in Boston, Suffolk County, Massachusetts (the "Site"). The Site abuts the Boston Inner Harbor to the north, the Moakley Federal Courthouse to the west, Northern Avenue to the south, and Pier 4 to the east. The Site is currently vacant and is used as a surface parking facility. The Proponent has submitted a PDA Development Plan to the Authority which contemplates the construction of nine (9) new buildings, containing 2,927,000 square feet of residential, office, hotel and retail space as well as 107,000 square feet dedicated to civic uses, marina use and associated parking (collectively, the "Fan Pier Development").

allocated to individual buildings in accordance with their respective square footage, with the 100,000 square foot exemption being applied to the first building for which a building permit is issued. Subject to approval of the Neighborhood Housing Trust and the Boston Redevelopment Authority, the Developer may elect to make such contribution by utilizing the Housing Creation Option.

Jobs Contribution. As required under Section 80B-7(3)(b) of the Boston Zoning Code, the Development will also be responsible for contributing a Jobs Contribution Exaction with regard to the project. The Jobs Contribution Exaction shall be payable at the times, in the manner and under the conditions specified in the DIP Agreement. It is anticipated that the total Jobs Contribution Exaction will equal \$1,892,022, calculated on the basis of 1,835,800 square feet of commercial development (less a one-time 100,000 square foot exemption) times a contribution rate of \$1.09 for each square foot of development.

Affordable Housing. The Fan Pier Development will create on-site and off-site affordable housing units within the South Boston Waterfront equaling 20% of the total number of market rate units to be built at Fan Pier. The Proponent will dedicate fifty (50) of the rental housing units to be constructed on Fan Pier to low and moderate income persons or families earning between 80% and 120% of Boston's median income. The Proponent will also construct or cause to be constructed an additional seventy-five (75) housing units off-site, which will also be affordable to low and moderate income persons or families earning between 80% and 120% of Boston's median income. The above equates to a total of 125 on and off-site affordable units, or 20% of the 625 proposed market rate units to be constructed at Fan Pier. To memorialize the aforementioned affordable housing commitments and to fulfill the requirements of Article 80, the Authority and the Proponent will enter into a Cooperation Agreement and Affordable Housing Agreement.

#### MUNICIPAL HARBOR PLAN:

Pursuant to 301 CMR 23.00 et seq., a Municipal Harbor Plan ("MHP") for the South Boston Waterfront was submitted to the Secretary of Environmental Affairs by the Authority in July 2000. On December 6, 2000, the Secretary of Environmental Affairs approved the South Boston Waterfront MHP with conditions. The Fan Pier Development lies within the area governed by the South Boston Waterfront MHP. In order to ensure that the Fan Pier Development will be in compliance with the terms and conditions of the South Boston Waterfront MHP, as approved, the MHP requires that permanent zoning for the site be consistent with the MHP. In this regard, such permanent zoning comes in the form of a Planned Development Area and associated Development Plans. In addition, the Fan Pier Development will also be governed by the terms and conditions of a Chapter 91 waterways license and a Transportation Access Plan Agreement, both of which will contain enforceable commitments in furtherance of the MHP terms and conditions.

#### FAN PIER DEVELOPMENT REVIEW:

The Fan Pier Development is subject to Large Project Review under Section 80B of Article 80 of the Code. On April 18, 2000, the Proponent submitted a Draft Project Impact Report for the Fan Pier Development. The Fan Pier Development was thereafter revised to comply with the Municipal Harbor Plan as approved by the

Secretary of Environmental Affairs and to reflect the numerous public comments and dialogue that took place. On August 3, 2001, the Proponent submitted the Final Project Impact Report ("FPIR"). The public comment period for the FPIR ended on October 17, 2001. As a Development Impact Project under Article 80, Section 80B-7, the Fan Pier Development is subject to a hearing before the BRA Board of Directors in accordance with Article 80, Section 80B-5.

#### FAN PIER PDA DEVELOPMENT PLAN:

The Fan Pier PDA Development Plan is subject to review under Section 80C of Article 80 of the Code. On August 3, 2001, the Proponent submitted the Fan Pier PDA Development Plan. The public comment period for the Fan Pier PDA Development Plan ended on September 14, 2001. As a PDA project under Article 80, Section 80C, the Fan Pier Development is also subject to a hearing before the BRA Board of Directors in accordance with Article 80, Section 80B-5.

The Fan Pier PDA Development Plan adequately describes the following project elements:

- Size, including gross floor area, building height, and FAR;
- Uses; and
- Location, including the location of each proposed building and use.

Final plans and specifications (i.e., contract documents) for any portion of the Development shall be subject to review and approval by the Authority in accordance with its Development Review Procedures (1985, rev. 1986). The final plans and specifications, as approved by the Authority, shall be deemed to be consistent with the Fan Pier PDA Development Plan and to have addressed all design requirements set forth in Section 27P-14 of the Code.

#### BOSTON CIVIC DESIGN COMMISSION REVIEW:

The Fan Pier Development comes under the jurisdiction of the Boston Civic Design Commission (the "BCDC") pursuant to Article 28 of the Code. At its meeting of October 2, 2001 the BCDC voted a recommendation of approval of the Fan Pier PDA Development Plan. Forthcoming schematic and design development plans must be reviewed by the BCDC and approved by the Authority.

#### OTHER PUBLIC BENEFITS:

Taxes. Upon completion of full build, the Fan Pier Development will contribute an estimated \$15 to \$20 million per year in property taxes, in comparison with current real estate taxes on the property of \$250,000.

Jobs. Construction of the Fan Pier Development will create an estimated 1,750 union construction jobs. A Boston Residents Construction Plan ("BRCP") will be submitted in accordance with the Boston Jobs Policy. Under the BRCP the Proponent will make good-faith efforts to ensure that Boston residents work at least 50% of the total employee hours, minorities work at least 25% of the total employee hours, and women work at least 10% of the total employee hours. The Fan Pier Development's hotel component alone will create approximately 550 jobs for workers with diverse skills and educational backgrounds. The companies leasing space in the office buildings

will create a significant number of professional and support jobs. The Proponent will enter into a First Source Agreement and Memorandum of Understanding outlining good-faith efforts to ensure that 50% of the permanent employees in the Fan Pier Development are Boston residents.

Daycare Facilities. On-site space will be set aside for daycare facilities, in compliance with City of Boston requirements.

Public Amenities. The Fan Pier Development will include major new public amenities for the South Boston Waterfront District, including two waterfront parks, new facilities for water transportation and recreation, an extensive addition to Harborwalk and new civic and cultural facilities, all as described above.

Infrastructure Improvements. Construction of the Fan Pier Development will include new streets and sidewalks, along with improvements to utility and stormwater discharge systems.

#### FINDINGS:

The foregoing description of the Fan Pier Development and its associated public benefits support the following findings:

The Fan Pier PDA Development Plan; (a) is in a location in which Planned Development Areas are permitted by the Code, (b) complies with provisions of underlying zoning that establish use, dimensional design or other requirements for a planned development area; (c) complies with any provisions of underlying zoning that establish planning and development criteria, including public benefits, for planned development areas; (d) conforms to the plan for the district, subdistrict, or similar geographic area in which the Fan Pier PDA Development Plan is located, and to the general plan for the City as a whole; and (e) on balance, nothing in the Fan Pier PDA Development Plan will be injurious to the neighborhood or otherwise detrimental to the public welfare, weighing all the benefits and burdens; and further

The public benefits plan of the Fan Pier PDA Development Plan are consistent with the goals of the South Boston Waterfront Master Plan Interim Report and Seaport Public Realm Plan, including (a) the creation of new permanent jobs; (b) the creation of new community housing opportunities; and (c) the enhancement of the public realm, including the provision of waterfront public facilities and substantial additions to the Harborwalk, the provision of accessible public open space, and the activation of the water sheet; and further,

The Fan Pier PDA Development Plan is in substantial conformance with the provisions of the Waterfront District in South Boston Master Plan and the Municipal Harbor Plan; and further,

The Fan Pier FPIR satisfies all requirements set forth in the Preliminary Adequacy Determination; and further

The Fan Pier Development, as described in the Fan Pier FPIR, conforms to the general plan for the City as a whole and that nothing in the Fan Pier Development Plan will be injurious to the neighborhood or otherwise detrimental to the public welfare.

RECOMMENDATION:

The Fan Pier PDA Development Plan represents a beneficial waterfront site, at a scale and density appropriate for the Site and balance will be beneficial to the public welfare. The Fan Pier Development described in the FPIR conforms to the general plan for the City demonstrates that nothing in the Fan Pier Development Plan will be neighborhood or otherwise detrimental to the public welfare. In public benefits from the Fan Pier Development as described in the Development Plan and the Fan Pier FPIR, it is recommended that the Authority approve the Fan Pier PDA Development Plan pursuant to Article 80 of the Code and authorize the Director to: (1) issue an Adequacy Report for the Fan Pier FPIR pursuant to Section 80B-5 of the Code; (2) petition the Commission of the City of Boston for approval of the Fan Pier Development Plan pursuant to Section 80C-6 of the Code; (3) submit to the Department of Environmental Protection of the Commonwealth of Massachusetts a "Section 18" written recommendation; (4) issue a Certification of Compliance pursuant to Section 80C-8 of the Code upon completion of the review process; (5) issue a Certification of Compliance under Large Project pursuant to Section 80B-6 of the Code upon completion of the Article 80 process; execute and deliver all documents deemed appropriate by the Director with the Fan Pier Development pursuant to Article 80, including the Cooperation Agreement, Development Impact Project Agreement, Construction Plan, First Source Agreement and Memorandum of Understanding, Transportation Access Plan Agreement and Construction Management Plan.

Appropriate votes follow:

VOTED: That the foregoing Memorandum, including without limitation all exhibits therein, is hereby incorporated herein by this reference and made a part of the Authority.

VOTED: That after a public hearing duly held at the offices of the Authority, 2001 and after consideration of evidence presented at, and in connection with the hearing, the Authority hereby adopts the findings set forth above, with the limitation those under the section entitled "Findings".

VOTED: The Authority hereby approves the Fan Pier PDA Development Plan pursuant to Section 80C of the Boston Zoning Code.

VOTED: That the Director be, and hereby is, authorized to petition the Commission of the City of Boston for approval of the Fan Pier PDA Development Plan and the establishment of a Planned Development District for the Fan Pier PDA Development and the establishment of a Planned Development District which such Fan Pier PDA Development Plan for the Fan Pier PDA Development apply, pursuant to Section 80C-5 of the Code.

VOTED: That the Director be, and hereby is, authorized to issue an Adequacy Report for the Fan Pier Development Final Project Impact Report pursuant to Section 80B-5 of the Code.

RECOMMENDATION:

The Fan Pier PDA Development Plan represents a beneficial development of a vacant waterfront site, at a scale and density appropriate for the Site and location, which on balance will be beneficial to the public welfare. The Fan Pier Development, as described in the FPIR conforms to the general plan for the City as a whole and demonstrates that nothing in the Fan Pier Development Plan will be injurious to the neighborhood or otherwise detrimental to the public welfare. In light of the substantial public benefits from the Fan Pier Development as described in the Fan Pier PDA Development Plan and the Fan Pier FPIR, it is recommended that the Authority approve the Fan Pier PDA Development Plan pursuant to Article 80, Section 80C of the Code and authorize the Director to: (1) issue an Adequacy Determination for the Fan Pier FPIR pursuant to Section 80B-5 of the Code; (2) petition the Zoning Commission of the City of Boston for approval of the Fan Pier PDA Development Plan pursuant to Section 80C-6 of the Code; (3) submit to the Department of Environmental Protection of the Commonwealth of Massachusetts a so-called "Section 18" written recommendation; (4) issue a Certification of Consistency pursuant to Section 80C-8 of the Code upon completion of the Article 80 review process; (5) issue a Certification of Compliance under Large Project Review pursuant to Section 80B-6 of the Code upon completion of the Article 80 review process; (6) execute and deliver all documents deemed appropriate by the Director in connection with the Fan Pier Development pursuant to Article 80, including, without limitation, a Cooperation Agreement, Development Impact Project Agreement, Boston Residents Construction Plan, First Source Agreement and Memorandum of Understanding, Transportation Access Plan Agreement and Construction Management Plan.

Appropriate votes follow:

VOTED: That the foregoing Memorandum, including without limitation all terms defined therein, is hereby incorporated herein by this reference and made a finding of the Authority.

VOTED: That after a public hearing duly held at the offices of the Authority on November 14, 2001 and after consideration of evidence presented at, and in connection with, the hearing, the Authority hereby adopts the findings set forth above, including without limitation those under the section entitled "Findings".

VOTED: The Authority hereby approves the Fan Pier PDA Development Plan for the Fan Pier Development pursuant to Section 80C of the Boston Zoning Code (the "Code").

VOTED: That the Director be, and hereby is, authorized to petition the Zoning Commission of the City of Boston for approval of the Fan Pier PDA Development Plan for the Fan Pier Development and the establishment of a Planned Development Area within which such Fan Pier PDA Development Plan for the Fan Pier Development shall apply, pursuant to Section 80C-5 of the Code.

VOTED: That the Director be, and hereby is, authorized to issue an Adequacy Determination for the Fan Pier Development Final Project Impact Report pursuant to Article 80, Section 80B-5 of the Code.

VOTED: That the Director be, and hereby is, authorized to approve, within the Adequacy Determination for the Fan Pier Development Final Project Impact Report, that a lapse of time between the issuance thereof and the filing of a building permit application for the Fan Pier Development or any portion thereof which is consistent with a construction sequencing plan approved by the Director shall not be considered significant.

VOTED: That the Director be, and hereby is, authorized to submit to the Department of Environmental Protection of the Commonwealth of Massachusetts a so-called "Section 18" written recommendation stating that the Fan Pier Development will serve a proper public purpose and will not be detrimental to the public rights in tidelands.

VOTED: That the Director be, and hereby is, authorized to issue a Certification of Consistency pursuant to Section 80C-8 of the Code upon completion of the Article 80 review process, with such minor modifications as may arise from the more defined contract documents which result from BRA design review.

VOTED: That the Director be, and hereby is, authorized to issue a Certification of Compliance under Large Project Review pursuant to Section 80B-6 of the Code upon completion of the Article 80 review process, with such minor modifications as may arise from the more defined contract documents which result from BRA design review.

VOTED: That the Director be, and hereby is, authorized to execute and deliver all documents deemed appropriate by the Director in connection with the Fan Pier Development pursuant to Article 80, including, without limitation, a Cooperation Agreement, Development Impact Project Agreement, Boston Residents Construction Plan, First Source Agreement and Memorandum of Understanding, Transportation Access Plan Agreement and Construction Management Plan.

Map Amendment Application No. 457  
Planned Development Area No. 54, Fan Pier  
Map 4A, Harborpark District, Fort Point Waterfront  
and Dorchester Bay/Neponset River Waterfront

Boston Redevelopment Authority on behalf of Fan  
Pier Land Company

MAP AMENDMENT NO. 397

THE COMMONWEALTH OF MASSACHUSETTS

CITY OF BOSTON

IN ZONING COMMISSION

The Zoning Commission of the City of Boston, acting under Chapter 665 of the Acts of 1956, as amended, after due report, notice and hearing, does the following:

1. Approves the "Development Plan, Fan Pier Development, 28-52 Northern Avenue, Boston", dated November 14, 2001, and approved by the Boston Redevelopment Authority on November 14, 2001.

Said Development Plan fully and entirely supersedes "Master Plan and Development Impact Project Plan for Planned Development Area No. 23", approved by the Authority on February 12, 1986, and approved by the Zoning Commission on March 21, 1986, effective, March 27, 1986; and

2. Amends "Map 4A, Harborpark District: Fort Point Waterfront and Dorchester Bay/Neponset River Waterfront," of the series of maps entitled "Zoning Districts, City of Boston," dated August 15, 1962, as amended, by adding the designation "D", indicating a Planned Development Area overlay district, to approximately 909,799 square feet in area (20.9 acres), including 643,080 square feet of land (14.8 acres) and 266,719 square feet of water (6.1 acres), located at 28-52 Northern Avenue, Boston.

Said map amendment would fully and entirely supersede Map Amendment No. 190, adopted by the Zoning Commission on March 21, 1986, effective March 27, 1986.

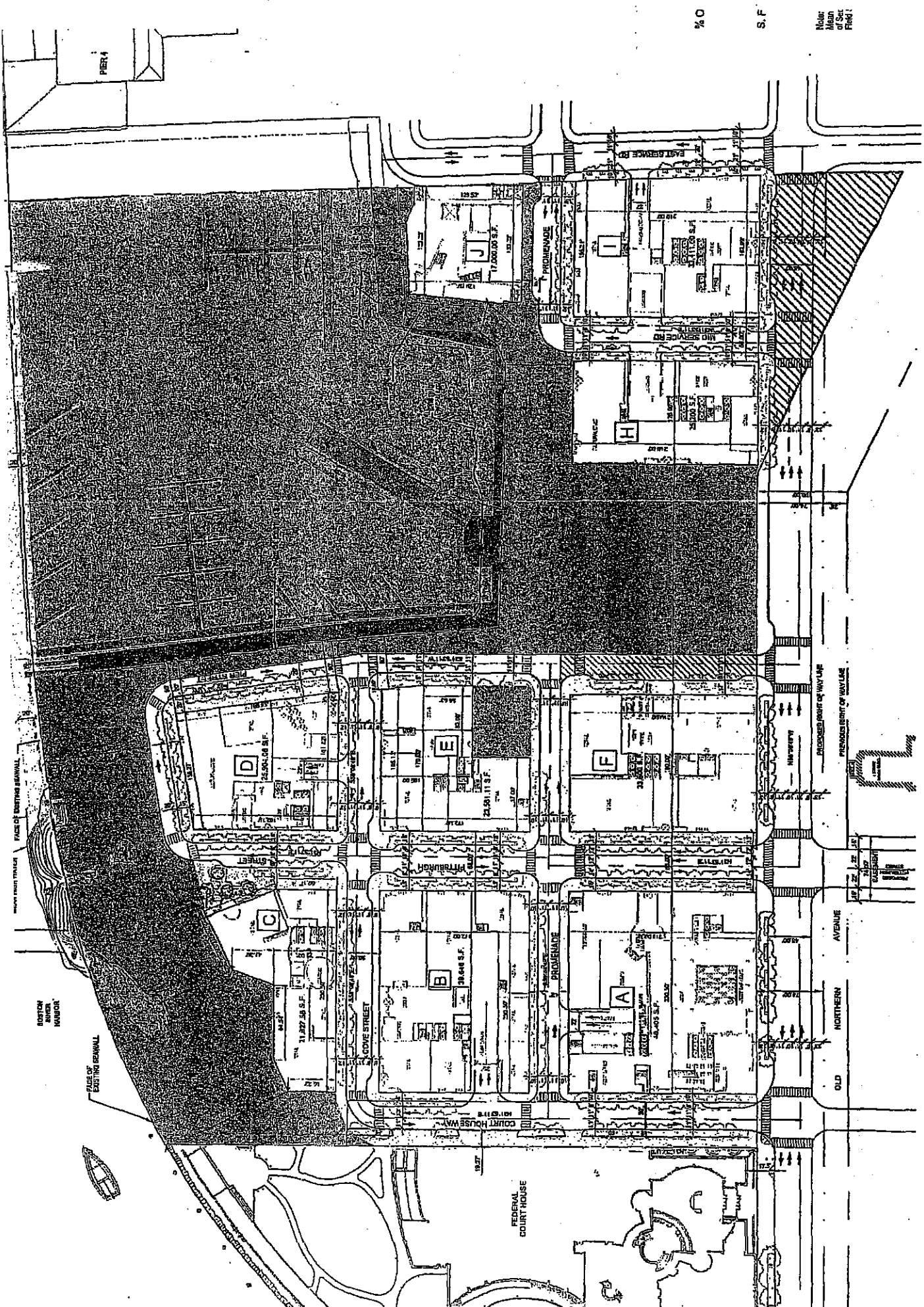

EXHIBIT A  
PROPERTY DESCRIPTION

Three certain parcels of land located on the northerly side of Northern Avenue in Boston, Suffolk County, Massachusetts, being shown as Lot 1B, Remainder of Lot A and Lot B on "Compiled Plan of Land in Boston, Massachusetts - South Boston District - Scale 1:960 - 7 December 1995" by Gunther Engineering, Inc. said lots being together bounded and described as follows:

Beginning at a point on the northerly sideline of Northern Avenue located 345.29 feet southeast of a stone bound situated on the northerly sideline of Northern Avenue, said point being the southwesterly corner of the parcel; thence running:

- ◆ NORTH 31° 53' 17"
- ◆ EAST 667.56 feet by Lot 1A on the Plan to a point; thence running
- ◆ NORTHEASTERLY 275.30 feet by a curve to the right having a radius of 910.00 feet to a point; thence continuing
- ◆ NORTHEASTERLY 400.00 feet by a curve to the right having a radius of 2370.00 feet to a point of tangency; thence turning and running
- ◆ SOUTH 61° 20' 09"
- ◆ EAST 440.11 feet, said last three courses being by the pier and bulkhead line of 1916 (abandoned); thence turning and running
- ◆ SOUTH 29° 46' 06"
- ◆ WEST 1,004.85 feet by land of now or formerly of Pier Four, Inc. to a point on the northerly sideline of Northern Avenue; thence turning and running
- ◆ NORTH 34° 06' 20"
- ◆ WEST 381.13 feet by said Northern Avenue to a point on the northerly sideline of Northern Avenue; thence turning and running
- ◆ NORTH 58° 06' 43"
- ◆ WEST 779.05 feet by Northern Avenue to the point of beginning.
- ◆ Containing 20.887 acres, more or less, according to the Plan.



% O S. F. Note: Mean of Sec. Field 1

# Fan Pier Development

60 0 60 120 Feet

Map Amendment Application No. 457

Map Amendment No.

Chairman

Robert Foudreaux

Vice Chairman

Paul Lopez

Marie P. Loring  
Marie A. Lopez

Jim Statten

Jay Buckley  
Jim Gray Brayton  
William Taylor

In Zoning Commission

Adopted: February 27, 2002

Attest:

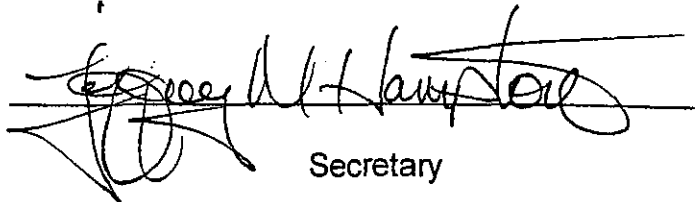

Secretary

Development Plan for Planned Development Area No. 54, Fan Pier

Chairman

Robert Jordan

Vice Chairman

William Toulon

Jane Anne Brayton

Jay Hurley

Jill Stathou

Deanne Adams

Mary P. King

[Signature]

[Signature]

In Zoning Commission

Adopted: February 27, 2002

Attest:

[Signature]

Secretary

Map Amendment Application No. 457

Map Amendment No. 397

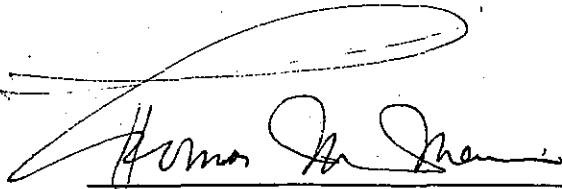

\_\_\_\_\_  
Mayor, City of Boston

Date: 3/2/02

\_\_\_\_\_  
The foregoing amendment was presented to the Mayor on FEBRUARY 28, 2002, and was signed by him on MARCH 1, 2002, whereupon it became effective on MARCH 1, 2002, in accordance with Section 3 of Chapter 665 of the Acts of 1956, as amended.

Attest:

  
\_\_\_\_\_  
Secretary to the Zoning Commission

Development Plan, Fan Pier Development, 28-52 Northern Avenue, Boston

  
\_\_\_\_\_  
Mayor, City of Boston

Date: 3/7/02

---

The foregoing Development Plan was presented to the Mayor on ~~FEBRUARY 28, 2002~~  
and was signed by him on ~~MARCH 1, 2002~~, whereupon it became effective on  
~~MARCH 1, 2002~~, in accordance with Section 3 of Chapter 665 of the Acts of 1956,  
as amended.

Attest:   
\_\_\_\_\_  
Secretary to the Zoning Commission